



GOVERNMENT OF TAMIL NADU

HIGHER SECONDARY SECOND YEAR

VOCATIONAL EDUCATION

Basic Mechanical Engineering

THEORY & PRACTICAL

A publication under Free Textbook Programme of Government of Tamil Nadu

Department of School Education

Untouchability is Inhuman and a Crime

Government of Tamil Nadu

First Edition - 2019

Revised Edition - 2022

(Published under New Syllabus)

NOT FOR SALE

Content Creation



State Council of Educational
Research and Training

© SCERT 2019

Printing & Publishing



Tamil Nadu Textbook and
Educational Services Corporation

www.textbooksonline.tn.nic.in

PREFACE

This book “**Basic Mechanical Engineering**” has been written entirely based on new syllabus framed by TNSCERT. The subject matter is explained in a simple manner and simple language, lightened by sufficient colourful diagrams, illustrations with learning objectives.

In each chapter, Quotes, Activities, “Do you Know” and web search link have been given to enhance the student knowledge. QR Codes, ICT Corner for the tough area of the subject are marked which helps the students to understand the subject further in detail and quickly. Line diagrams as well as 3-Dimension views are given for easy understanding. Model Question has also been included at the end of the last chapter. Case studies are included at the end of this book which focus the importance of this **Basic Mechanical Engineering** course and also motivate the students to join and learn in the Engineering fields.

We sincerely convey my thanks to the Director, Joint Director and Staff members whose patronage on this book to come out successfully and the committee of experienced Teachers who beard the responsibility of the book to come out in good shape.

In spite of all our efforts, some errors and mistakes might have crept in. Any error or misprint, if pointed out and any suggestion for the improvement of the book will be thankfully acknowledged.



Learning Objectives

Learning objectives briefly describe the contents of the unit. It also outlines the knowledge gained by the students.



Interesting facts to motivate students to gain more information regarding the unit.

Infographics

Visual representations of the unit for better understanding.

Concept Figures

Conceptual diagrams that potrays the technique of drafting and sewing.

**HOW TO USE
THE BOOK**



To facilitate reading at anytime, anywhere.

Activity

Skill oriented activities based on the units for better understanding.

Evaluation

Access students under the category of understanding, reproducing and application oriented.

Model Question Paper

A model question paper to help students to face examinations.

References

List of related books for further reading.

Case Study

Brief note on successful students who have pioneers in the field.

Career Guidance

List of job opportunities on successful completion of course

CAREER GUIDANCE

AFTER COMPLETION OF 12TH VOCATIONAL GROUP

Basic Mechanical Engineering

Higher Education (Vertical Mobility)

1. Directly to Join 2nd year Diploma Engineering in Government and Government Aided and private polytechnics.
2. 10% of the Seats are allotted to Government and Government Aided and Private Engineering colleges to join first year Bachelor of Engineering (B.E).
3. To Distance Education Directly undergo the course AMIE which is equal to Government Engineering Courses.

Arts Group Area

1. +2 Vocational Groups Students are eligible to Join Ist year Diploma Teacher Training Course.
2. Directly Join B.A. Arts Group Except – Physics, Chemistry, Biology major all other Science group.
3. Directly Join B.Sc-Maths Group and B.Sc-Computer Science.

Horizontal Mobility

Employments

1. Directly Join to Reputed Industries as Apprentice Training/Factory Training like
 - a) Ashok Leyland (Chennai and Hosur)
 - b) TVS Groups (Chennai, Hosur, Madurai, etc.)
 - c) Simpson Engineering Groups (Chennai, Hosur, Redhills, etc.)
 - d) Hyundai Car Company (Sriperumbudur, Irrungattukotttai, Chennai)
 - e) Ford India Ltd. (Maraimalai Nagar, Kanchipuram Dt.)
 - f) All Reputed Service centers like TVS, VST and Hyundai, Ford etc.
 - g) All Automobile leading manufacturing, repairing and servicing centers.

Self-Employment

1. Vocational Students after getting Apprentice Training Industry Training are eligible to get small scale Industry Loan from Hudco, TIDCO, SIDCO etc.
2. After getting required experience in the field, they are eligible to get minimum loans under the scheme of
 - a) NRY (Nehru Rozhar Yogana)
 - b) PMRY (Prime Minister Rozhar Yogana)
 - c) TRYSEM (Training for Rural Youth and Self Employment)
 - d) PMKVY (Pradhan Mantri Kaushal Vikas Yojana)

CONTENTS

S.No	CHAPTER TITLE	PAGE NO.	PERIOD	MONTH
01	Lathe	1-30	28	June
02	Drilling Machine	31-56	14	July
03	Shaping Machine	57-76	14	July
04	Grinding Machine	77-98	28	August
05	Milling Machine	99-118	14	September
06	Machine Tool Maintenance	119-126	10	October
07	Welding	127-140	18	October
08	Hydraulic Equipments	141-154	14	November
09	CNC Machines	155-164	14	November
10	Automation and Robotics	165-176	14	December



E-book



Assessment

TABLE OF CONTENTS

CHAPTER 01 Lathe 01

- 1.1 Introduction
- 1.2 Turning
- 1.3 Structure of a lathe
- 1.4 Main parts of a lathe
- 1.5 Feed mechanisms
- 1.6 Tumbler gear
- 1.7 Apron
- 1.8 Spindle Mechanism
- 1.9 Stepped cone pulley mechanism
- 1.10 Back gear mechanism
- 1.11 Gear box mechanism
- 1.12 Types of lathe
- 1.13 Differences between capstan and turret lathe
- 1.14 Specification of lathe
- 1.15 Work holding devices used in a lathe
- 1.16 Cutting speed, feed and depth of cut in lathe
- 1.17 Tools used in a lathe
- 1.18 Operations performed in a lathe
- 1.19 Taper turning
- 1.20 Thread cutting

Chapter 02 Drilling Machine 31

- 2.1 Introduction
- 2.2 Drilling Method
- 2.3 Construction of a drilling machine

- 2.4 Types of drilling machines
- 2.5 Portable drilling machine
- 2.6 Sensitive drilling machine
- 2.7 Up-right drilling machine
- 2.8 Radial drilling machine and its special features.
- 2.9 Gang drilling machine
- 2.10 Multi – spindle drilling machine
- 2.11 Deep – hole drilling machine
- 2.12 Size of a drilling machine
- 2.13 Drill spindle assembly
- 2.14 Work – holding devices.
- 2.15 Tools used in a drilling machine
- 2.16 Twist – drill nomenclature
- 2.17 Tool – holding devices
- 2.18 Drilling machine operations
- 2.19 Cutting speed. Feed and depth of cut
- 2.20 Safety precautions

Chapter 03 Shaping Machine 57

- 3.1 Introduction
- 3.2 Process of machining
- 3.3 Main parts of the shaping machine
- 3.4 Types of shaping machine
- 3.5 Quick return mechanism
- 3.6 The size of a shaper
- 3.7 Adjusting the length of stroke
- 3.8 Method of table movement
- 3.9 Pawl and Ratchet mechanism
- 3.10 Swivel tool head
- 3.11 Work-Holding devices
- 3.12 Types of shaper tools
- 3.13 Setting of shaper table, vice and Tool head
- 3.14 Types of shaping operations
- 3.15 Special operations

- 3.16 Cutting speed, depth of cut and feed
- 3.17 Coolant
- 3.18 Safety precautions

Chapter 04 Grinding Machine 77

- 4.1 Introduction
- 4.2 Types of grinding machine
- 4.3 Non-precision grinding machine
- 4.4 Precision grinding machine
- 4.5 Size of grinding machine
- 4.6 Centreless grinding
- 4.7 Grinding operations
- 4.8 Wet and Dry grinding
- 4.9 Grinding wheel
- 4.10 Abrasive
- 4.11 Grinding wheel specification
- 4.12 Mounting grinding wheel
- 4.13 Glazing, loading and chattering
- 4.14 Balancing of grinding wheel
- 4.15 Cutting speed, Feed and Depth of cut
- 4.16 Precision operations
- 4.17 Safety precautions

Chapter 05 Milling Machine 99

- 5.1 Introduction of milling machine
- 5.2 Horizontal milling machine
- 5.3 Vertical milling machine
- 5.4 Types of milling machine
- 5.5 Differences between plain milling machine and universal milling machine
- 5.6 Size of milling machine
- 5.7 Fundamental of milling
- 5.8 Work – holding devices
- 5.9 Cutter holding devices
- 5.10 Milling machine attachments

- 5.11 Isomeric view of milling cutters
- 5.12 Standard milling cutters
- 5.13 Elements of plain milling cutter
- 5.14 Milling cutter materials
- 5.15 Milling machine operations
- 5.16 Cutting speed, feed and depth of cut
- 5.17 Indexing head
- 5.18 Construction of indexing head
- 5.19 Indexing methods
- 5.20 Safety precautions

Chapter 06 Machine Tool Maintenance 119

- 6.1 Introduction
- 6.2 Purpose of Maintenance
- 6.3 Tear and wear
- 6.4 Backlash
- 6.5 Lubrication
- 6.6 Important machine parts for lubrication
- 6.7 Purpose of lubrication
- 6.8 Types of lubricant
- 6.9 Types of lubrication
- 6.10 Central maintenance department
- 6.11 Types of maintenance
- 6.12 Routine maintenance
- 6.13 Daily maintenance
- 6.14 Weekly maintenance
- 6.15 Preventive maintenance
- 6.16 Breakdown maintenance
- 6.17 Capital repairs
- 6.18 Planned maintenance program
- 6.19 Instruments needed for maintenance

Chapter 07 Welding..... 127

- 7.1 Introduction
- 7.2 Types of welding
- 7.3 Classification of welding process
- 7.4 Arc. Welding
- 7.5 Arc welding equipments
- 7.6 Difference between D.C. welding generator, and AC welding Transformer.
- 7.7 Specification of Electrodes.
- 7.8 Types of Electrodes.
- 7.9 Selection of electrodes.
- 7.10 Carbon Arc welding
- 7.11 Gas welding
- 7.12 Types of welding
- 7.13 Filler rods used in gas welding
- 7.14 Advantages of Gas welding
- 7.15 Disadvantages of Gas welding
- 7.16 Difference between Arc welding and Gas welding
- 7.17 Resistance welding
- 7.18 Welding Related processes.
- 7.19 Types of welding joint
- 7.20 Safety precautions for welding.

Chapter 08 Hydraulic Equipments 141

- 8.1 Introduction
- 8.2 Hydraulic pumps
- 8.3 Properties of positive displacement pump
- 8.4 Properties of Non-positive displacement pump.
- 8.5 Types of centrifugal pump
- 8.6 Types of Reciprocating pump
- 8.7 Types of Rotary pump
- 8.8 Centrifugal pump
- 8.9 Reciprocating pump
- 8.10 Difference between centrifugal and a reciprocating pump

- 8.11 Rotary pump
- 8.12 Hydraulic motor
- 8.13 Hydraulic cylinder
- 8.14 Hydraulic valve
- 8.15 Hydraulic circuit for shaping machine
- 8.16 Advantages of hydraulic drive over mechanical drive

Chapter 09 CNC Machines 155

- 9.1 Introduction
- 9.2 Numerical control
- 9.3 Computer Numerical control
- 9.4 Elements of CNC machines.
- 9.5 Software
- 9.6 Input Media
- 9.7 Machine control unit
 - a. Inbuilt MCU
 - b. Swivel MCU
 - c. stand alone MCU
- 9.8 Driving devices
- 9.9 Machine tool.
- 9.10 Classification of CNC machine tools.
- 9.11 Advantages of CNC machines over conventional machine tools.
- 9.12 Programming for CNC machines.
- 9.13 Advancements in NC machines.

Chapter 10 Automation and Robotics 165

- 10.1 Introduction of Automation
- 10.2 Types of Automation
- 10.3 Need for industrial Automation
- 10.4 The advantages of Automation
- 10.5 Applications of Automation
- 10.6 Elements of Automation
- 10.7 Introduction of Robotics
- 10.8 Definition of Robotics

- 10.9 Objectives of industrial Robotics
- 10.10 Advantages
- 10.11 Three main components of Robots
- 10.12 Asimov Laws of Robotics
- 10.13 Need of Robotics
- 10.14 Types of Robots
- 10.15 Applications of Robotics
- 10.16 Parts of Robots
- 10.17 Materials used for Robots

Basic Mechanical Engineering

THEORY

Lathe



Learning Objectives

- Students to learn about the construction of Lathe and its parts, structure and its operation.
- To understand the feed mechanism of tumbler gear and apron in lathe.
- To know about the types of lathe and its details, difference between capstan and turret lathe and work holding devices in lathe.
- To understand the cutting speed, feed and depth of cut in a lathe, various types of operation and taper turning methods and thread cutting operation.



"Panivudaiyan insolan aadhal oruvarku
Aniyalla matru pira".

–Kural 95

Humility with pleasant speech to man on earth, Is choice
adornment, all besides is nothing worth.

CONTENTS

- | | |
|-----------------------------------|--|
| 1.1 Introduction | 1.12 Types of lathe |
| 1.2 Turning | 1.13 Differences between capstan and turret lathe |
| 1.3 Structure of a lathe | 1.14 Specification of lathe |
| 1.4 Main parts of a lathe | 1.15 Work holding devices used in a lathe |
| 1.5 Feed mechanisms | 1.16 Cutting speed, feed and depth of cut in lathe |
| 1.6 Tumbler gear | 1.17 Tools used in a lathe |
| 1.7 Apron | 1.18 Operations performed in a lathe |
| 1.8 Spindle Mechanism | 1.19 Taper turning |
| 1.9 Stepped cone pulley mechanism | 1.20 Thread cutting |
| 1.10 Back gear mechanism | |
| 1.11 Gear box mechanism | |



The inventor of Lathe is Henry Maudslay, in the year 1797. He is also called as father of Machine Tools.



1.1 Introduction

Lathe is considered as one of the oldest machine tools and is widely used in industries. It is called as mother of machine tools. The first screw cutting lathe was developed by an Englishman named “Henry Maudslay” in the year 1797. Modern high speed, heavy duty lathes are developed based on this machine.

1.2 Turning

The primary task of a lathe is to generate cylindrical workpieces. The process of machining a workpiece to the required shape and size by moving the cutting tool either parallel or perpendicular to the axis of rotation of the workpiece is known as turning.

In this process, excess unwanted metal is removed. The machine tool useful in performing plain turning, taper turning, thread cutting, chamfering and knurling by adopting the above method is known as lathe.

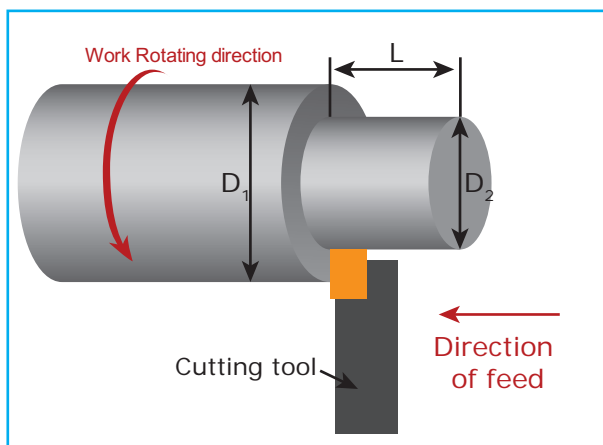

Turning

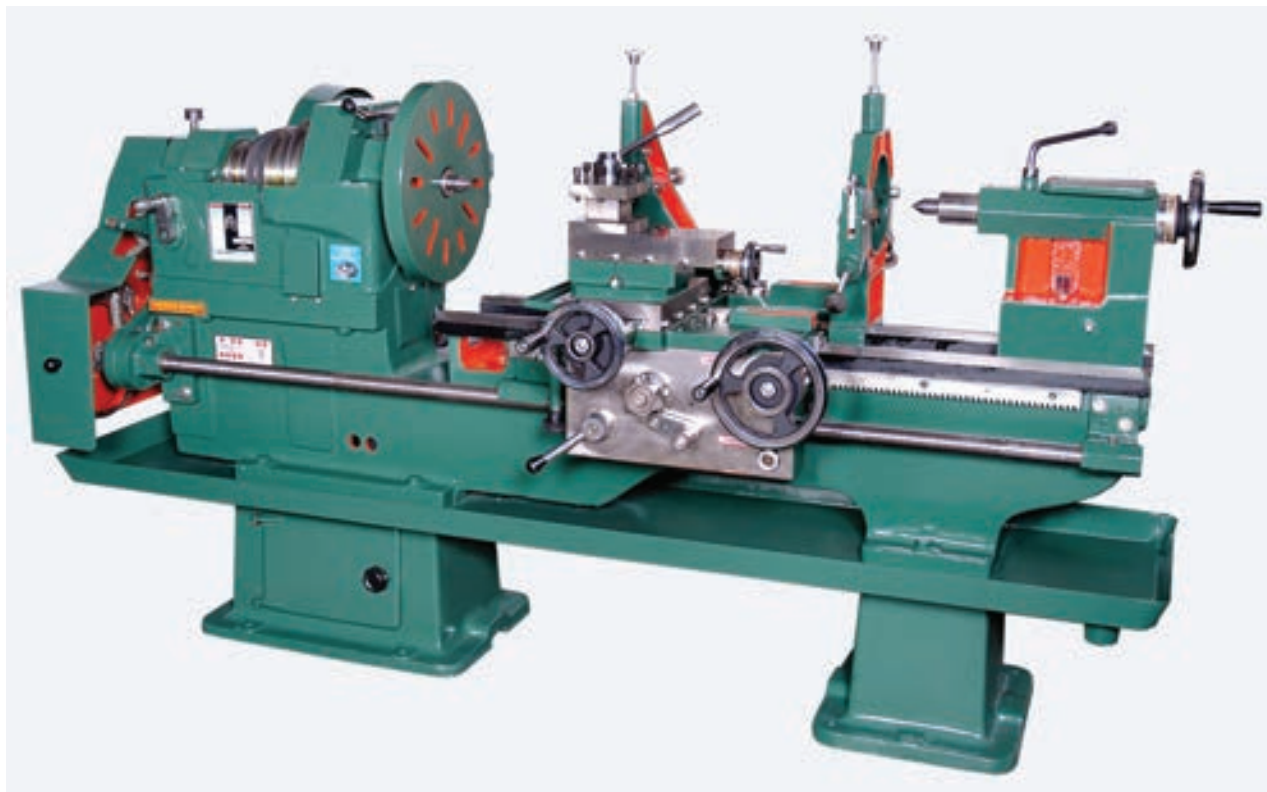

View of Lathe

1.3 Structure of Lathe

The lathe has bed on which head stock is mounted on left end, tailstock at right end and carriage is placed and moved on the bed.

1.4 Main parts of a lathe

Every individual part performs an important task in a lathe. Some important parts of a lathe are listed below.

1. Bed
2. Headstock
3. Spindle
4. Tailstock
5. Carriage
 - a. Saddle
 - b. Cross – slide



- c. Compound rest
 - d. Compound slide
 - e. Tool post
 - f. Apron
6. Leadscrew
 7. Feed rod

Bed

Bed is mounted on the legs of the lathe which are bolted to the floor. It forms the base of the machine. It is made of cast iron and its top surface is machined accurately and precisely. Headstock of the lathe is located at the extreme left of the bed and the tailstock at the right extreme. Carriage is placed in between the headstock and tailstock moves on the bed guide ways.

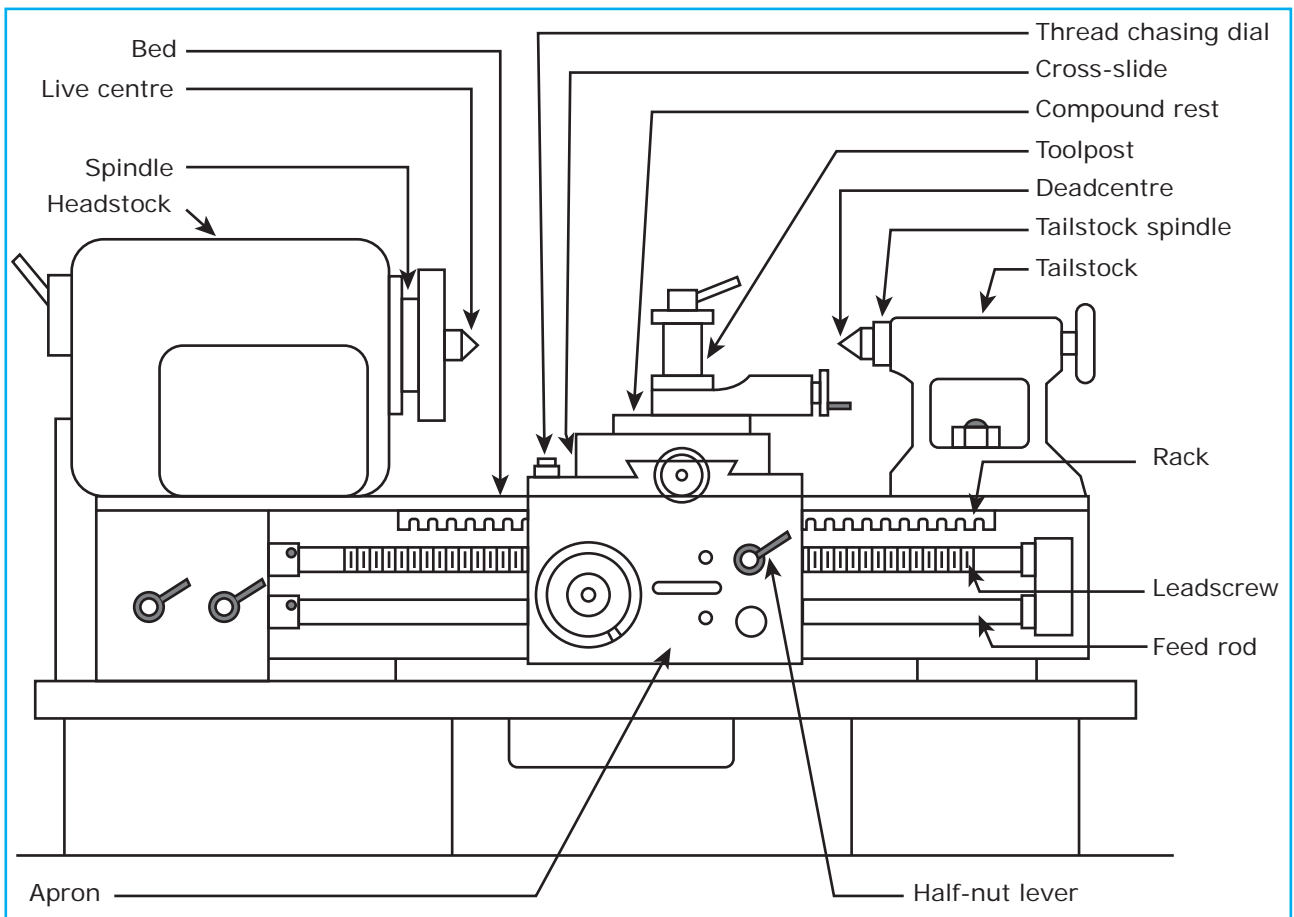

Lathe

The top of the bed has a guideways which is manufactured in two shapes

1. Flat shaped
2. V - Shaped



Flat shaped



V - Shaped

The tailstock and the carriage slides on these guideways. Flat bed guide ways can be found in older machine tools. It is useful in heavy duty machines, handling large workpieces. Though, it is less accuracy. V-type bed have been found in modern machine tools. This type of V-bed gives accurate alignment to carriage and tailstock. The metal chips automatically fall through.

Headstock

Headstock is mounted permanently on the inner guideways at the left hand side of the lathe bed. The headstock houses a hollow spindle and the mechanism for driving the spindle at multiple speeds. The headstock will have any of the following arrangements for driving and altering the spindle speeds.



Headstock

1. Stepped cone pulley mechanism
2. Back gear mechanism
3. Gear box mechanism

Spindle

The spindle freely rotates on two large bearings housed on the headstock casting. It is made of carbon or nickel chrome steel. A hole extends through the spindle so that a long bar stock may be passed through the hold. The front end of the spindle is threaded on which any one of the work holding devices can be screwed. The front end of the hole is tapered to receive live centre which supports the work. On the other side of the spindle, a gear known as a spindle gear is fitted. Through this gear, tumbler gears and a main gear train, the power is transmitted to the gear on the lead screw.

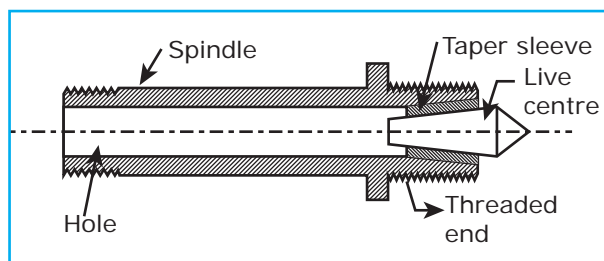

Spindle

Tailstock

Tailstock is located on the inner guideways at the right side of the lathe bed. The body of the tailstock is bored and houses the tailstock spindle. The spindle moves front and back inside the hole. The spindle has a taper hole to receive the dead centre or shanks of tool like drill or reamer. If the tailstock hand wheel is rotated in clockwise direction, the spindle advances. The spindle will be reversed inside the hold, if the handwheel is rotated in anti-clockwise direction.

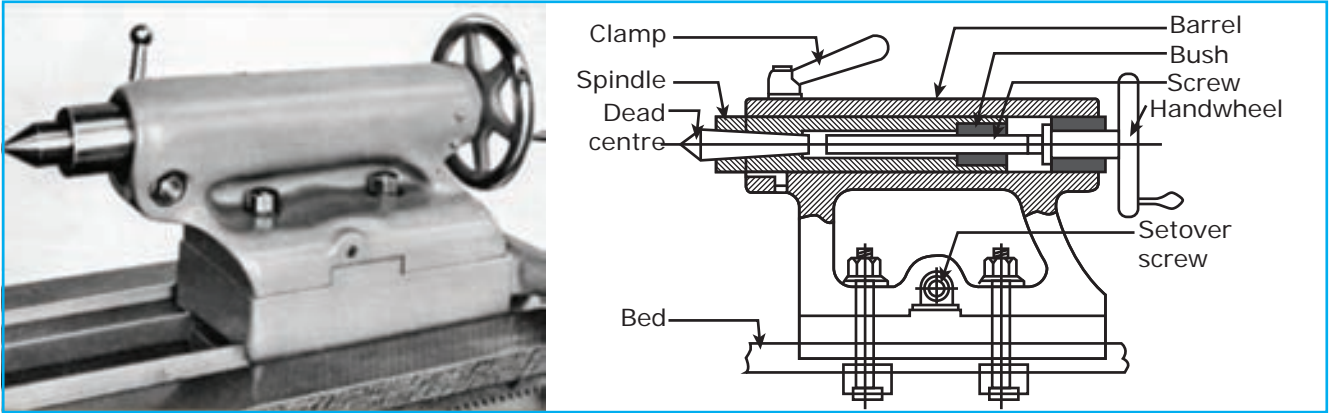

Tailstock

To remove the dead centre or any other tool from the spindle, the handwheel is rotated in anticlockwise direction further. The movement of the spindle may be locked by spindle clamp, located on top of the tailstock. To hold different lengths of work, the tailstock can be adjusted and locked at desired position on the lathe bed. The casting of the tailstock body is divided into two. The lower casting of the body can be clamped to the bed. The upper casting can be moved sideways from lathe axis.

Uses of Tailstock

1. It supports the right end of the long workpiece when it is machined between centres.

2. It is useful in holding tools like drills, reamers and taps when performing drilling, reaming and tapping.
3. The upper casting of the body is set off by a small distance from the axis of the lathe to turn tapers on the work pieces.
4. It is useful in setting the cutting tool at correct height aligning the cutting edge with lathe axis.

Carriage

Carriage is located between the headstock and tailstock on the lathe bed guideways. It can be moved along the bed either towards or away from the headstock. It has several parts to support, move and control the cutting tool.

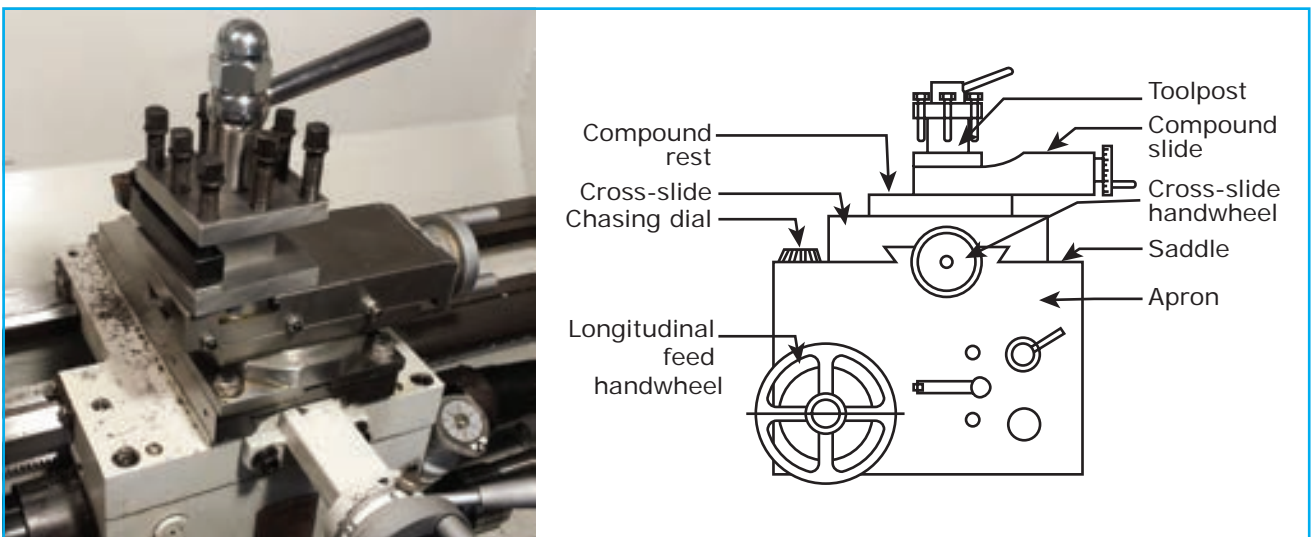

3D- View of Carriage

Carriage

The parts of the carriage are

- a. Saddle
- b. Cross slide
- c. Compound rest
- d. Compound slide
- e. Tool post
- f. Apron

Saddle

Saddle connects the front and back portion of bed guideways like a bridge. It is an 'H' shaped casting. It moves along the bed between headstock and tailstock. The saddle can be moved by providing hand feed or automatic feed.

Cross slide

Cross slide is situated on the saddle and slides on the dovetail guideways at right angles to the bed guideways. It carries compound rest, compound slide and tool post. The cross slide can be moved at right angles to the lathe axis by giving hand feed or automatic feed.

Compound rest

Compound rest is a part which connects cross slide and compound slide. It is mounted on the top of the cross slide by tongue and groove joint. It has a circular base on which angular graduations are marked. The compound rest can be swiveled to the required angle while turning tapers. A top slide known as compound slide is attached to the compound rest by dove tail joint. The tool post is fixed on the compound slide.

Tool post

The tool post is mounted on the compound slide. It is used for holding the cutting tool tightly. According to the

operations on the work piece, tool may be changed and fixed on the tool post. There are different types of tool post. In which,

1. Single screw tool post
2. Four way tool post are widely used.

Single screw tool post

One tool can be held by the single screw tool post. The tool is clamped by one clamping screw. A concave ring is found in the tool post. A convex rocker iron piece has got a convex surface at its bottom and flat surface at its top. This rocker iron piece is placed on the concave ring. The tool rests on the top flat surface of the rocker.

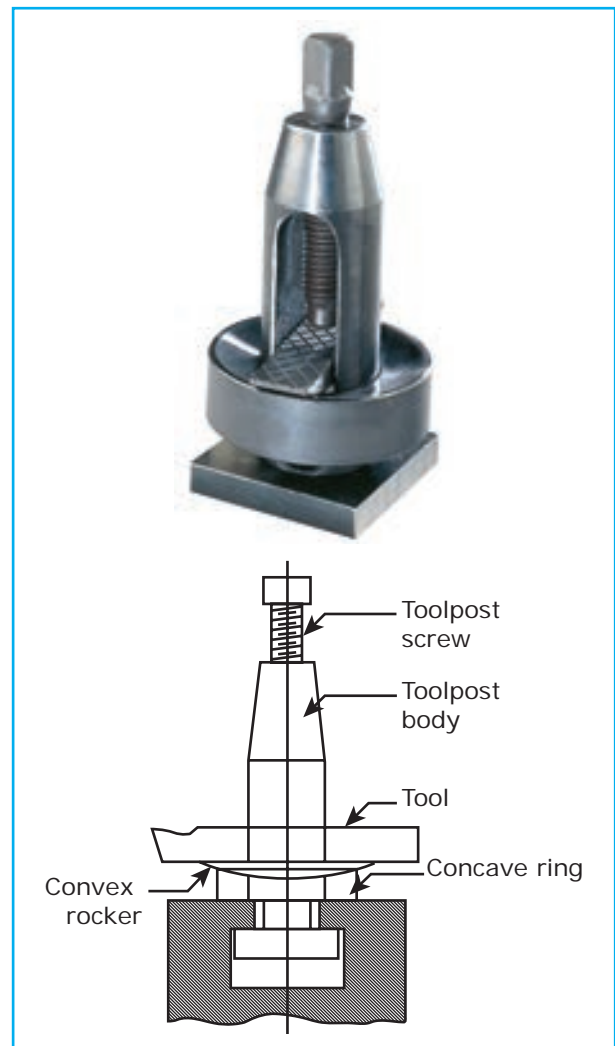

Single screw tool post

The height of the tool point can be adjusted by moving the rocker front and back. As the tool is clamped by only one clamping screw, it is not preferable for heavy duty works.

Four way tool post

Four way tool post is known as Turret tool post. Four different types of tool can be placed and clamped at a time. The required tool can be turned towards the workpiece for turning process. As the required tools fitted ready in position, the turning work is easier and faster. This type of tool post is used in heavy duty lathes.

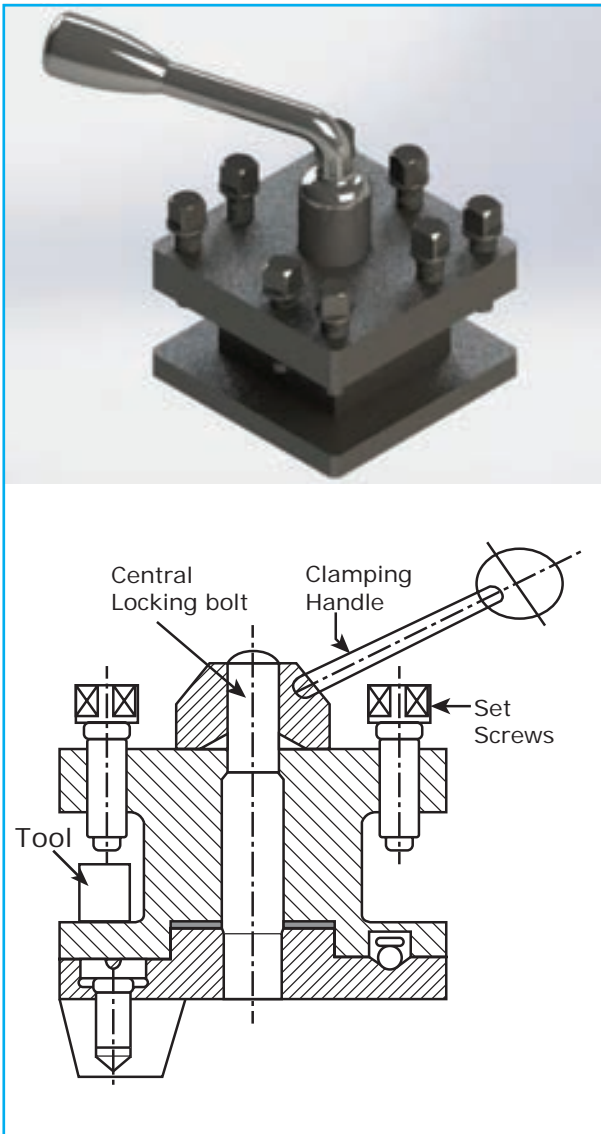

Four way tool post

1.5 Feed Mechanism

By using various feed mechanism, the rotation of leadscrew and feed rod direction can be changed and so the direction of carriage and cross slide movements can also be changed.

There are so many feed mechanisms used in lathe, among them the important mechanisms are discussed below.

1.6 Tumbler Gear

A set of two small gears are placed just below the spindle gear and connected to the spindle gear in the lathe. The set of gears is known as tumbler gear.

The set of two small tumbler gears are fitted in a bracket. The bracket position can be adjusted into three positions such as neutral, upwards and downwards. By adjusting the position of tumbler gear, the rotation of leadscrew and feed rods direction can be changed.

Neutral Position

In this position, the tumbler gears lever is in the middle position hence, the tumbler gears are not engaged with spindle gear and the intermediate gears and so, automatic feed is not received.

Forward position

In this position, the tumbler gears lever is shifted upward position. Here only one tumbler gear is in contact with the spindle gear, hence, the leadscrew rotates in the same direction of the spindle rotation. The carriage moves towards headstock.

Reverse Position

In this position, the tumbler gears lever is pushed downward position. Here

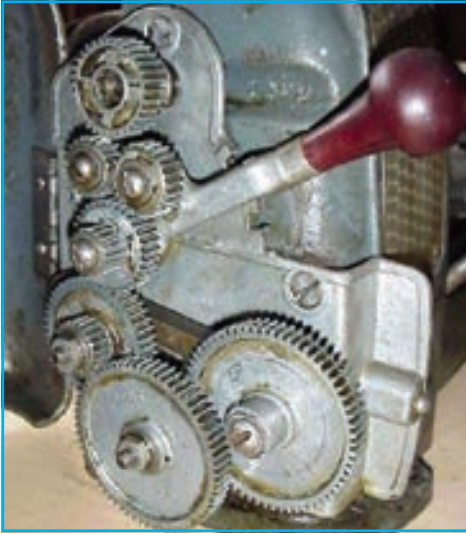

3D- Tumbler Gear

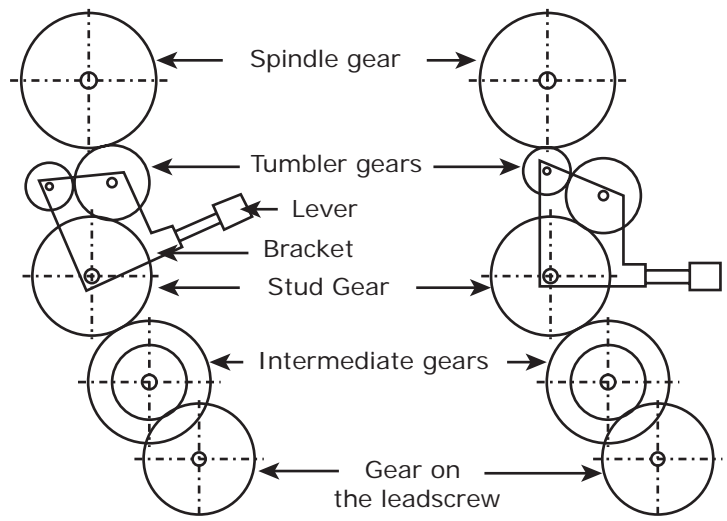

Tumbler Gear

leadscrew and feed rod receive rotational movement from spindle gear through tumbler gears. Hence, they rotate in opposite direction of the spindle rotation. So the carriage will move towards tailstock.

1.7 Apron Mechanism

Apron is attached to the carriage and hangs over the front side of the lathe bed. It is useful in providing power and hand feed to both carriage and cross-slide. It is also used to provide power feed to the carriage during thread cutting through two half nuts.

The gear attached to the spindle is called spindle gear. Feed rod (A) and lead screw (B) receives rotational movement from spindle gear through the tumbler gear. Worm (W) and worm gear (WG) mechanism is fixed in worm gear rod (A). One more gear (G) is fixed in worm gear shaft. Gear G_1 and G_2 is connected as shown in the figure. Gear G_4 is inserted in the rack gear. Gear G_3 is mounted on Gear G_4 axis. Handle (H) for longitudinal feed and gear G_5 are mounted on the same axis. Gears G_3 and G_5 are always connected each other.

There is a feed check lever (F), which can be adjusted into three positions

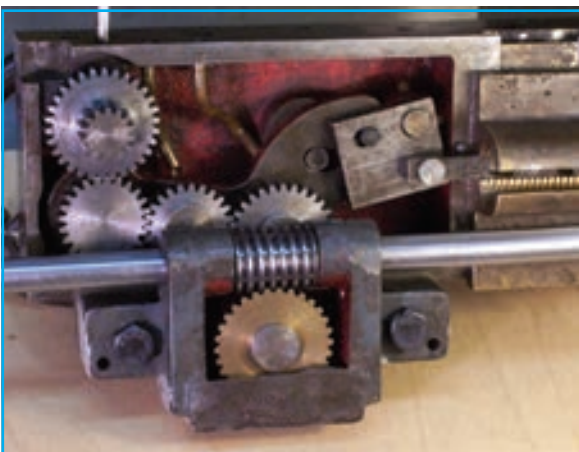

3D-Apron

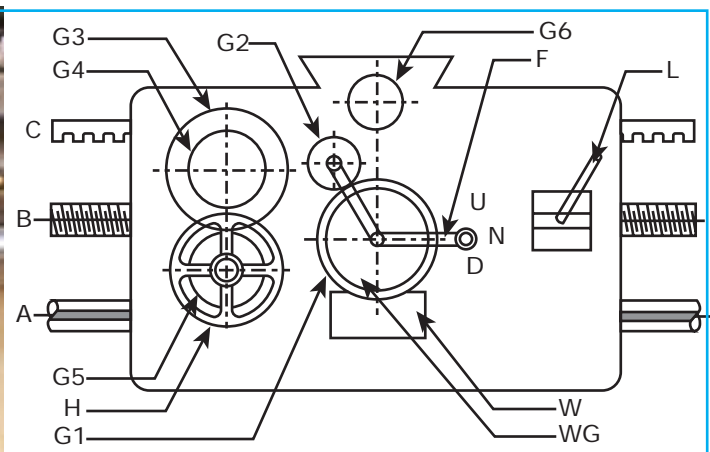

Apron

such as neutral, upwards and downwards so, the following movements can be obtained.

Hand feed to the carriage

Keep the feed check lever (F) in neutral position and if cross feed wheel is rotated by hand, the cross slide moves towards the lathe axis.

Automatic feed to the cross slide

When feed check lever is kept in downward (D), gear G2 will be connected to G6. The rotation of G6 will make the cross slide to move automatically.

Automatic feed to the carriage for thread cutting

When the two half nuts in the apron are connected to the leadscrew by using lever (L), leadscrew makes the carriage to move automatically and cut threads for required pitch value.

Lead screw

The lead screw is a long threaded shaft. It is used for moving the carriage automatically to a calculated distance only when threads have to be cut. Mostly leadscrews have an Acme thread.

The leadscrew is held between two bearing in front of the lathe bed. A gear is attached to the leadscrew at left end. The gear is called as gear on leadscrews. A half nuts lever is provided in the apron to engage the halfnuts with the leadscrew.

If the half nuts are engaged with the running screw the carriage will move automatically. When the lead screw is kept stationary the carriage is locked at the required position by using half nuts.

Feed Rod

Feed rod is placed parallel to the leadscrew in front side of the bed. It is a plain long shaft which has a keyway along its length. The power is transmitted from the spindle to the feed rod through tumbler gears and a gear train. It is useful for providing feed movement to the carriage and cross slide, except thread cutting time.

1.8 Spindle Mechanism

The spindle is located in the headstock and it receives the driving power from the motor. The spindle speed should be changed to suit different machining conditions like type of material to be cut, the diameter and the length of the work, type of operation, the type of cutting tool material used, the type of finish desired and the capacity of the machine. In order to change the spindle speeds, any one of the following methods are employed.

1. Stepped cone pulley mechanism
2. Back gear mechanism
3. Gear box mechanism

1.9 Stepped Cone Pulley Mechanism

It is simple in construction. A stepped cone pulley is attached with the spindle contained within the headstock casting. The cone pulley has four steps (A, B, C & D). Another cone pulley having four steps (E, F, G and H) is placed parallel to the spindle cone pulley. Both the cone pulleys are connected by a flat belt. The belt can be arranged between the steps A & H, B & G, C & F and D & E. The cone pulley at the bottom is connected to the electric motor by a 'V' – belt. So the cone pulley at the bottom rotates at a particular speed.

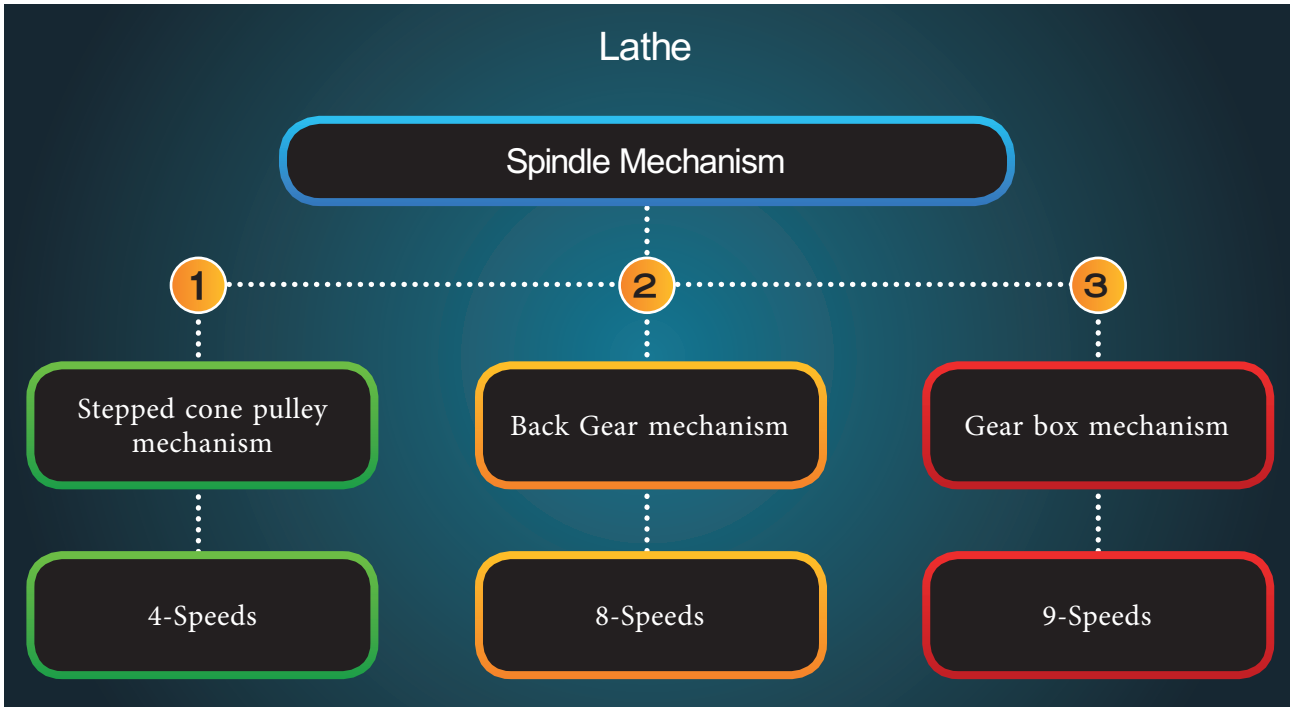

The belt is arranged on any one of the four steps to obtain different spindle speeds. If the belt is placed on the smaller step of the driven pulley, the spindle speed will be increased. For example, when the belt is arranged between A & H the spindle speed will be maximum.

When it is between D & E, the speed will be minimum. Stepped cone pulley drive is illustrated in figure.

1.10 Back gear mechanism

Back gear mechanism is housed within the headstock of the lathe. A step cone pulley having steps ABCD and a small pinion 'P' are mounted on the spindle and rotates freely on it. The gear 'S' is keyed to the head stock spindle. So the spindle will rotate only when the gear 's' rotates.

The step cone pulley ABCD and the gear 'S' can be kept separately or made as one unit with the help of a pin 'T' when the pin is disengaged, the cone pulley along with the gear P will rotates freely on the spindle and the spindle will not rotate. There is another shaft parallel to the spindle axis having back gear Q and R mounted on it. These back gears can be made to mesh with gears 'P' and 'S' or kept disengaged from them. The spindle can get drive either from the cone pulley or through back gears.

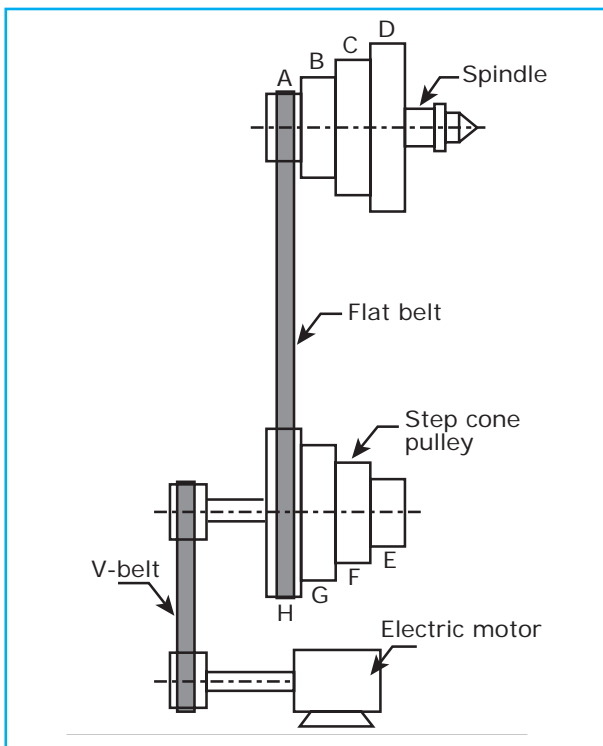



3D- Back gear mechanism

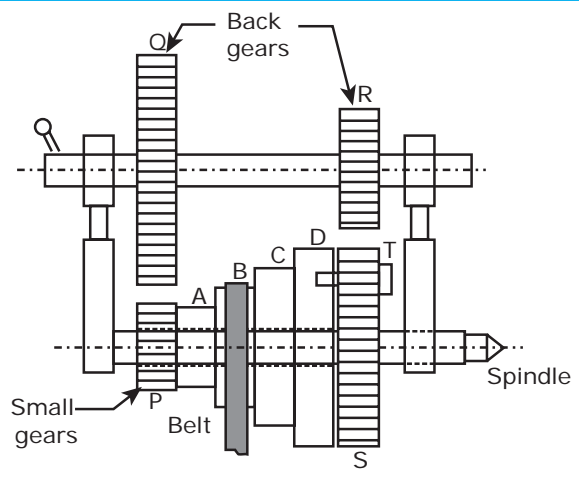

Back gear mechanism

Drive from step cone pulley

When the spindle gets drive from the cone pulley, the back gears Q and R are disengaged from the gears P and S. The pin 'T' is engaged with cone pulley.

The belt can be arranged on the steps ABC or D to get four different direct speeds for the spindle.



Drive through back gears

Back gears Q and R are engaged with gears P and S. The pin 'T' is disengaged from the cone pulley to make the cone pulley and the spindle separate units. When the cone pulley gets drive through the belt, the power is transmitted through the gears P, Q and R to the gear S, because of number of teeth on these gears, the spindle rotates at slower speeds. By arranging the belt on the different steps of the cone pulley, four different spindle speeds are obtained.

Uses of back gear arrangement

1. It is used for reducing the spindle speed, when turning on larger diameter of the work pieces and cutting coarse threads.
2. Eight different types of spindle speed can be obtained by this mechanism.

1.11 Gear Box Mechanism

Modern lathes are equipped with all geared headstocks to obtain different spindle speeds quickly. Casting of the all geared headstock has three shafts (1, 2 & 3) mounted within it. The intermediate shaft (2) has got three gears D, E and F and rotates at the same place and cannot move. The shaft (1) which is above the intermediate shaft has got three set of gears A, B and C mounted on it by keys. These three set of gears can be made to slide on the shaft with the help of a lever. This movement enables the gear A to have contact with the gear D or the gear B with gear E or the gear C with the gear F.

Likewise the spindle shaft (3) which is also splined has three set of gears G, H and I. These three set of gears can be made to slide on the shaft by lever. This sliding movement enables the gear G to have contact with gear D or the gear H with the gear E or the gear I with the gear F. By altering the position of the six gears namely A, B, C, G, H and I the following arrangements can be made within the headstock. Nine different spindle within the headstock. Nine different spindle speeds are obtained.

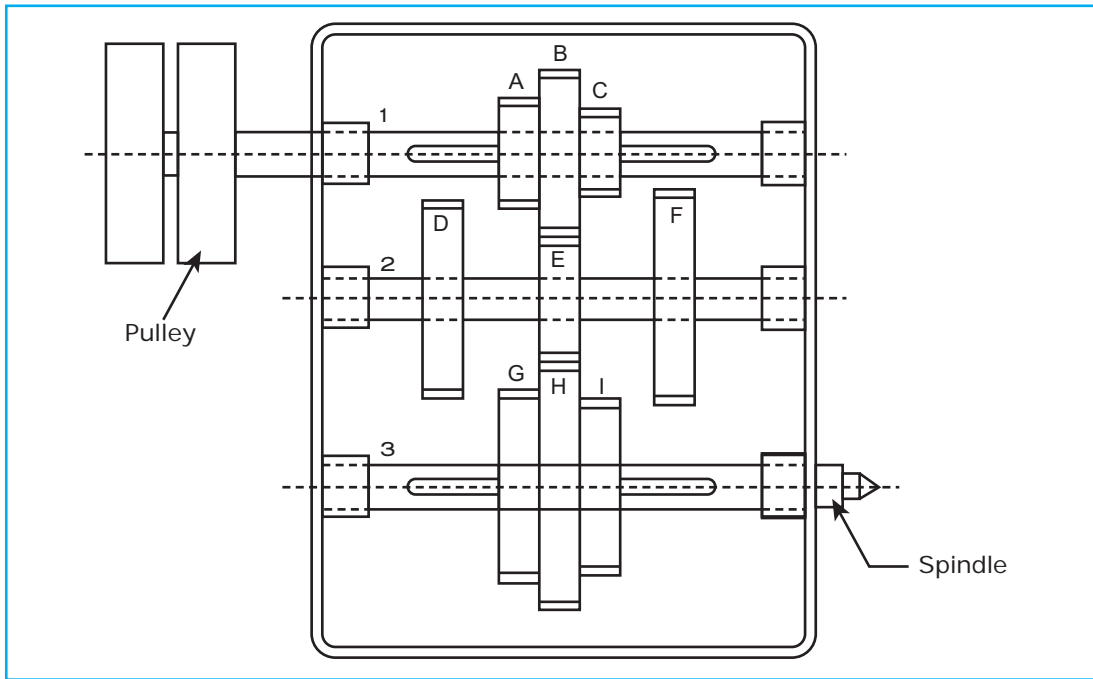

Gear Box

1. $\frac{A}{D} \times \frac{D}{G}$	2. $\frac{A}{D} \times \frac{E}{H}$	3. $\frac{A}{D} \times \frac{F}{I}$
4. $\frac{B}{E} \times \frac{D}{G}$	5. $\frac{B}{E} \times \frac{E}{H}$	6. $\frac{B}{E} \times \frac{F}{I}$
7. $\frac{C}{F} \times \frac{D}{G}$	8. $\frac{C}{F} \times \frac{E}{H}$	9. $\frac{C}{F} \times \frac{F}{I}$

- a. Capstan lathe
- b. Turret lathe
- 5. Automatic lathe
- 6. Special purpose lathe
 - a. Wheel lathe
 - b. Gap bed lathe
 - c. T – lathe
 - d. Duplicating lathe

1.12 Types of lathe

Various designs and constructions of lathe have been developed to suit different machining conditions and usage. The following are the different types of lathe.

1. Speed lathe
 - a. Centering lathe
 - b. Wood working lathe
 - c. Polishing lathe
 - d. Metal spinning lathe
2. Bench lathe
3. Tool room lathe
4. Semi Automatic lathe

Speed lathe

Spindle of a speed lathe operates at very high speeds (approximately at a range of 1200 to 3200 rpm) and so it is named so. It consists of a headstock, a tailstock, a bed and toolslide only. Parts like leadscrew, feed rod and apron are not found in this type of lathe.

1. Centering lathes are used drilling centre holes.
2. The wood working lathes are meant for working on wooden planks.

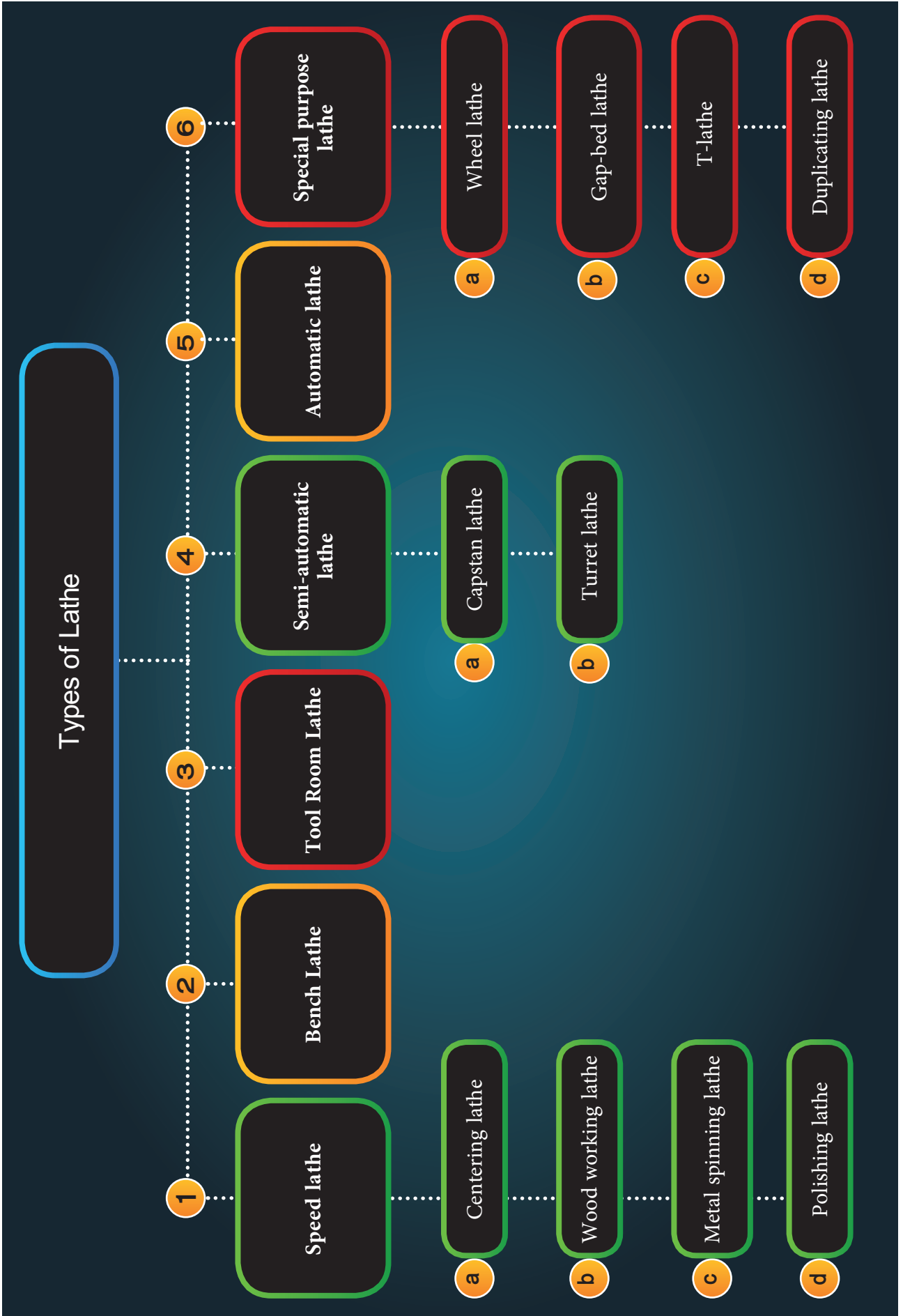

3. Metal spinning lathes are useful in making tumblers and vessels from sheet metal.
4. Polishing of vessels is carried out in polishing lathe.

Bench lathe

Bench lathe is a small lathe generally mounted on a bench. It consists of all the parts of an engine lathe. It is used for small works like machining tiny and precise parts and parts of measuring instruments.

Tool room lathe

A tool room lathe has similar features of an engine lathe but is accurately built and has wide range of spindle speeds to perform precise operations and different feeds. It is costlier than a centre lathe. This is mainly used for precision works like manufacturing tools, dies, jigs, fixtures and gauges.

Semi Automatic lathe

Turret and capstan lathes are known as semi-automatic lathes. These lathes are

used for production work where large quantities of identical work pieces are manufactured. They are called semi-automatic lathes as some of the tasks are performed by the operators and the rest by the machines themselves.

There are two way tool posts in the machine namely four way tool post and rear tool post. Four tools can be mounted on the four way post and parting tool is mounted on the rear tool post. The tailstock of an engine lathe is replaced by a hexagonal turret. As many tools may be fitted on the size side of the turret, different types of operations can be performed on a workpiece without resetting of tools.

Advantages

1. Machining operations can be done in this machine by semi skilled operators.
2. Large quantity of product can be produced quickly.
3. The cost of production is less.

The tool heads of a turret lathe and a capstan lathe are illustrated in figure.

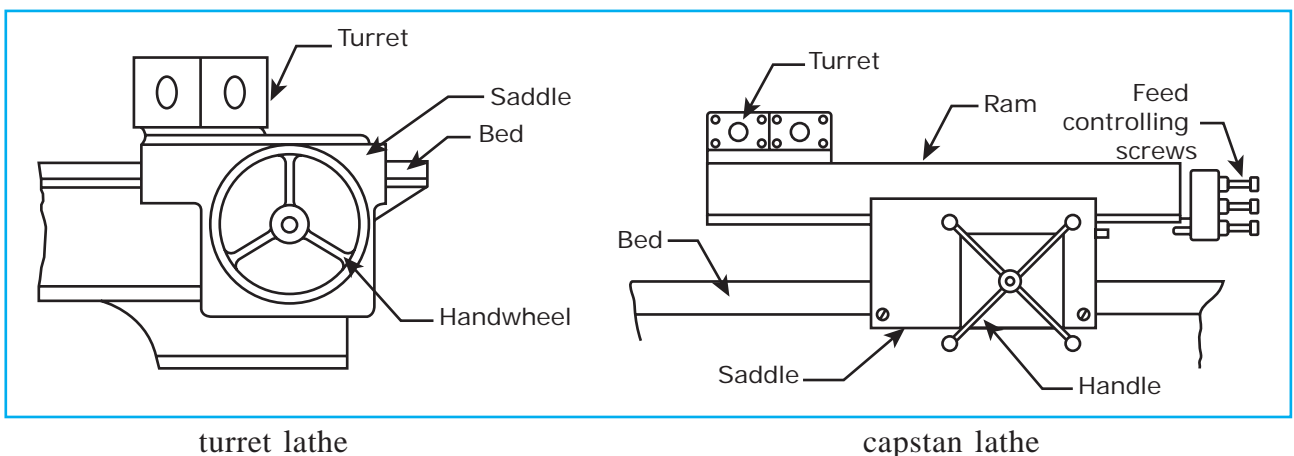

Automatic lathe

Automatic lathes are operated with complete automatic control. They are high speed, mass production lathe. An operator can look after more than one automatic lathe at a time.

Special purpose lathe

Special purpose lathes are used for special purposes and for jobs, which cannot be accommodated and conveniently machined on a standard lathe. Wheel lathe, 'T' lathe duplicating lathe are some examples of special purpose lathe.

1.13 Differences between a turret lathe and a capstan lathe

S.No	Turret lathe	Capstan lathe
1.	Turret tool head is directly fitted on the saddle and both of them appear like one unit.	Turret head is mounted on a slide called ram which is mounted on the saddle.
2.	Saddle is moved to provide feed to the tool.	To provide feed to the tool, saddle is locked at a particular point and the ram is moved.
3.	It is difficult to move the saddle for feed.	It is easy to move the ram for feed.
4.	As the saddle can be moved along the entire length of the bed. It is suitable for longer workpieces.	As the movement of the ram is limited, it is suitable for machining shorter workpieces only.
5.	To index the turret tool head, a clamping lever is released and the turret is rotated manually.	When the handwheel for the ram is reversed, the turret tool head is indexed automatically.
6.	Limit dogs are used to control the distance of tool movement.	To control the distance of tool movement, feed stop screws are provided at the rear side of the turret.
7.	Some turret lathes have the facility of moving the turret at right angles to the lathe axis.	No such facility.
8.	Heavy and sturdy.	Lighter in construction.
9.	Suitable for machining heavy and large workpieces.	Only small and light workpieces are machined.
10.	Machining can be done by providing more depth of cut and feed.	Only limited amount of feed and depth of cut are provided for machining.

1.14 Specification of lathe

The size of a lathe is specified by the following points

1. The length of the bed.
2. Maximum distance between live and dead centres.
3. The height of centres from the bed.
4. The swing diameter
 - a. The swing diameter over bed – It refers to the largest diameter of the work that will be rotated without touching the bed.
 - b. The swing diameter over carriage – It refers to the largest diameter of the work that will revolve over the saddle.
5. The bore diameter of the spindle.
6. The width of the bed.
7. The type of the bed.
8. Pitch value of the lead screw.
9. Horse power of the motor.
10. Number and range of spindle speeds.
11. Number of feeds.
12. Spindle nose diameter.
13. Floor space required.
14. The type of the machine

1.15 Work Holding Devices used in a lathe

The work holding devices are used to hold and rotate the workpieces along with the spindle. Different work holding devices are used according to the shape, length, diameter and weight of the workpiece and the location of turning on the work.

They are,

1. Chucks
2. Face plate
3. Driving plate

4. Catch Plate
5. Carriers
6. Mandrels
7. Centres
8. Rests

Chucks

Work pieces of short length, large diameter and irregular shapes, which cannot be mounted between centres, are held quickly and rigidly in chuck. There are different types of chucks namely, three jaw universal chuck, four jaw independent chuck, Magnetic chuck, Collect chuck and Combination chuck.

Three Jaw self-centering chuck

The three jaws fitted in the three slots may be made to slide at the same time by an equal amount by rotating any one of the three pinions by a chuck key. This type of chuck is suitable for holding and rotating regular shaped workpieces like round or hexagonal rods about the axis of the lathe.

Advantages

1. The work is held simply and quickly because of the three jaws are moved to slide at the same time.
2. So, time is saved.
3. It is suitable for apprentice.

Disadvantage

1. Workpieces of irregular shapes cannot be held by this chuck.

Four jaw independent chuck

There are four jaws in this chuck. Each jaw is move independently by rotating a screw with the help of a chuck key. A particular jaw may be moved according to the shape of the work. Hence this type of chuck can hold works of irregular

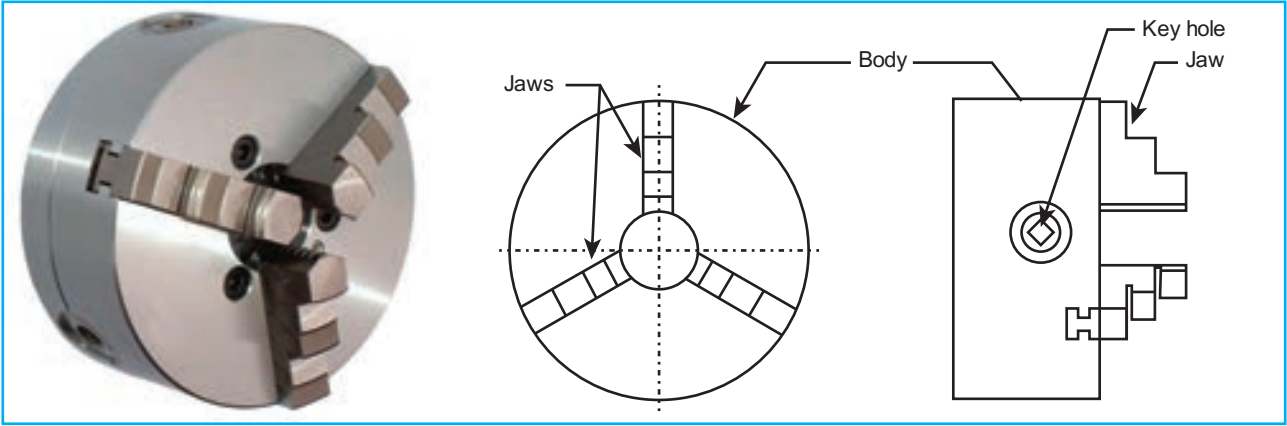

3D-Three Jaw self-centering chuck

Three Jaw self-centering chuck

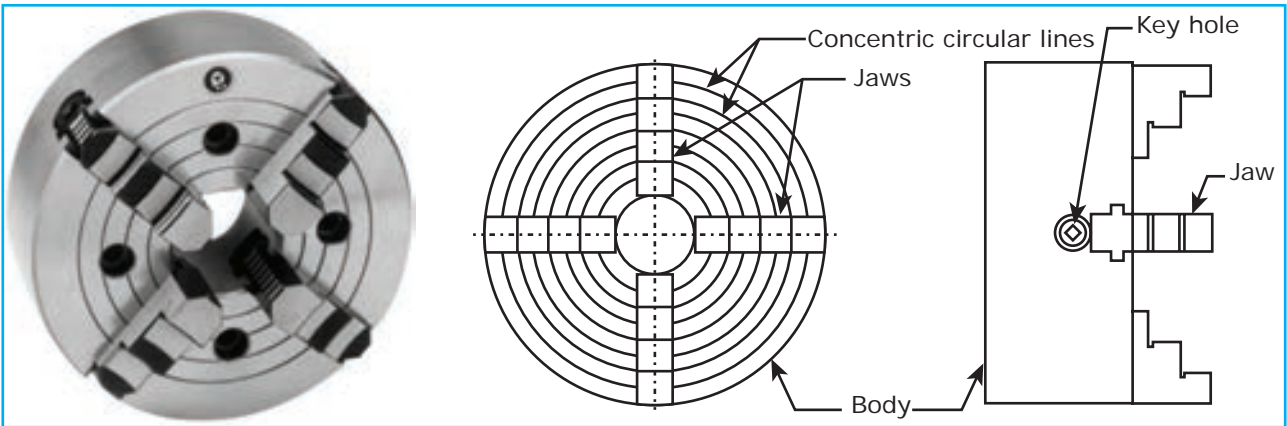

3D-Four Jaw independent chuck

Four Jaw independent chuck

shapes. Concentric circles are inscribed on the face of the chuck to enable quick centering of the workpiece.

2. Experienced turners can set the work about the axis quickly.

Disadvantages

1. It requires more time to set the work aligned with the lathe axis because each jaw is moved independently.

Magnetic chuck

The holding power of this chuck is obtained by the magnetic flux radiating from the electromagnet placed inside the chuck. Magnets are adjusted inside the chuck to hold or release the work. Workpiece made



Magnetic chuck

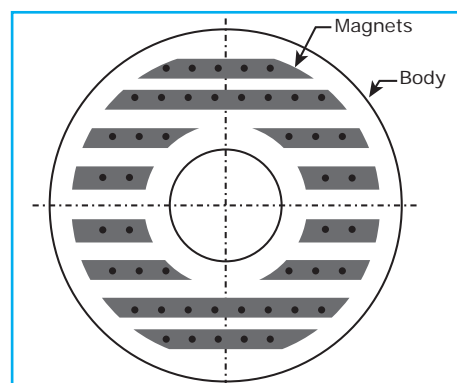

of magnetic material only are held in this chuck. Very small, thin and light works which cannot be held in an ordinary chuck are held in this chuck.

Face plate

Face plate is used to hold large, heavy and irregular shaped workpieces which cannot be conveniently held between centres. It is circular disc bored out and threaded to fit to the nose of the lathe spindle. It is provided with radial plain and ‘T’ – slots for holding the work by bolts and clamps.

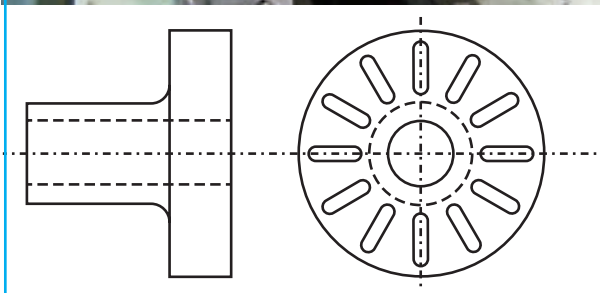
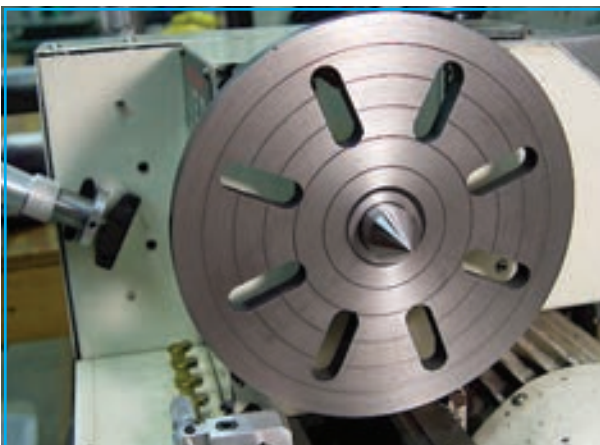

Face plate

Driving plate

The driving plate is used to drive a workpiece when it is held between centres. It is a circular disc screwed to the nose of the lathe spindle. It is provided with small bolts or pins on its face. Work pieces fitted inside straight tail carriers are held and rotated by driving plates.

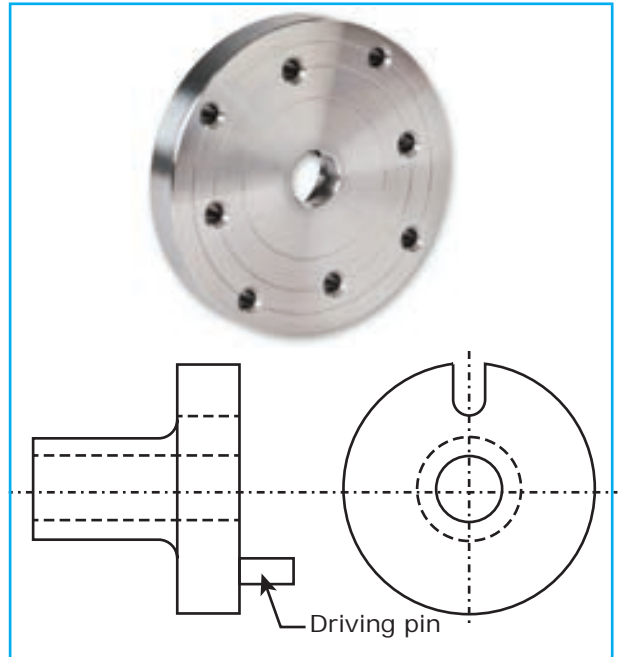

Driving plate

Catch plate

When a workpiece is held between centres, the catch plate is used to drive it. It is a circular disc bored and threaded at the centre. Catch plates are designed with ‘U’-slots or elliptical slots to receive the bent tail of the carrier. Positive drive between the lathe spindle and the workpiece is affected when the workpiece fitted with the carrier fits into the slot of the catch plate.

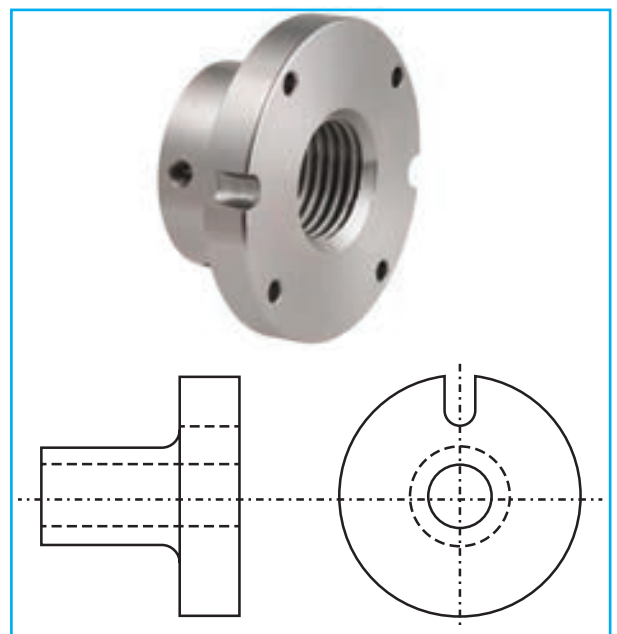

Catch plate

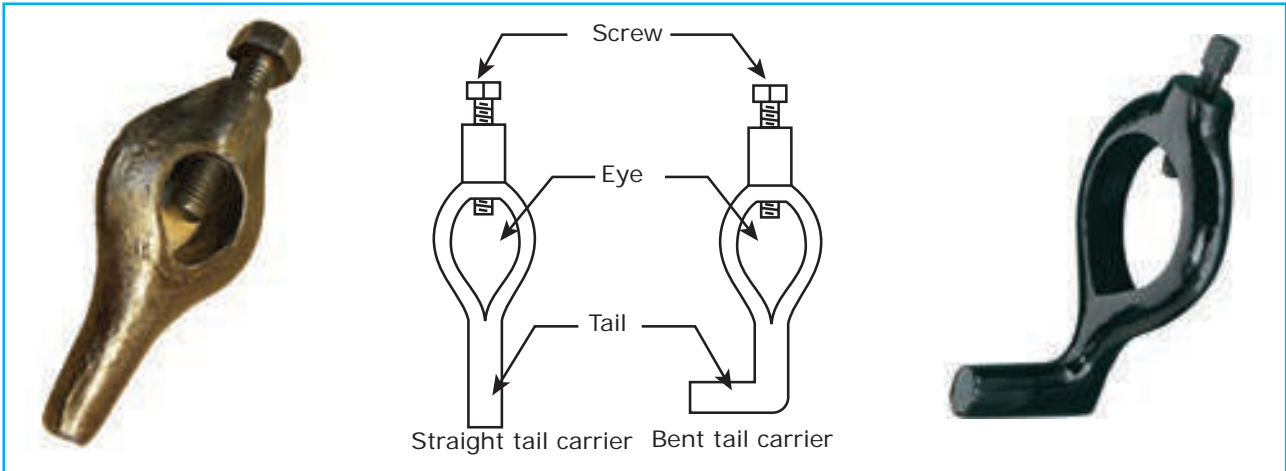

Straight tail carrier

Bent tail carrier

Carrier

When a workpiece is held and machined between centrers, carriers are useful in transmitting the driving force of the spindle to the work by means of driving plates and catch plates. The work is held inside the eye of the carrier and tightened by a screw. Carriers are of two types and they are:

1. Straight tail carrier
2. Bent tail carrier

Straight tail carrier is used to drive the work by means of the pin provided in the driving plate. The tail of the bent tail carrier fits into the slot of the catch plate to drive the work.

Mandrel

A previously drilled (or) bored workpiece is held on mandrel to be driven in a lathe and machined. There are centre holes provided on both faces of the mandrel. The live centre and the dead centre fit into the centre holes. A carrier is attached at the left side of the mandrel. The mandrel gets the drive either through a catch plate or a driving plate. The workpiece rotates along with the mandrel. There are several types of mandrels and they are:

1. Plain mandrel
2. Step mandrel
3. Gang mandrel
4. Screwed mandrel
5. Collar mandrel
6. Cone mandrel
7. Expansion mandrel

Plain mandrel

The body of the plain mandrel is slightly tapered to provide proper gripping of the workpiece. The taper will be around 1 to 2 mm for a length of 100 mm. It is also known as solid mandrel. This type is mostly commonly used and has wide application.

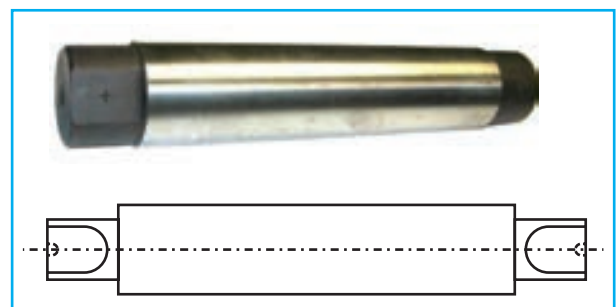

Plain mandrel

Screwed mandrel

It is threaded at one end and a collar is attached to it. Workpieces having internal threads are screwed on to it against the collar for machining.

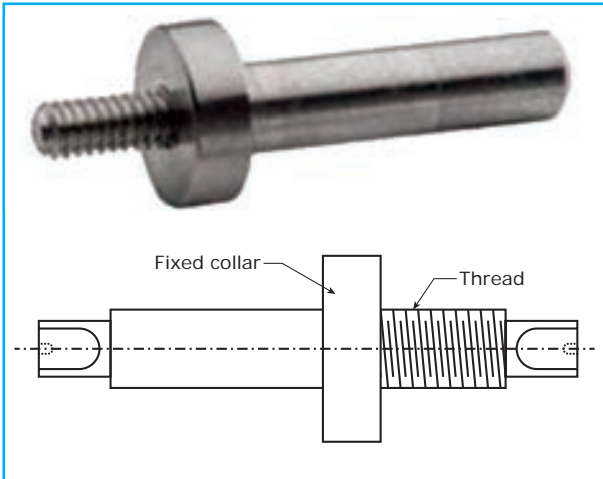

Screwed mandrel

Centres are useful in holding the work in a lathe between centres. The shank of a centre has morse taper on it and the face is conical in shape. There are two types of centres namely

1. Live centre
2. Dead centre

Live centre



The live centre is fitted on the headstock spindle and rotates with the work.

Dead centre

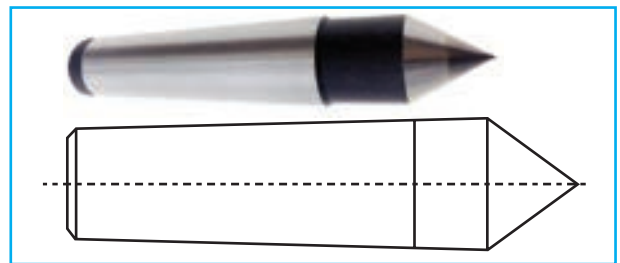

Centres



Holding a work between Live and Dead centres

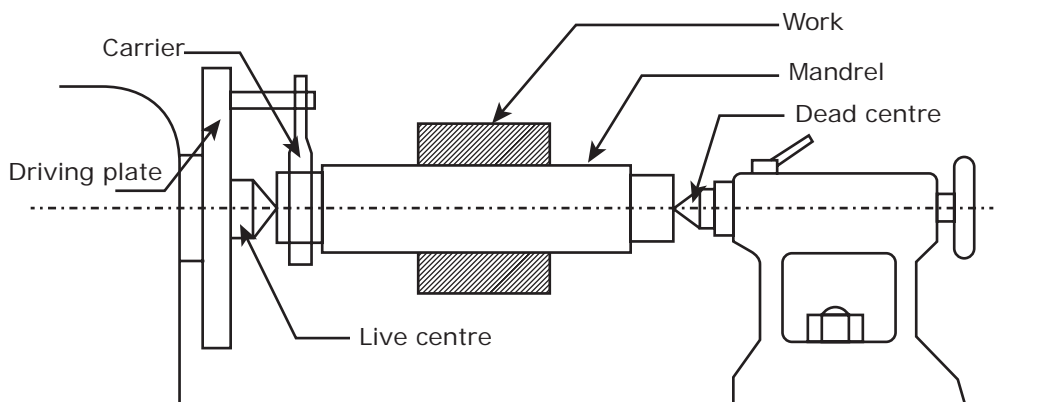

Holding a work between Live and Dead centres

The centre fitted on the tailstock spindle is called dead centre. It is useful in supporting the other end of the work. Centres are made of high carbon steel and hardened and then tempered. So the tips of the centres are wear resistant. Different types of centres are available according to the shape of the work and the operation to be performed.

Rests

A rest is a mechanical device to support a long slender workpiece when it is turned between centres or by a chuck. It is placed at some intermediate point to prevent the workpiece from bending due to its own weight and vibrations setup

due to the cutting force. There are two types of rests

1. Steady rest
2. Follower rest

Steady rest

Steady rest is made of cast iron. It may be made to slide on the lathe bedways and clamped at any desired position where the workpiece need support. It has three jaws. These jaws can be adjusted according to the diameter of the work. Machining is done upon the distance starting from the headstock to the point of support of the rest. One or more steady rests may be used to support the free end of a long work.

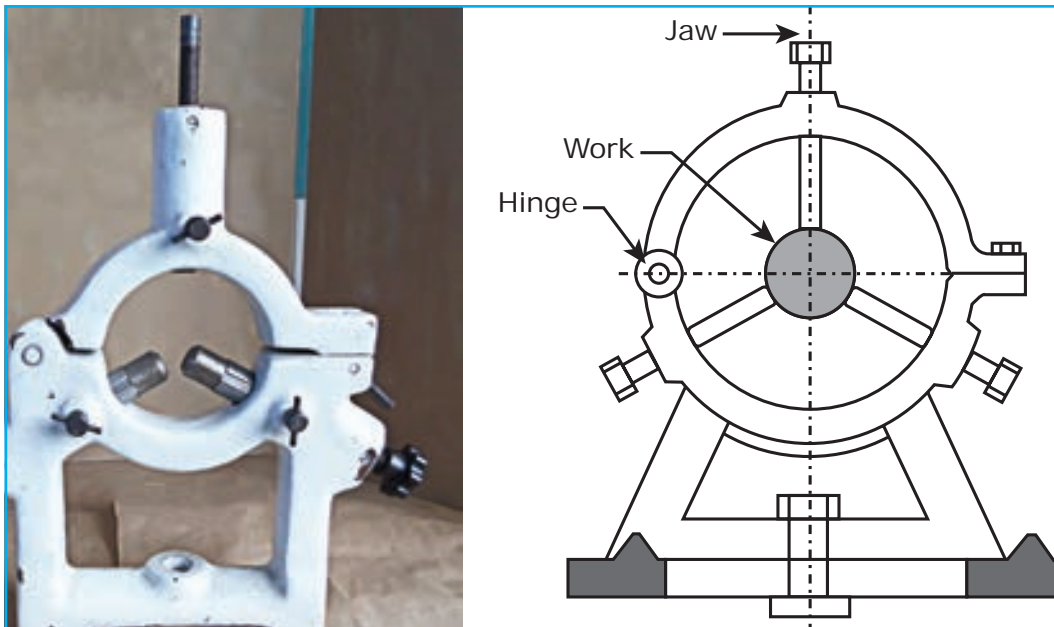

Steady Rest

Follower rest

It consists of a 'C' like casting having two adjustable jaws to support the workpiece. The rest is bolted to the back end of the carriage. During machining, it supports the work and moves with the carriage. So, it follows the tool to give

continuous support to the work to be able to machine along the entire length of the work.

Note: In order to reduce friction between the work and the jaws, proper lubricant should be used.

Work Holding Devices

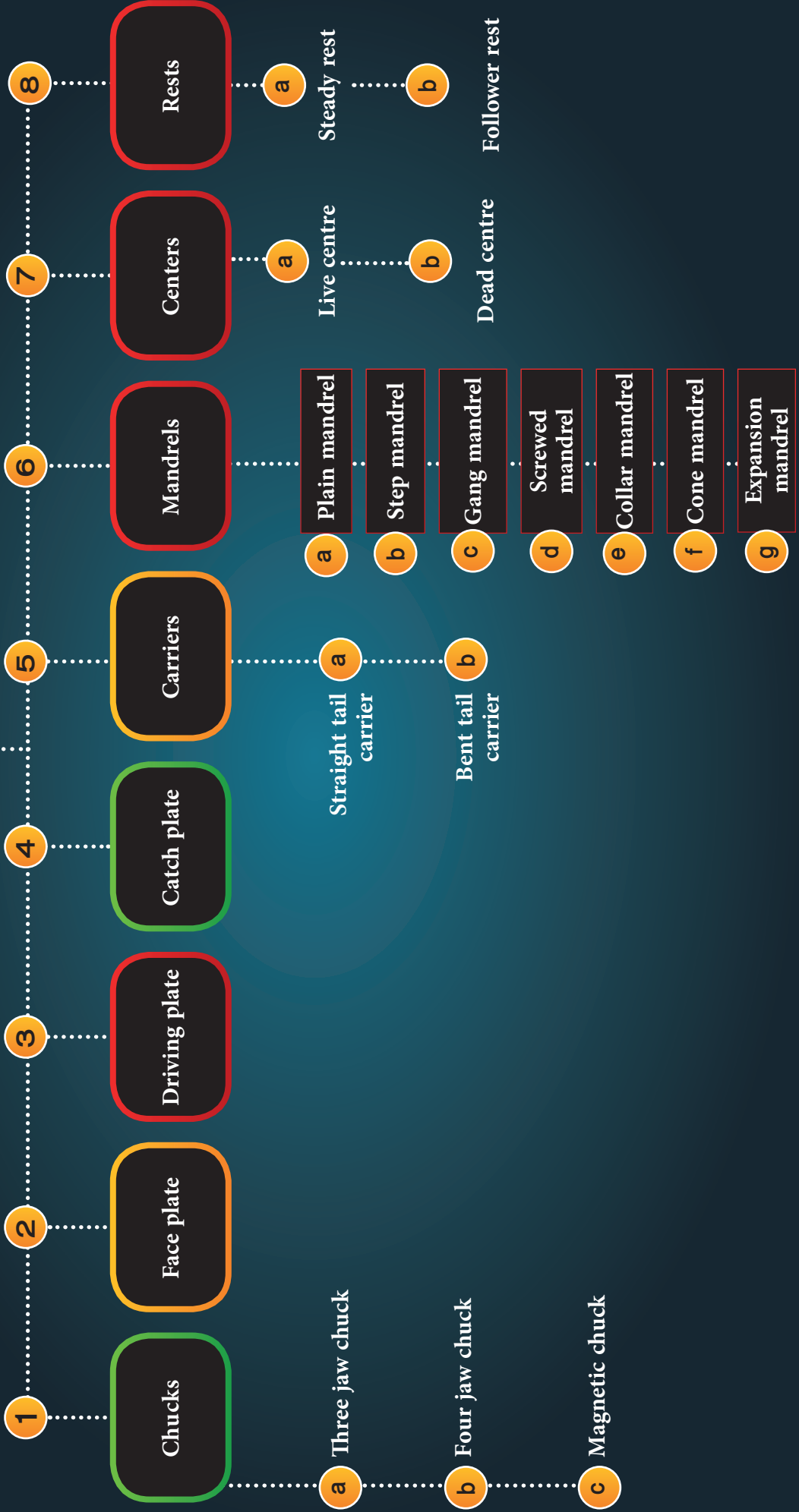

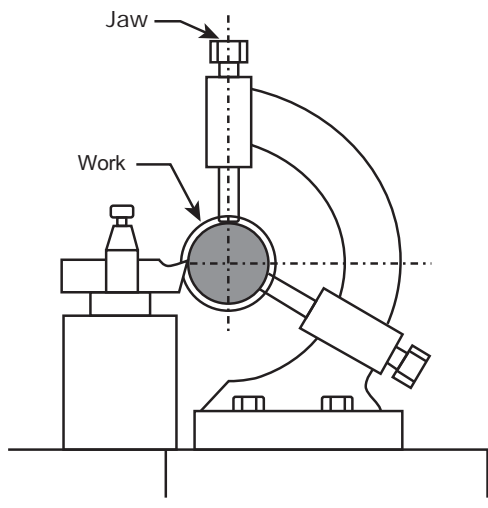

Follower rest

1.16 Cutting speed, Feed and Depth of cut in lathe

The cutting speed is the distance travelled by a point on the outer surface of the work is one minute.

It is expressed in meters per minute.

$$\text{Cutting speed} = \frac{\pi DN}{1000} \text{ m/min}$$

Where,

D – is the diameter of the work in mm

N – is the r.p.m of the work.

Feed

The feed of a cutting tool in a lathe work is the distance the tool advance for each revolution of the work.

Feed is expressed in millimeters per revolution.

Depth of cut

The depth of cut is the perpendicular distance measured from the machined surface to the uncut surface of the workpiece. It is expressed in millimeters.

In a lathe, the depth of cut is expressed as follows

$$\text{Depth of cut} = \frac{d_1 - d_2}{2}$$

Where,

d_1 – diameter of the work surface before machining

d_2 – diameter of the machined surface

1.17 Tools used in a lathe

Tools used in lathe are classified as follows

A. According to the construction, the lathe tools are classified into three types

1. Solid tool
2. Brazed tipped tool
3. Tool bit and tool holders

B. According to the operation to be performed, the cutting tools are classified as

1. Turning tool
2. Thread cutting tool
3. Facing tool
4. Forming tool
5. Parting tool
6. Grooving tool
7. Boring tool
8. Internal thread cutting tool
9. Knurling tool

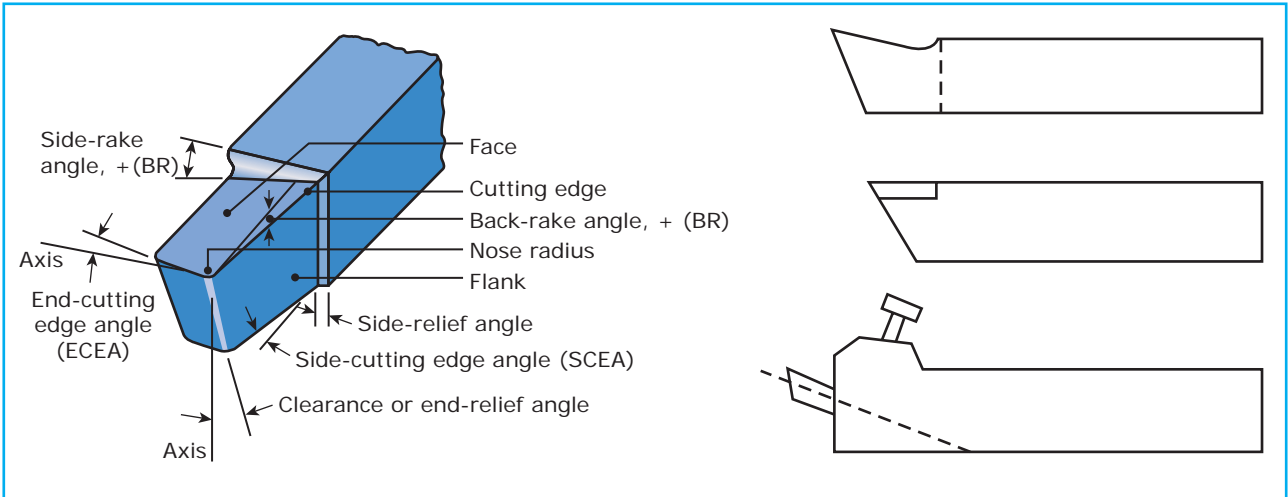

Tools used in a lathe

C. According to the direction of feed movement, the following tools are used

1. Right hand tool
2. Left hand tool
3. Round nose tool

7. Under cutting
8. Taper turning
9. Thread cutting

1.18 Operations performed in lathe

Various operations are performed in a lathe other than plain turning.



Other works are done in lathe

1. Drilling
2. Reaming
3. Boring
4. Grinding
5. Milling
6. Key ways



Turning

The work is turned straight when it is made to rotate about the lathe axis. The purpose of turning is to produce a cylindrical surface by removing excess metal from the workpiece.

There are

1. Facing
2. Turning
 - a. Straight turning
 - b. Step turning
3. Chamfering
4. Grooving
5. Forming
6. Knurling

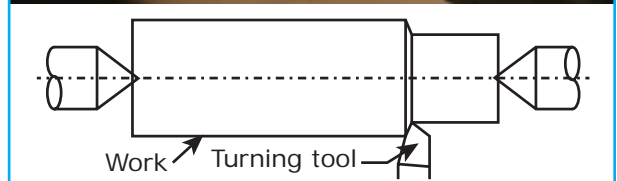
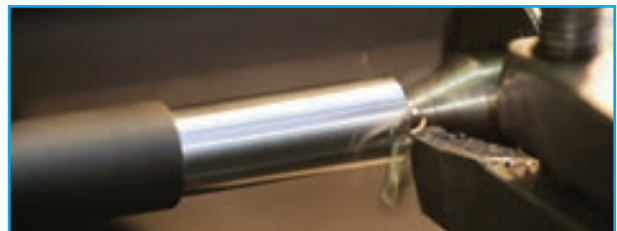

Turning

Chamfering

Chamfering is the operation of beveling the extreme end of the workpiece. The form tool used for taper turning may be used for this purpose. Chamfering is an essential operation after thread cutting so that the nut may pass freely on the threaded workpiece.

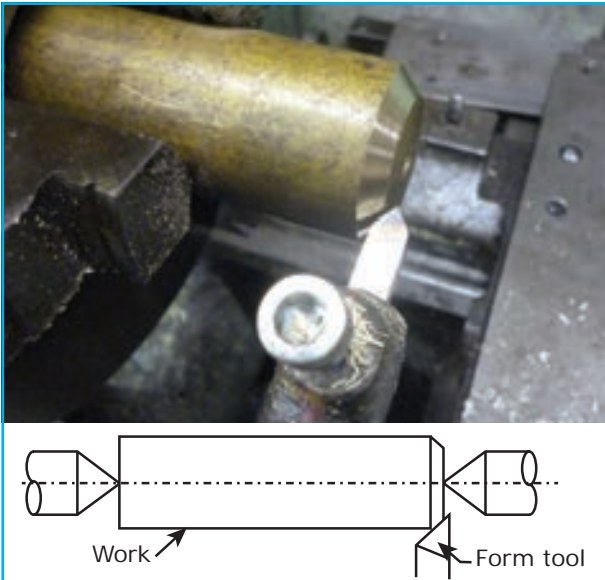

Chamfering

Undercutting

Undercutting is done

1. At the end of a hole
2. Near the shoulder of stepped cylindrical surfaces
3. At the end of the threaded portion in bolts

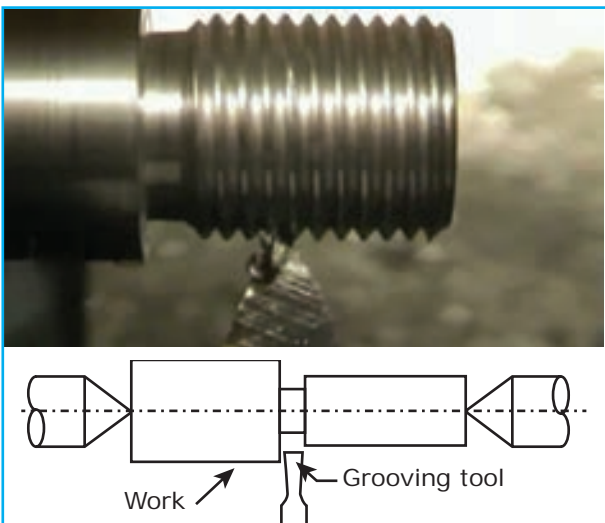

Under Cutting

It is a process of enlarging the diameter if done internally and reducing the diameter if done externally over a short length. It is useful mainly to make fits perfect. Boring tools and parting tools are used for this operation.

Knurling

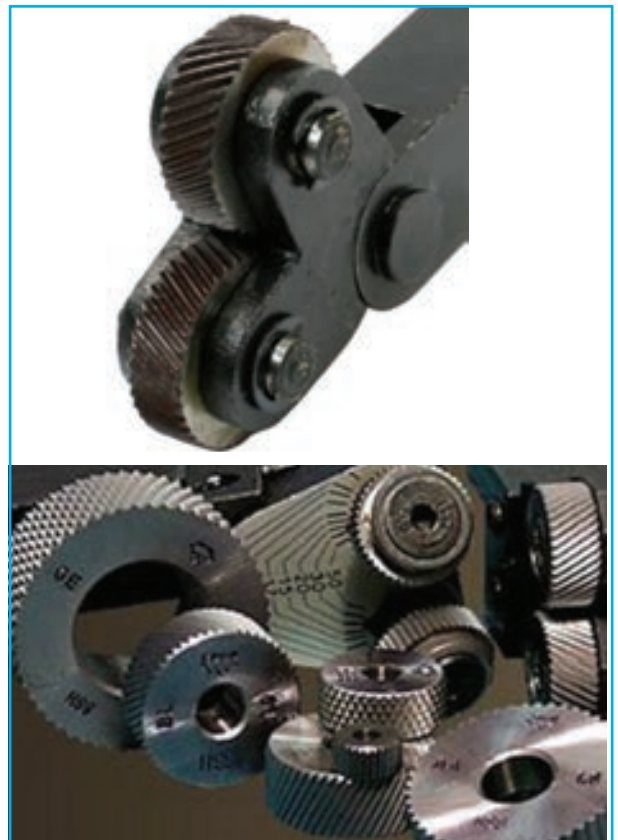
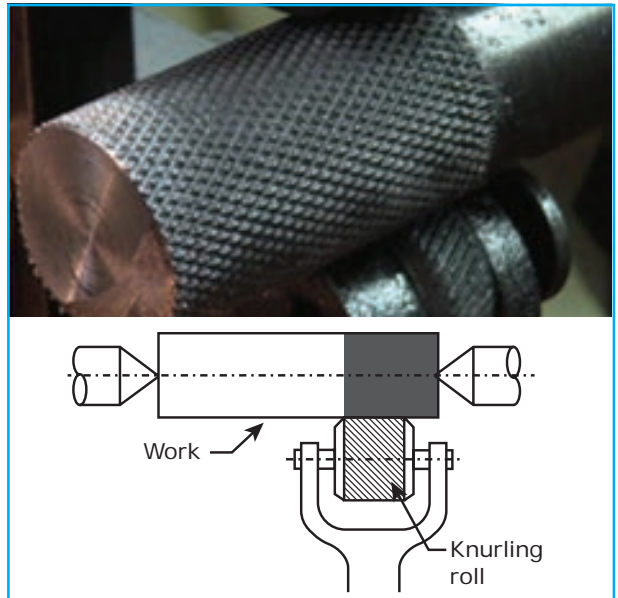

Knurling

Knurling is the process of embossing a diamond shaped pattern on the surface of the workpiece. The knurling tool holder has one or two hardened steel rollers with edges of required pattern. The tool holder is pressed against the rotating work. The rollers emboss the required pattern. The tool holder is fed automatically to the required length. Knurls are available in coarse, medium and fine pitches. The patterns may be straight, inclined or diamond shaped.

The purpose of knurling is

1. To provide an effective gripping surface.
2. To provide better appearance to the work.
3. To slightly increase the diameter of the work.

1.19 Taper turning

Taper

A taper may be defined as a uniform increase or decrease in diameter of a piece of work measured along its length.



Taper turning

Taper turning method

1. Form tool method
2. Compound rest method

3. Tailstock set over method
4. Taper turning attachment method
5. Combined feed method

Form tool method

A broad nose tool is ground to the required length and angle. It is set on the work by providing feed to the cross-slide. When the tool is fed into the work at right angles to the lathe axis, a tapered surface is generated.

This method is limited to turn short lengths of taper only. The length of the taper is shorter than the length of the cutting edge. Less feed is given as the entire cutting edge will be in contact with the work.

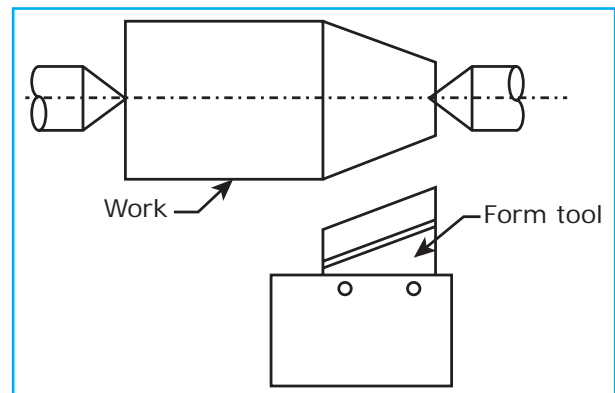

Form tool method

Compound Rest Method

The compound rest of the lathe is attached to the circular base graduated in degrees, which may be swiveled and clamped at any desired angle. The angle of taper is calculated using the formula.

$$\tan \theta = \frac{D - d}{l}$$

Where

D – Larger diameter

d – Small diameter

l – Length of the taper

The compound is swiveled to the angle as above and clamped. Feed is given to the compound slide to generate the required taper.

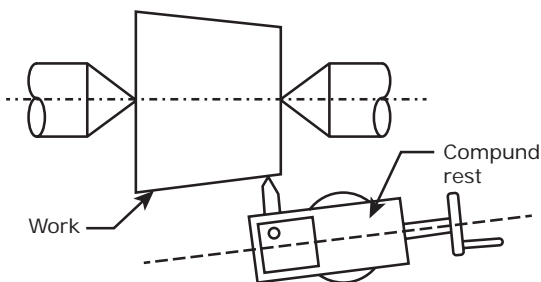

Compound Rest Method

Note On doing taper turning in compound rest method, feed will be given to the tool from small diameter to large diameter.

Advantage

Taper turning can be done on outer surface of the workpiece and inner surface of the hole.

Disadvantage

1. This method is not suitable for long workpiece, because compound slide moves only small distance.
2. This method is done manually so, it takes more time and the productivity is less.

Tailstock setover method

Turning taper by the setover method is done by shifting the axis of rotation of the workpiece at an angle to the lathe axis and feeding the tool parallel to the lathe axis. The construction of tailstock is designed to have two parts namely the base and the body. The base is fitted on the bed guideways and the body having the dead centre can be moved at cross to shift the lathe axis.

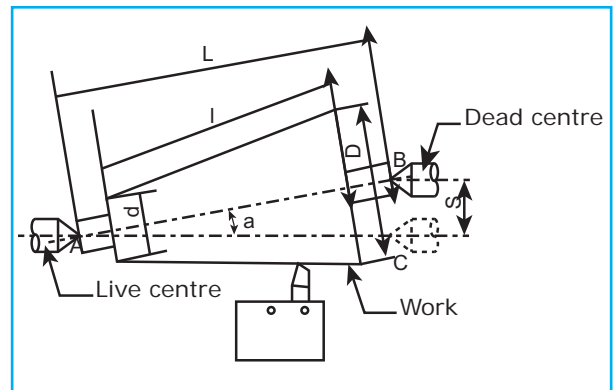

The amount of setover-S, can be calculated as follows

$$S = \frac{D-d}{2} \times \frac{L}{l}$$

Where,

S – Amount of setover

D – Larger diameter

d – Smaller diameter

L – Length of the work

l – Length of the taper

The dead centre is suitably shifted from its original position to the calculated distance. The work is held between centres and longitudinal feed is given by the carriage to generate the taper.

Note While doing taper turning in a stepped turned work piece, each of the stepped taper turning must be calculated individually.

Advantages

1. Taper turning can be done to full length of the workpiece.
2. Taper thread cutting can also be cut in this method.

Diadvantages

1. This type of taper turning can be done up to angle of 8° .
2. Internal taper turning cannot be done by this method.

1.20 Thread Cutting

Thread cutting is one of the most important operations performed in a lathe. The process of thread cutting is to produce a helical groove on a cylindrical surface by feeding the tool longitudinally.

1. The job is revolved between centres or by a chuck. The longitudinal feed should be equal to the pitch of the thread to be cut per revolution of the work piece.

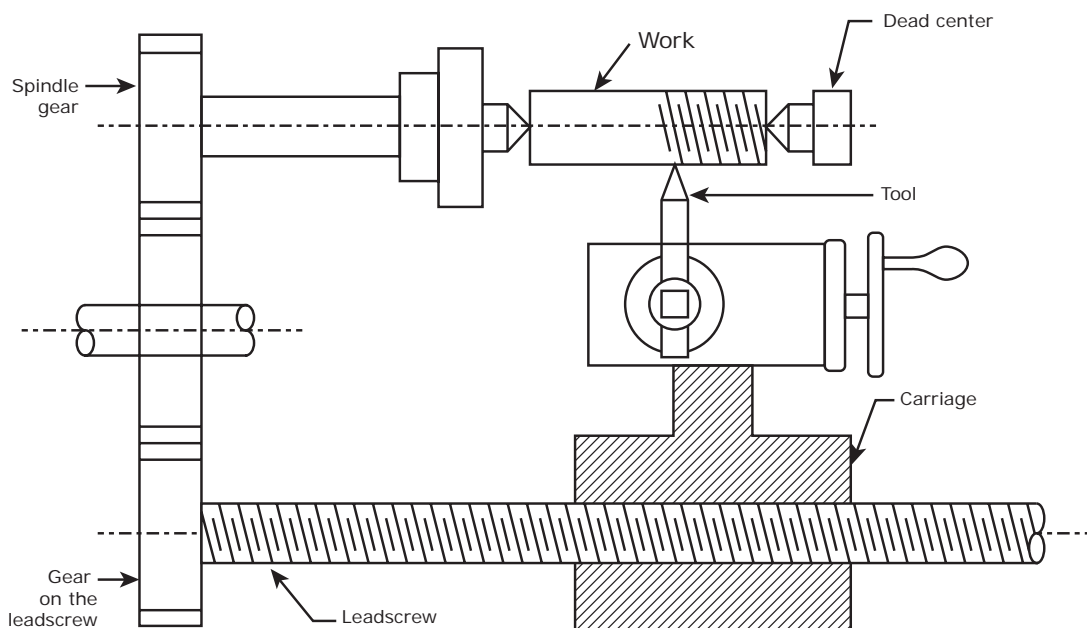
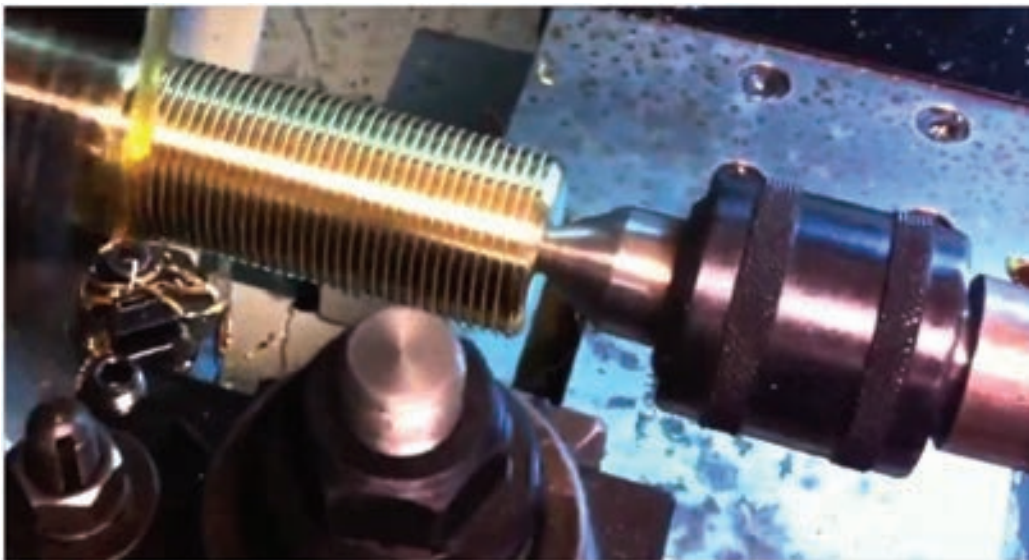

Thread Cutting

2. The carriage should be moved longitudinally obtained feed through the leadscrew of the lathe.
3. A definite ratio between the longitudinal feed and rotation of the head stock spindle should be found out. Suitable gears with required number of teeth should be mounted on the spindle and the leadscrew.
5. The position of the tumbler gears are adjusted according to the type of the thread (right hand or left hand).
6. Suitable spindle speed is selected and it is obtained through back gears.
7. Half nut lever is engaged at the right point as indicated by the thread chasing dial.

Calculation for change – gear

$$\frac{\text{TPI on leadscrew}}{\text{TPI on work}} = \frac{\text{driver teeth}}{\text{driven teeth}}$$

By using the above formula, calculate the thread to be cut and connect the gear on the spindle and the gear on leadscrew.

4. A proper thread cutting tool is selected according to the shape of the thread. It is mounted on the toolpost with its cutting edge at the lathe axis and perpendicular to the axis of the work.
8. Depth of cut is set suitably to allow the tool to make a light cut on the work.
9. When the cut is made for required length, the half nut lever is disengaged. The carriage is brought back to its original position and the above procedure is repeated until the required depth of the thread is achieved.
10. After the process of thread cutting is over, the thread is checked by suitable gauges.

ACTIVITIES

1. To make an arrangement the students to visit Government Industrial Training Institute, Polytechnics and Engineering colleges nearby the school and learn about the types of lathe and its working principle.
2. To give practice to the students performed different types of operations in a lathe.

Questions

Part – I

Choose the correct answer

1. Lathe was invented by
 - a. Henry Maudslay
 - b. Eli Whitney
 - c. James Nasmyth
 - d. Michael Faraday
2. The tool used in lathe is a
 - a. Multipoint cutting tool
 - b. Single point cutting tool
 - c. Slitting saw tooth cutting tool
 - d. Parting tool

3. Polishing lathe is a type of
 - a. Engine lathe
 - b. Tool room lathe
 - c. High speed lathe
 - d. Automatic lathe
4. The spindle speed of high speed lathe is around
 - a. 600-1000 rpm
 - b. 1200-3200 rpm
 - c. 2000-2400 rpm
 - d. 3500-4000 rpm



5. A part used in taper turning is
 - a. Cross-slide
 - b. Compound rest
 - c. Saddle
 - d. Apron
6. The formula for finding the cutting speed in a lathe is

a. $\frac{\pi DN}{1000}$	b. $\frac{d_1 - d_2}{2l}$
c. $\pi r^2 h$	d. $\frac{D - d}{2} \times \frac{L}{l}$

Part – II

Answer the following questions in one or two sentences: (3 marks)

7. What is turning?
8. What are the uses of tool room lathe?
9. Mention the special features of turret and capstan lathe.
10. What is swing diameter?

11. What are the special features of V-bed in a lathe?
12. What are the uses of back gear in a lathe?
13. Define ‘Cutting speed’ in a lathe.
14. What is the use of Lead screw in a lathe?
15. Mention the use of a face-plate.
16. Mention the formula to use the cutting of a thread, in a lathe.

Part – III

Answer the following questions in about a page (5 marks)

17. List out the types of lathe.
18. Mention any five differences between a turret and a capstan lathe.
19. What are the parts in the carriage of a lathe? Explain any one part.
20. Mention the different specifications of a lathe.
21. Sketch and explain the taper-turning by using the form-tool method.

Part – IV

Answer the following questions in detail (10 Marks)

22. Draw a neat sketch of a lathe and label its parts.
23. Explain with neat sketch of a step-cone pulley drive mechanism.
24. Explain any two operations performed in lathe with neat sketch.
25. Explain any two work holding devices in a lathe with suitable diagrams.

Drilling Machine



Learning Objectives

- Students to understand how to drill the holes in work pieces, different types of machining operations related to drilling process and various uses of drilling process in industries and other fields in future life.



Thaam inburuvadhu ulagin purakandu
Kaamuruvar katrarinh dhaar. –Kural 399

When the learned see that their learning contributes to make the world happy. They are pleased and pursue their learning more.

CONTENTS

- | | |
|---|---|
| 2.1 Introduction of Drilling Machine | 2.11 Deep - hole drilling machine |
| 2.2 Drilling Method | 2.12 Size of a drilling machine |
| 2.3 Construction of a drilling machine | 2.13 Drill spindle assembly |
| 2.4 Types of drilling machines | 2.14 Work - holding devices. |
| 2.5 Portable drilling machine | 2.15 Tools used in a drilling machine |
| 2.6 Sensitive drilling machine | 2.16 Twist - drill nomenclature |
| 2.7 Up-right drilling machine | 2.17 Tool - holding devices |
| 2.8 Radial drilling machine and its special features. | 2.18 Drilling machine operations |
| 2.9 Gang drilling machine | 2.19 Cutting speed. Feed and depth of cut |
| 2.10 Multi - spindle drilling machine | 2.20 Safety precautions |



The inventor of basic drilling machine is Arthur James Arnot and William Blanch Brain of Melbourne, Australia by using the electric motor, in the year of 1889.



Arthur James Arnot

2.1 Introduction

The Drilling Machine is one of the most important machine tools in a workshop. As regards its importance it is second only to the lathe. It was designed to produce a cylindrical hole of required diameter and depth on work pieces.

Though holes can be made by different machine tools in a shop, drilling machine is designed specifically to perform the operation of drilling and similar operations. Drilling can be done easily at a low cost in a shorter period of time in a drilling machine.

Drilling can be called as the operation of producing a cylindrical hole of required diameter and depth by removing metal by the rotating the cutting edges of a drill bit.

2.2 Method of Drilling

The cutting tool known as drill bit is fitted into the spindle of the drilling machine. A mark of indentation is made at the required location with a center punch. The rotating drill is pressed at the location and is fed into the work. The hole can be made up to a required depth.

2.3 Structure of a drilling machine

The basic parts of a drilling machine are a base, column, drill head and spindle.



3D Method of Drilling

The base made of cast iron may rest on a bench, pedestal or floor depending upon the design. Larger and heavy duty machines are grounded on the floor. The column is mounted vertically upon the base. It is accurately machined and the table can be moved up and down on it. The drill spindle an electric motor and the mechanism meant for driving the spindle at different speeds are mounted on the top of the column. Power is transmitted from the electric motor to the spindle through a flat belt (or) a 'V' belt.





3D Structure of a drilling machine

2.4 Types of drilling machines

Drilling machines are manufactured in different types and sizes according to the type of operation amount of feed. Depth of cut, spindle speeds, method of spindle movement and the required accuracy.

The different types of drilling machines are

1. Portable drilling machine (or) Hand drilling machine.
2. Sensitive drilling machine
3. Upright drilling machine
 - a) Round column section
 - b) Box column section
4. Radial drilling machine
5. Gang drilling machine

6. Multi – spindle drilling machine
7. Deep hole drilling machine.
 - a) Vertical
 - b) Horizontal
8. Automatic drilling machine.

Types of Drilling Machines

1. Portable Drilling Machine (or) Hand Drilling Machine
2. Bench Drilling Machine (or) Sensitive Drilling Machine
3. Upright Drilling Machine
 - a. Box column
 - b. Round column
4. Radial Drilling Machine
5. Gang Drilling Machine
6. Multi–Spindle Drilling Machine
7. Deep Hole Drilling Machine
 - a) Vertical
 - b) Horizontal
8. Automatic Drilling Machine

2.5 Portable drilling machine

The portable drilling machine is shown in the given figure.

Portable drilling machine can be carried and used anywhere in the workshop. It is used for drilling holes on work pieces in any position. Which is not possible in a standard drilling machine. The entire drilling mechanism is compact and small in size and so can be carried anywhere. This type of machine is widely adapted for automobile built – up work. The motor is generally universal type.



Portable drilling machine

These machines can accommodate drills from 12mm to 18 mm diameter. The machine is operated at high speed as smaller size drills are only used.

2.6 Sensitive drilling machine (or) Bench drilling machine

A sensitive drilling machine is shown in the given figure.

DO YOU KNOW? The inventor of sensitive drilling machine is martin. D.Elledge of USA. Year 1958.

It is designed for drilling small holes at high speeds in jobs. High speed and hand feed are necessary for drilling holes. The base of the machine is mounted either on a bench or on the floor. It can handle drills of diameter from 1.5mm to 1.55mm the drill is feed with work purely by hand. The operator can sense of the progress of the drill into work because of hand feed. So it is called sensitive drilling machine.

Super sensitive drilling machines are designed to drill holes as small as 0.35mm in diameter and the spindle of the machine is rotated at a high speed of 2000 rpm or above.

Base

The base is made of cast iron and so can withstand vibrations. It may be mounted on a bench or on the floor. It supports all the other parts of the machine on it.

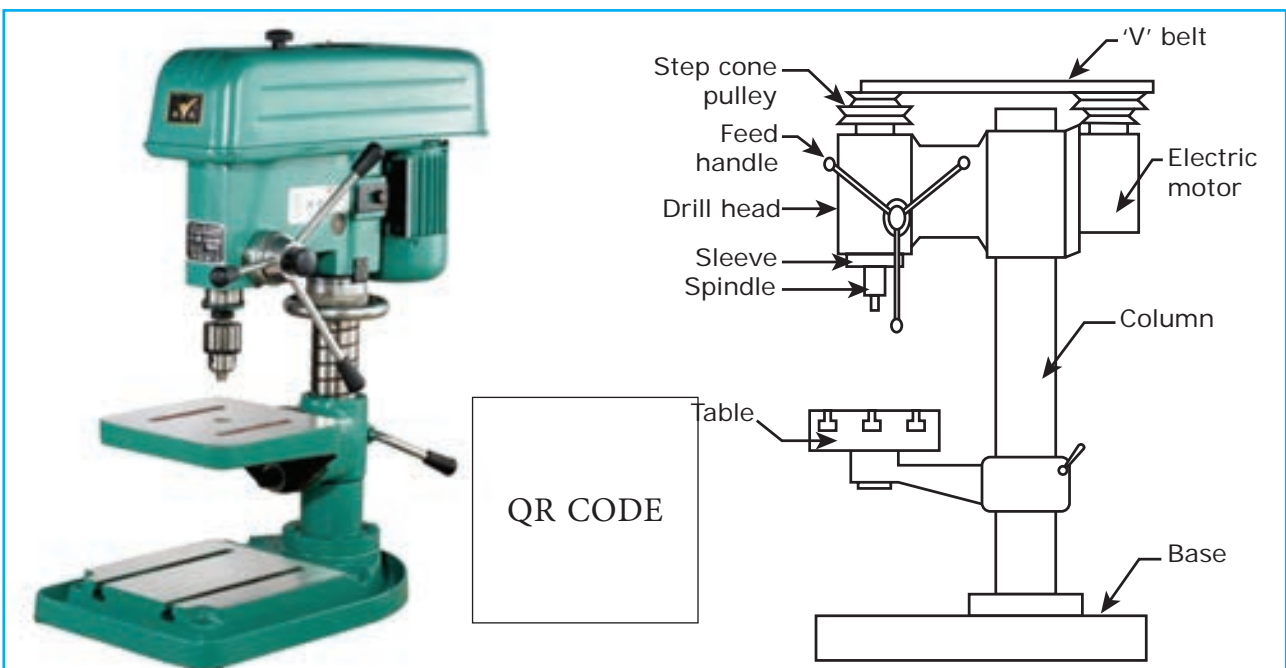

Bench Drilling Machine

Column

The column stands vertically on the base at one end. It supports the work table and the drill head. The drill head has drill spindle and the driving motor on either side of the column.

Work Table

The table is mounted on the vertical column and can be adjusted up and down on it. The table has T- slots on it for holding the work pieces or to hold any other work holding device. The table can be adjusted vertically to accommodate work pieces of different heights and can be clamped at the required position.

Drill head

Drill head is mounted on the top side of the column. The drill spindle and the driving motor are connected by means of a V-belt and cone pulleys. The motion is transmitted to the spindle from the motor by the belt.

The pinion attached to the handle meshes with the rack on the sleeve of the spindle for providing the drill to the required down feed. There is no power feed arrangement in this machine. The spindle rotates at a speed of 50 to 2000rpm.

2.7 Up right drilling machine

The upright drilling machine is designed for handling medium sized work pieces. Though it looks like a sensitive drilling machine, its vertical column is larger and heavier than a sensitive drilling machine. The maximum diameter of the hole size up to 50 mm can be made in this machine. Besides, it is supplied with power feed arrangement, for drilling different types of work, the machine is provided with a number of a spindle speeds and feed.

A round column section of up – right drilling machine is shown in the given figure.

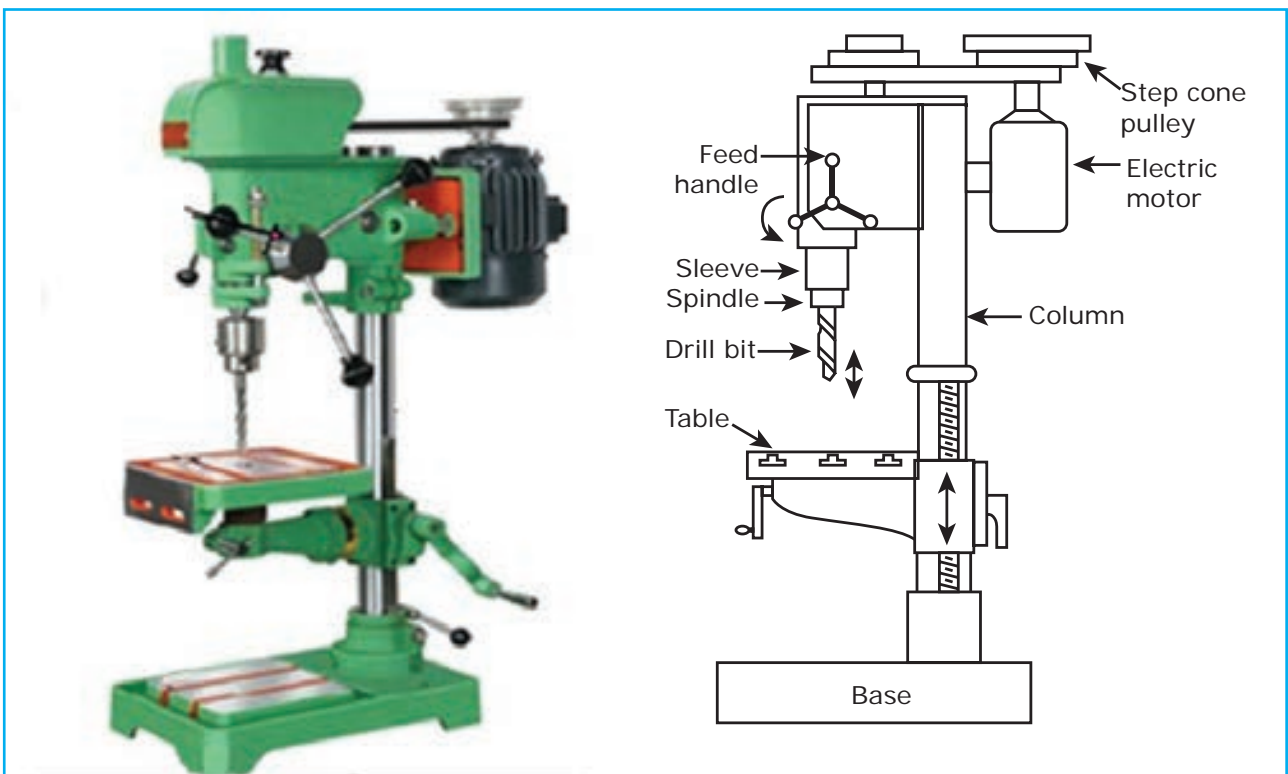

Upright Drilling Machine

There are two different types of upright drilling machines according to the cross-section of the column and they are

- Round column section upright drilling machine.
- Box column section upright drilling machine.

Base

Base is made of cast iron as it can withstand vibrations set by the cutting actions. It is mounted on the floor of the shop by means of bolts and nuts. It is supporting member as it supports column and other parts on it. The top of the base is accurately machined and has T-slots. When large work pieces are to be held, they are directly mounted on the base.

Column

Column stands vertically on the base and supports the work table and all driving mechanisms. It is designed to withstand the vibrations set up due to the cutting action at high speeds.

Work Table

Table is mounted on the column and can be adjusted up and down on it. It is provided with T-slots for work pieces to be mounted directly on it. Table may have the following adjustments.

Vertical adjustment obtained by the rack on the column and a pinion in the table.

Circular adjustment about its own axis.

After the required adjustments are made, the table is clamped in position.

Drill head

The drill head is mounted on the top of the column. It houses the driving and feeding mechanism of the spindle. The spindle can be provided with hand (or) power feed. There are separate hand wheels for quick hand feed and sensitive hand feed. The handle is spring loaded so that the drill spindle is released from the work when the drilling operation is over.

2.8 Radial Drilling machine

The radial drilling machine is intended for drilling and tapping on medium to large and heavy work pieces. It is used in mass production factories and to drill the holes at a diameter of 50mm and above.

A radial drilling machines is illustrated the given figure.

It consists of parts like base, vertical column, radial arm, Drill head. Elevating screw and driving mechanism of the spindle.

Base

The base is a large rectangular casting and mounted on the floor on the shop. Its top surface is accurately finished to support a column at one end and the table at the other end. T-slots are provided on it for clamping the work pieces.

Column

The column is a cylindrical casting which is mounted vertically at one end of the base. It supports the radial arm and allows it to slide up and down on its face. The vertical adjustment of the radial arm is effected by rotating a screw passing through a nut attached to the arm. An

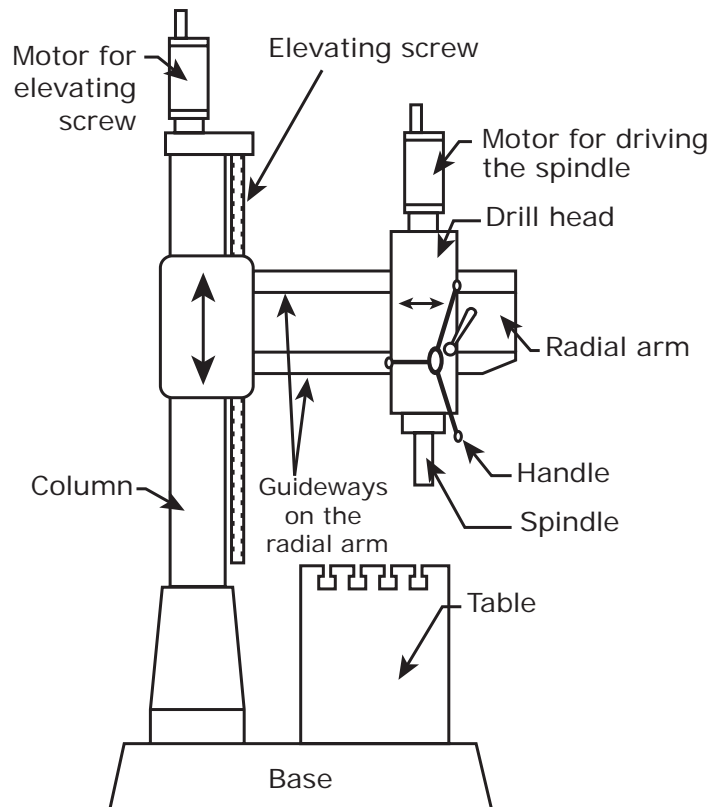

Radial Drilling Machine

electric motor is mounted on the top of the column for rotating the elevating screw.

Radial arm

The radial arm is mounted on the column parallel to the base and can be adjusted vertically. The vertical front surface is accurately machined to provide guide ways for the drill head. The drill head can be adjusted along these guide ways according to the location of the work. The arm may swing at 360° around the column. It can also be moved up and down according to the different heights of the work pieces.

Drill head

The drill head is mounted on the radial arm and houses all mechanism for driving the drill at different speeds and feed.

A motor is mounted on the top of the drill head for this purpose. To adjust the position of drill spindle with respect to the work, the drill head may be made to slide on the guide ways of the arm. The drill head can be clamped in position after the spindle is properly adjusted.

Special Features

- To drill holes at different places of the work pieces without any movement of the work.
- To drill inclined holes on the work piece with the help of tilting the drill head at an angle.
- To make internal threads in a hole by using tapping attachments.



The inventor of Radial drilling machine is Geoffry Reeves of Australia, year 1890.

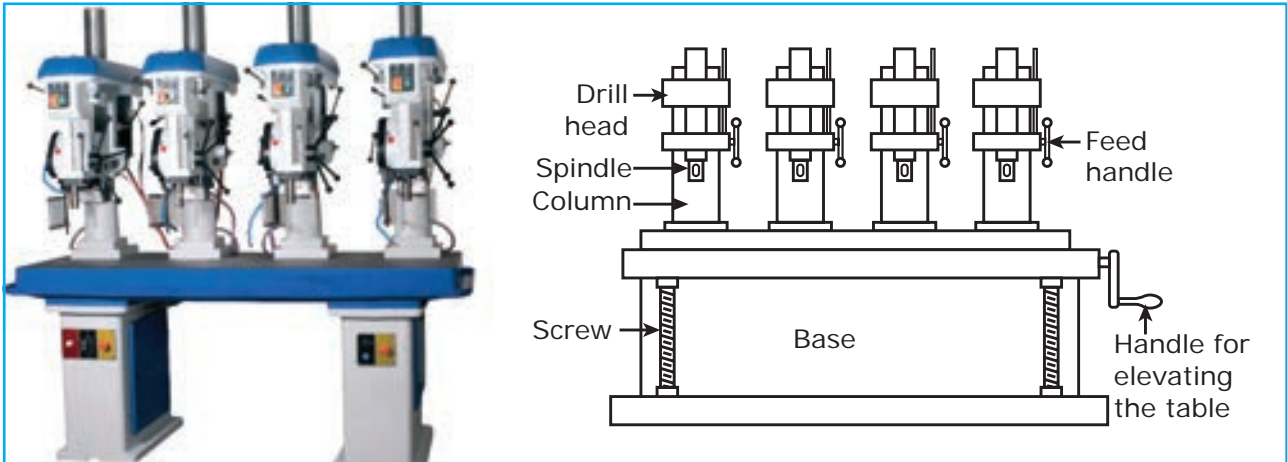

Gang drilling machine

2.9 Gang Drilling Machine

When a number of single spindle drilling machine columns are placed side by side on a common base and a work table, the machine is known as gang drilling machine. The drill heads have separate driving motors. This machine is used for production work.

A series of operations like drilling, reaming, counter boring and tapping may be performed on the work by simply shifting the work from one position to the other on the work table. Each spindle is set with different tools for different operations.

The speed and feed of the spindles are controlled independently.

A gang drilling machine is shown in the given figure.

2.10 Multi – Spindle Drilling Machine

When a machine has two (or) more drill spindles driven by a single motor, is called multi-spindle drilling machine. The drill spindles are connected to the main drive by universal joints.



Multi – spindle Drilling Machine

All the spindles holding the drills are fed into the work at the same time. The distance between the spindles can be altered according to the locations where holes are to be drilled. Drill jigs are used to guide the drills. Feeding motion is usually obtained by raising the work table. A multi spindle drilling machines is shown in the given figure.

2.11 Deep Hole Drilling Machine

A special machine and drills are required to drill deeper holes in barrels of gun, spindles, and connecting rods. The



Deep Hole drilling machine (Horizontal type)

machine designed for this purpose is known as deep hole drilling machine. High cutting speeds and less feed are necessary to drill deep holes. A non-rotating drill is fed slowly into the rotating work at high speeds. Coolant should be used while drilling. There are two different types of deep hole drilling machines.

1. Vertical type
2. Horizontal type



2.12 The size of a Drilling Machine

Drilling Machines are specified according to their type.

1. A portable drilling machine is specified by the maximum diameter of the drill that it can hold.
2. The size of the sensitive and upright drilling machines are specified by the size of the largest work piece that can be centered under the spindle. It is slightly smaller than twice the distance between the face of the column and the axis of the spindle.

3. The size of a radial drilling machine is specified by the diameter of the column and length of the arm, spindle speeds and feeds etc.
4. Gang and multi spindle drilling machines is specified by the number of spindles. Length of the work table and type of feed given to the work.
5. Generally a drilling machine is specified by the maximum diameter of the hole that it can drill in the machine, diameter of table, maximum travel of the spindle, numbers and range of spindle speeds and feeds available.
6. Morse taper number of the drill spindle, floor space required weight of the machine and horse power of the motor.

2.13 Drill spindle Assembly

A drill spindle assembly is illustrated shown in the given figure.

Drill spindle assembly



The spindle is a vertical shaft which holds the drill. A long keyway is cut on the spindle and a sliding key connects it with a bevel gear or a stepped cone pulley. It receives motion from the driving motor. The spindle and the sleeve are connected by a thrust bearing.

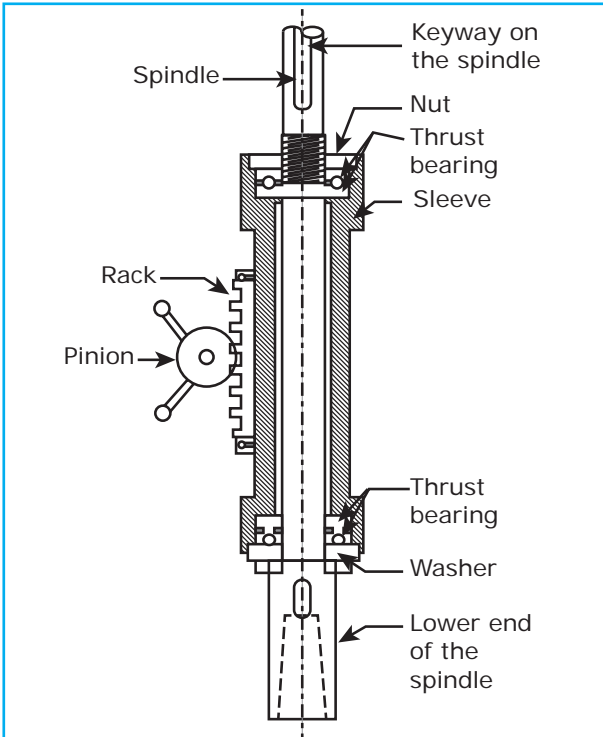

Rack teeth are cut on the outer surface of the sleeve. The sleeve may be moved up and down by rotating a pinion which meshes with the rack. This movement is given to the spindle for providing the required feed. As there is a long keyway on top of the spindle, it is connected to the driving mechanism even during the feed movement.

A morse taper hole is provided at the lower end of the spindle. It is useful in accommodating a taper shank drill. The tang of the drill fits into a slot provided at the end of the taper hole. To remove the drill from the spindle a drift may be pushed through the slot.

The spindle drive is obtained in three methods. They are

1. Step cone pulley drive
2. Step cone pulley with back gear arrangement.
3. Gear box drive.

2.14 Work Holding Devices

The work should be held firmly on the machine table before performing any operations on it. As the drill exerts very high quantity of torque while rotating the work should not be held by hand. If the work pieces are not held by a proper holding device, it will start rotating along with the tool causing injuries to the operator and damage to the machine.

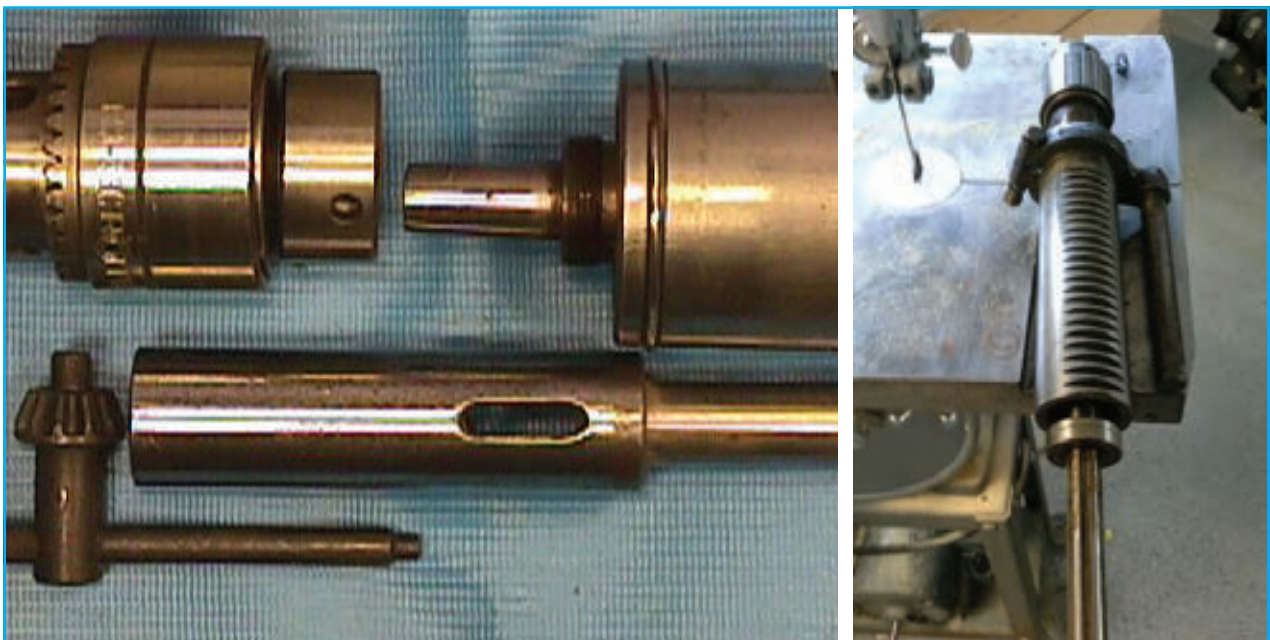

Working Principle of the Spindle

The devices used for holding the work in a drilling machine are

1. Drill vise
2. T-bolt, nut and clamps step block
3. Plain vise
4. V – block
5. Angle plate
6. Drill jigs.

3. Tilting vise
4. Universal vise

Drill vise

Vise is one of the most important devices used for holding work piece on a drilling machine table. The work is clamped in a vise between a fixed jaw and a movable jaw.

Parallel blocks are placed below the work. So that the drill may completely pass through the work without damaging the table. Different types of vises are used for holding different types of work and for performing different operations.

The different types of vises are

1. Plain vise
2. Swivel vise

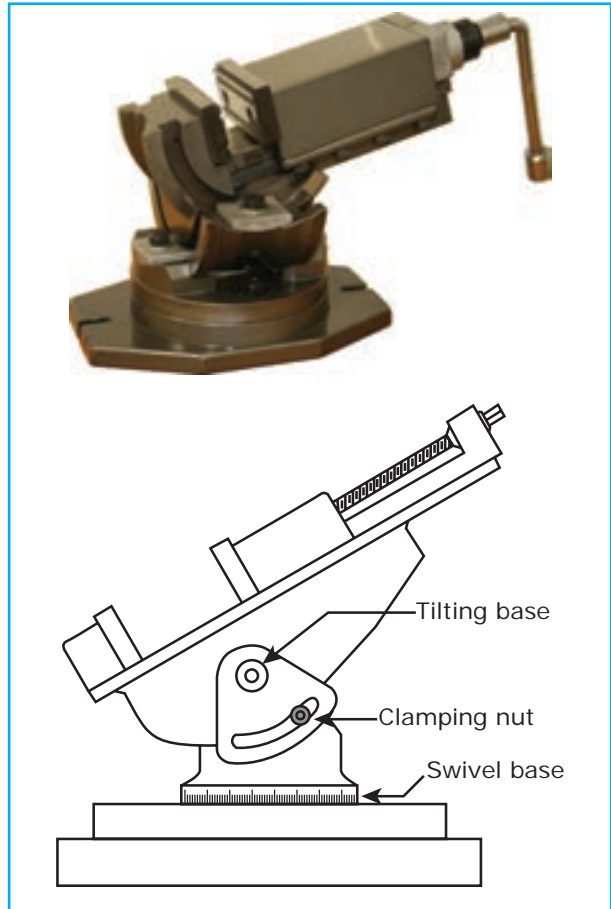

Universal Vise

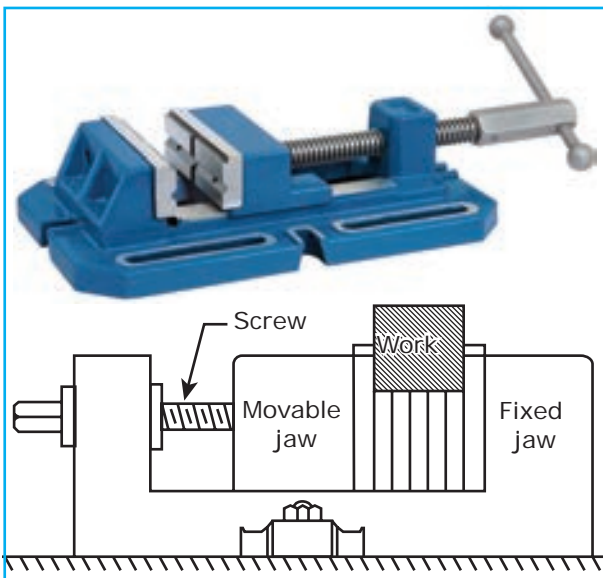

Plain Vise

T-bolts, clamps and step blocks

The work pieces can be held directly on the machine table by means of T-bolts clamps and step blocks. The top of the machine table has T-slots into which T-bolts may be fitted. The bolts of diameter 15 to 20 mm are used. The clamps and step – blocks are made of mild steel. T-bolts pass through a central hole on the clamp. The clamp is made to rest horizontally on the work surface by placing a suitable step block at the end of the work. Different height of the work pieces are held by levelling the clamp on different steps of the step block

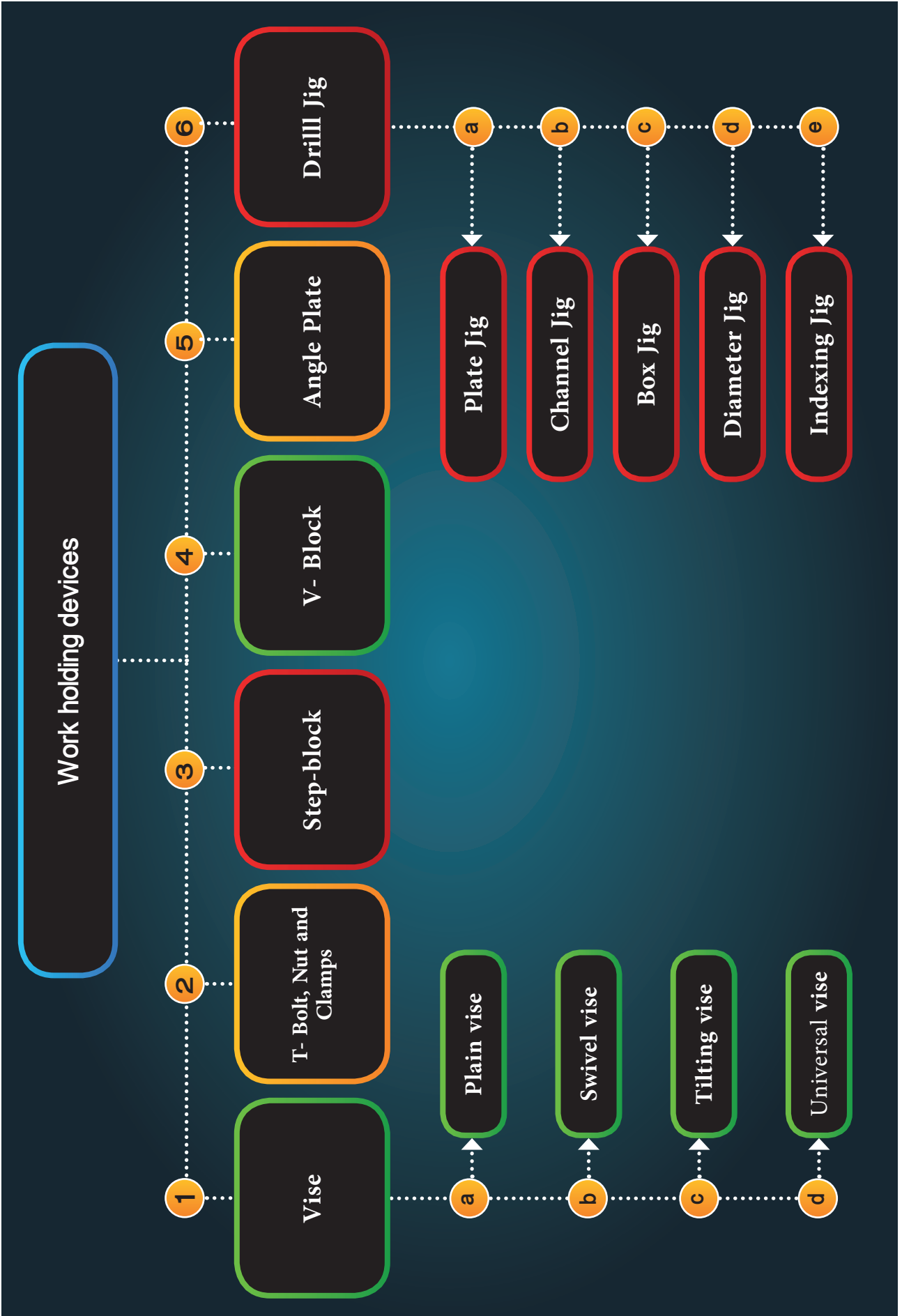

Types of clamps

1. Plain
2. Slot clamp
3. Goose – neck clamp
4. Finger clamp

The following figure shows how to hold the work piece by means of T-slots, clamp and step-block.

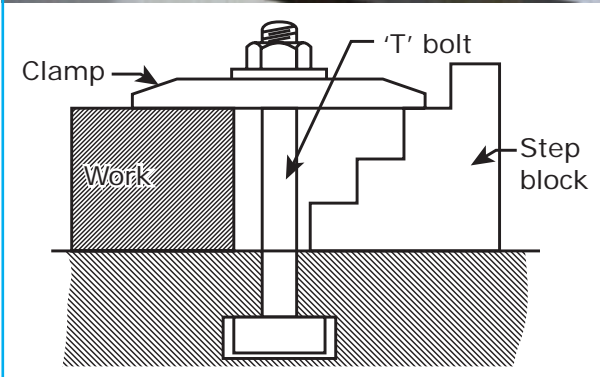
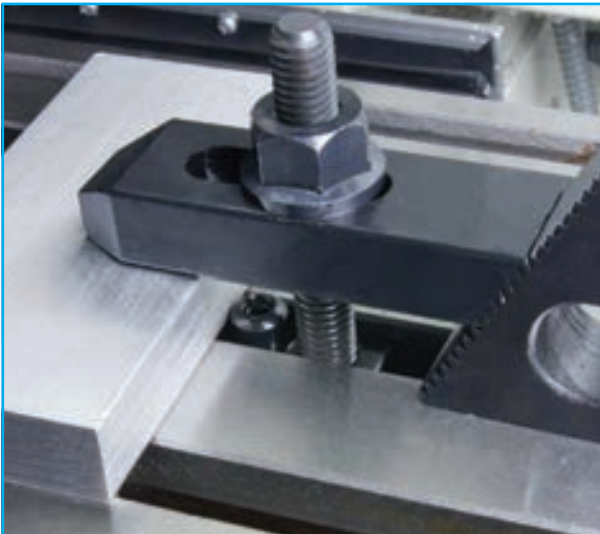

T-bolt and clamp

Step block

It has long steps formation. It is used to hold the work firmly while using the T-bolt and clamps the step block supports the other end of the clamp. Work pieces of different sizes are held by levelling the clamp on different steps of the step block.

V-block

V-block is used for holding cylindrical work pieces. The work may be supported

on two (or) three V-blocks according to the length of the work. The work is held on the V-groove and is clamped by straps and bolts. They are made of cast iron (or) steel and are accurately machined.

The following figure shows the use of a V-blocks.

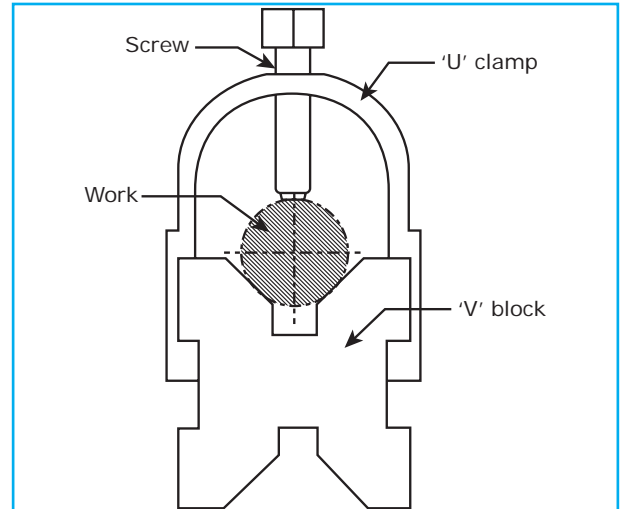

V-block

Angle plate

The angle plates have two faces at right Angle to each other and made of cast iron. All the sides of a angle plate are machined accurately. Slots and holes are provided on both the faces of the angle plate. Work is clamped on one of its faces by means of bolts and nuts. The use of angle plate is shown in figure.

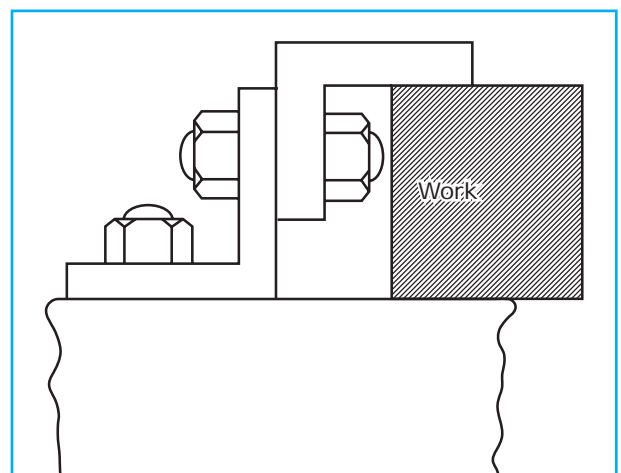

Angle Plate

Drill Jig

Drill jigs are used for holding the work in mass production process. A jig is specially designed to hold the work securely and to guide the tool at any desired position. Holes may be drilled at the same relative positions on each of the identical work pieces.

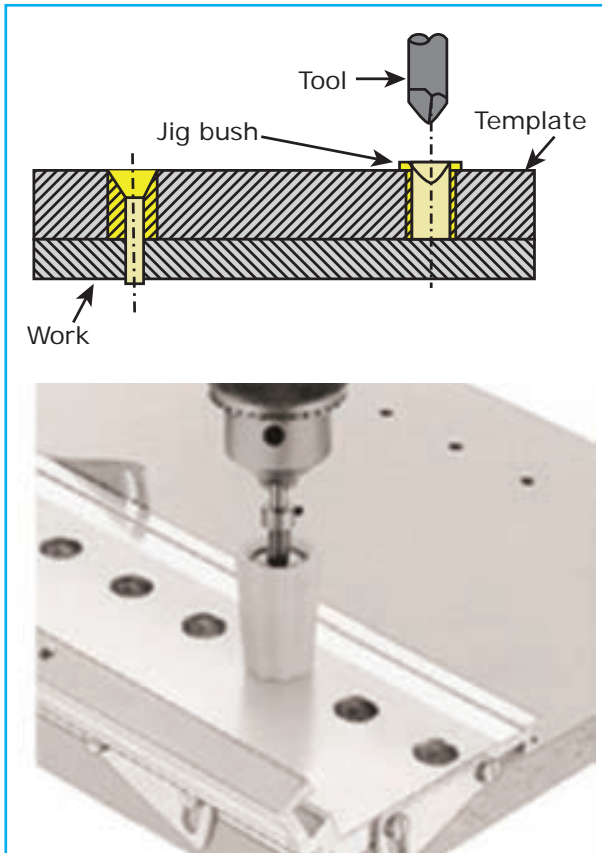

Drill Jig

The work is clamped and removed easily. The cost of making a drill jig is more but a low order of skill is sufficient to work with a drill jig.

The following different types of jigs are used to hold the work pieces in drilling machine.

1. Plate Jig
2. Channel Jig
3. Diameter Jig
4. Box Jig
5. Indexing Jig

2.15 Tools used in a drilling machine

The following tools are used for performing different types of operations in a drilling machine. They are

1. Drill
2. Reamer
3. Counter bore
4. Counter sink
5. Tap

Drill

A drill is a tool used to originate a hole in a solid material. A helical groove known as 'flute' is cut along the length of the drill.



Drill Bit

Different types of drills are,

1. Flat drill
2. Straight fluted drill
3. Twist drill
4. Centre drill

Twist drills are generally used in shop work. They are made of High speed steel (HSS), (or) High Carbon Steel (HCS).

There are two types of drills namely

1. Straight shank twist drill
2. Taper shank twist drill

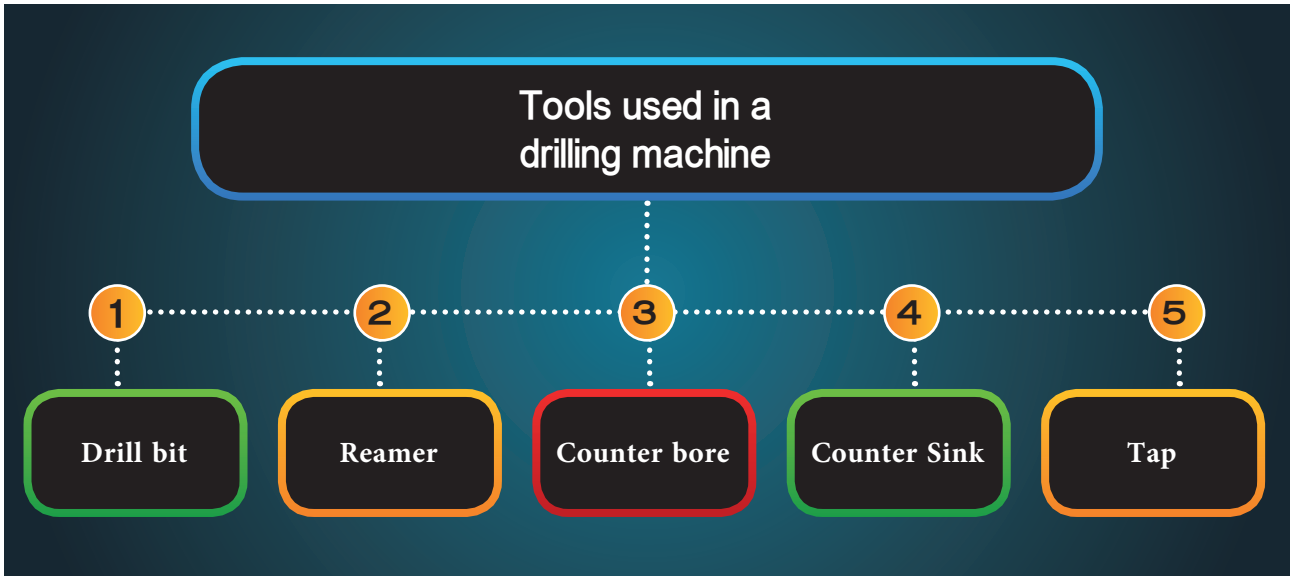

The diameter of the straight shank drill ranges from 2 to 16mm. Taper shanks are provided on drills of larger diameter.



The inventor of Twist drill is “Steve A. Morse” of England, year 1861.

Reamer

The tool used for enlarging and finishing a previously drilled hole is known as a reamer. It is a multi tooth cutter and removes smaller amount of material. It gives a better finish and accurate dimension.



Reamer

Counter bore

A counter bore is a multi tooth cutting tool used for enlarging the top of the previously machined hole. It has three or four cutting teeth.



Counter bore

The flutes on them may be straight or helical. Straight fluted tools are used for machining softer material like brass and aluminium and for short depth of cut. Helical fluted counter bores are used for longer holes.

Counter Sink

A counter sink has cutting edges on its conical surfaces. It has a similar construction of counter bore except for the angle of the cutting edges. The angle of counter sinks will generally be 60° , 82° or 90° . It is used for enlarging the top of the holes conically.



Counter sink

Tap

A tap has threads like a bolt. It has three or four flutes cut across the threads. It can cut threads on the inside of a hole. The flutes on the threads from the cutting edges. It is a multi point cutting tool. It will dig into the walls of the hole as the lower part of the tap is slightly tapered. The shank of the tap is square shaped to enable it to be held by a tap wrench.

Taps are made up of carbon steel (or) high speed steel. Two types of taps are used. They are (i) hand tap and (ii) machine tap

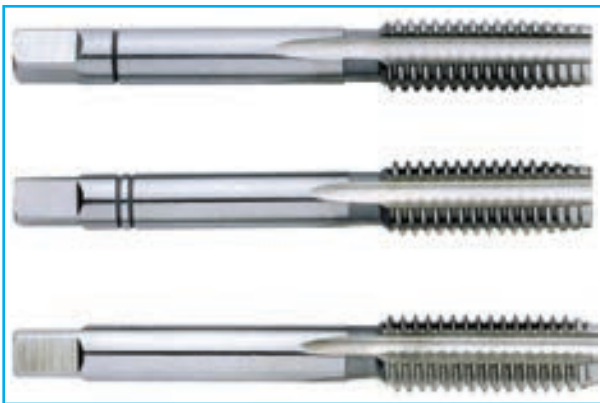

Tap

2.16 Twist drill nomenclature

Twist drill nomenclature is shown in the given figure.

Axis

It is the longitudinal centreline of the drill running through the centres of the tang and the chisel edge.

Body

It is the part of the drill from its extreme point to the commencement of the neck. If present otherwise it is the part extending up to the commencement of the shank.

Helical grooves are cut on the body of the drill.

Shank

It is part of the drill by which it is held and driven. It is found just above the body of the drill. The shank may be straight (or) taper. The shank of the drill can be fitted direct into the spindle (or) by a tool holding device.

Tang

The flattened end of the taper shank is known as tang. It is meant to fit into a slot in the spindle (or) socket. It ensures a positive drive of the drill.

Neck

It is the part of the drill which is diametrically undercut between the body and the shank of the drill. The size of the drill is marked on the neck.

Point

It is the sharpened end of the drill. It is shaped to produce lips. Faces, flanks and chisel edge.

Lip

It is the edge formed by the intersection of flank and face. There are two lips and both of them should be of equal length. Both lips should be at the same angle of inclination with the axis. (59°).

Land

It is the cylindrically ground surface on the leading edges of the drill flutes adjacent to the body clearance surfaces. The alignment of the drill is maintained by the land. The hole is maintained straight and to the right size.

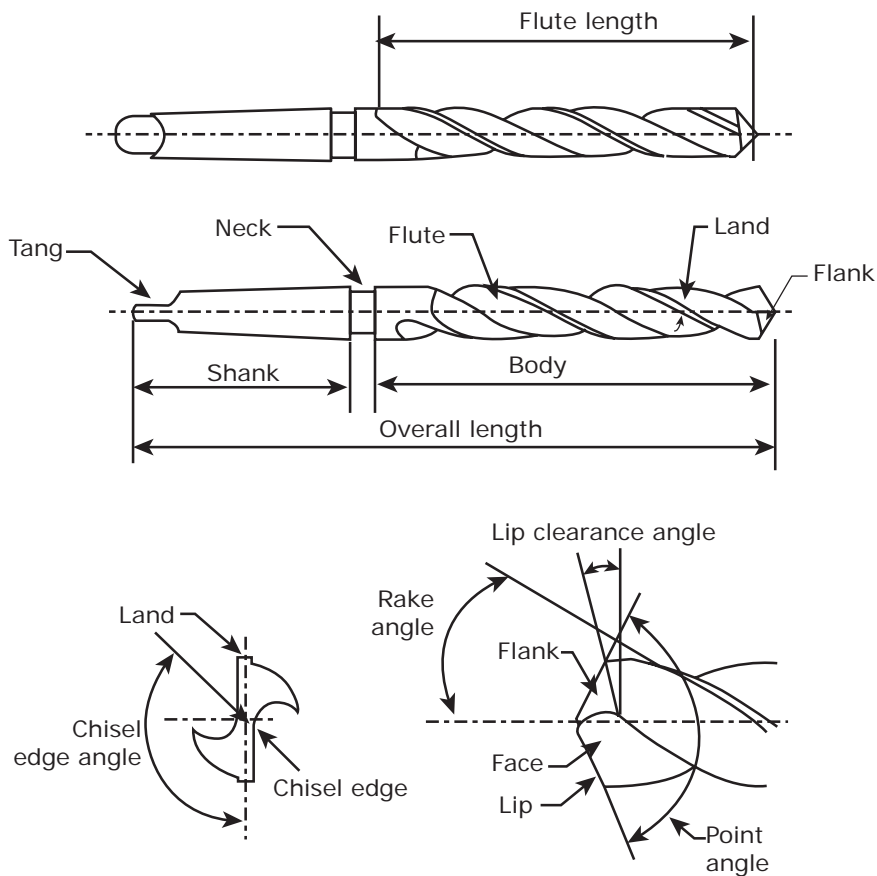

Twist Drill Nomenclature

Flutes

The grooves in the body of the drill are known as flutes.

- Flutes form the cutting edges on the point.
- To allow the chips to escape
- To cause the chips to curl
- To permit the cutting fluid to reach the cutting edges.

Angles

Chisel edge Angle

The obtuse angle included between the chisel edge and the lips as viewed from the end of the drill. Its usual value of

this angle varies from 120° to 135° . Helix angle (or) rake angle.

Point angle

This is the angle included between the two lips projected upon a plane parallel to the drill axis and parallel to the two cutting lips. The usual point angle is 118° when hard alloys are drilled the value of angle increases.

Lip clearance Angle

The angle formed by the flank and a plane at right angle to the drill axis. The angle is normally measured at the periphery of the drill. The lip clearance angle ranges from 12° to 15° .

2.17 Tool holding Devices

Different tools are used for performing different operations. They are fitted into the drill spindle by different methods. They are

1. directly fitting in the spindle
2. a sleeve
3. a socket
4. a drill chuck
5. special attachments
6. Tapping attachments
7. Floating holder.

Directly fitting in the spindle

The following figure shows the drill directly fit into the spindle.

Almost all drilling machines have their spindle bored out to a standard taper (1:20) to receive the taper shank of the tool. While fitting the tool, the shank of the drill (or) any other tool is forced into the tapered hole and the tool is gripped by friction. The tool may be rotated

with the spindle by friction between the tapered surface and the spindle. But to ensure a positive drive the tang of the tool fits into a slot at the end of the taper hole.

The tool may be removed by pressing a tapered wedge known as drift or key into the slotted hole of the spindle.

The drift is made up of hard steel.

Sleeve

The drill spindle is suitable for holding only one size of tool shank. If the shank of the tool is smaller than the taper in the spindle hole a taper sleeve is used. The outside taper of the sleeve conforms to the spindle taper and the inside taper holds the shanks of the smaller size tools. The sleeve has a flattened end or tang which fits into the slot of the spindle. The tang of the tool fits into a slot provided at the end of the taper hole of the sleeve. Different sizes of tool shanks may be held by using different sizes of sleeve. In order to remove the drill from the

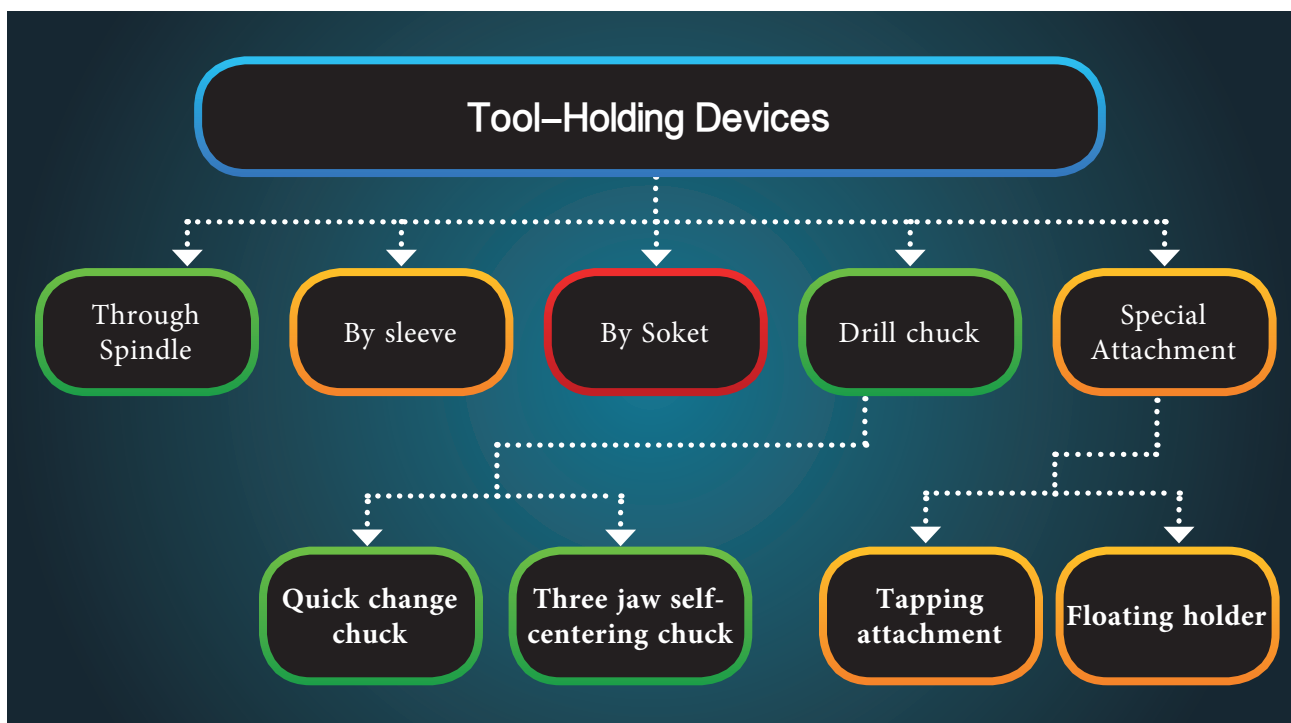

spindle, the drill along with the sleeve is removed with the help of a drift. The drill is then removed from the sleeve by the same method.

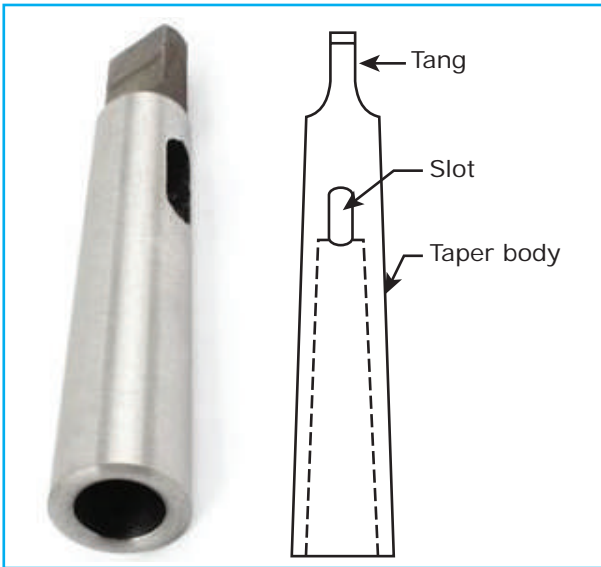

Sleeve

Socket

When the tapered tool shank is larger than the spindle taper, drill sockets are used to hold the tool.



Socket

Drill sockets are much longer in size than the drill sleeves. A socket consists of a solid shanks attached to the end of a cylindrical body. The taper shank of the

socket confirms to the taper of the drill spindle and fits into it. The body of the socket has a tapered hole larger than the drill spindle taper into which the taper shank of any tool may be fitted. The tang of the socket fits into slot of the spindle and the tang of the tool fits slot of the socket.

Drill chuck

This type of chuck is particularly adapted for holding smaller size of drills having straight shanks. The drill chuck has a taper shank at top portion of the chuck, which fits into the taper hole of the spindle. Bevel teeth are cut round the sleeve body which locates at the centre portion of the chuck. At the bottom of the chuck, there are three jaws are fitted at 120° each other. It is used to hold the drill bit.

The jaws are made of spring steel.

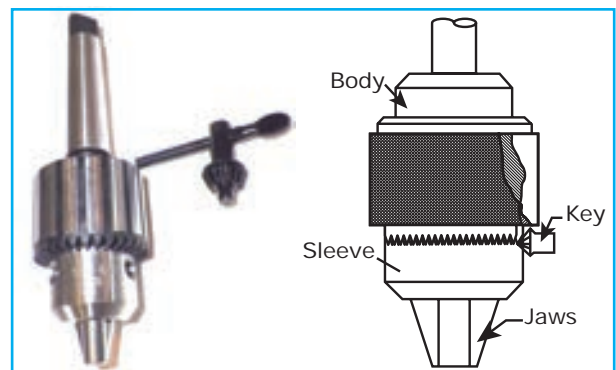

Drill Chuck

There are two types of chucks

1. Quick change chuck
2. Three jaw self-centering chuck

Special Attachment

Tapping attachment

The tapping attachment is used to hold the tool known as tap. It serves as a flexible connection between the spindle and the tap. The taper shank of the attachment

is fitted into the drill spindle. The tap is fitted at the bottom of the attachment. The tap is fed into the specific hole by the spindle. Rotating it in clockwise direction. After the threads are cut, the spindle is released from the hole. The bottom of the attachment rotates in anti-clockwise direction causing no damage to the tapped hole. Tapping attachments are used during production work.

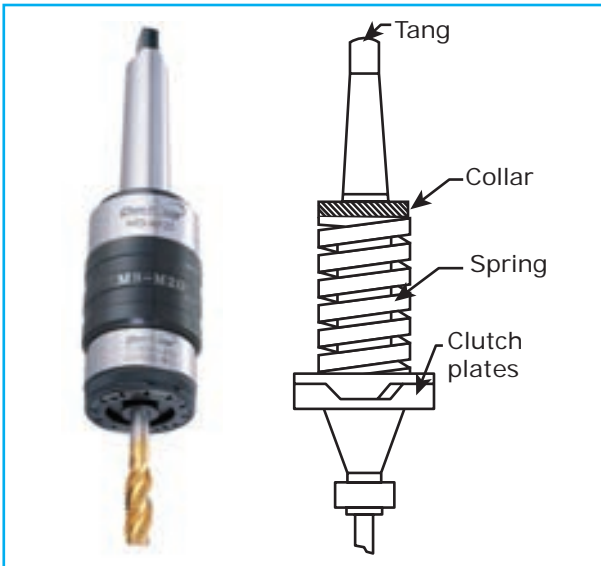

Tapping Attachment

2.18 Drilling Machine Operations

Though drilling is the primary operation performed in a drilling machine, a number of similar operators are also performed on holes using different tools. The different operations that can be performed in a drilling machine are,

1. Drilling
2. Reaming
3. Boring
4. Counter-boring
5. Counter-sinking
6. Spot-facing
7. Tapping
8. Trepanning

Drilling

Drilling is the operation of producing a new cylindrical hole of required diameter and depth by removing metal by the rotating edge of a cutting tool called drill. Drilling is one of the simplest methods of producing a hole. Drilling does not produce an accurate hole in a work piece. The internal surface of the hole generated by drilling becomes rough and the hole is always slightly oversize due to vibration of the spindle and the drill. A 12 mm drill bit may produce a hole of size 12.125 mm.

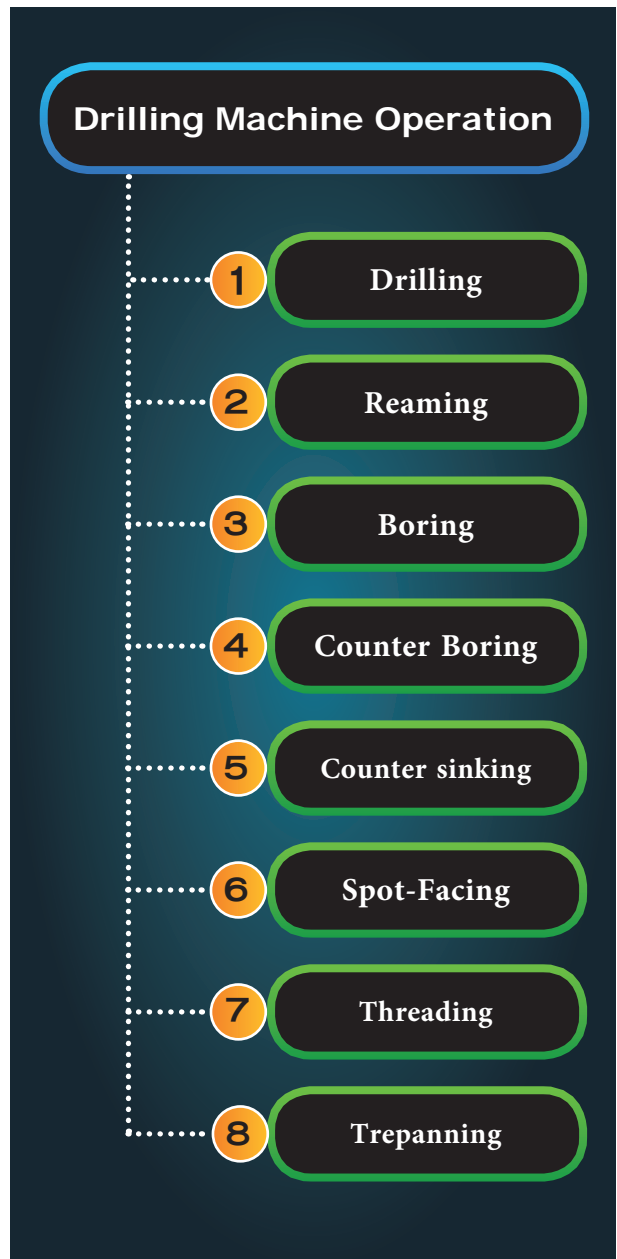

Before making a new hole by using on the work piece, first draw two lines at right angle to each other. Then a centre punch is used to make a centre on the work piece accurately.

The figure shows the drilling operation

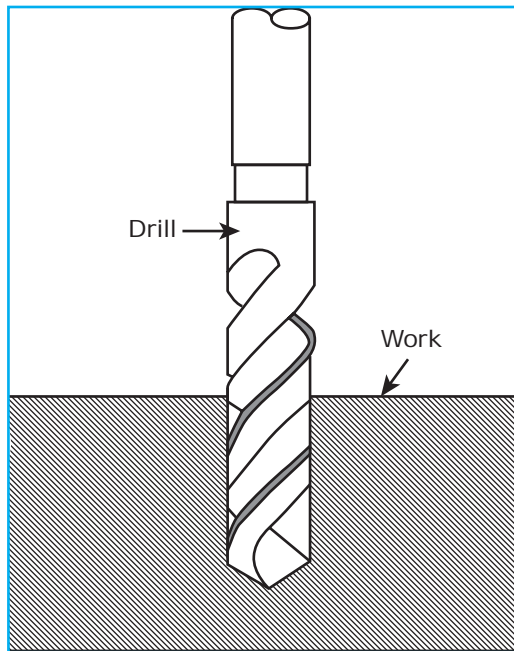

Drilling

Reaming

The size of hole made by drilling may not be accurate and the internal surface may not smooth. Reaming is an accurate way of

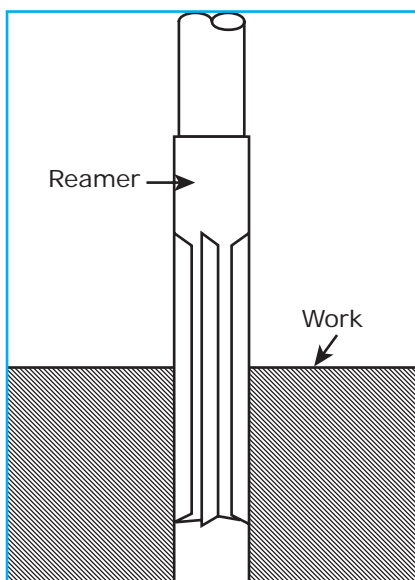

Reaming

sizing and finishing a hole which has been previously drilled by a multi – point cutting tool known as reamer. The surface obtained by reaming will be smoother and the size accurate. The speed of the spindle is made half that of drilling. Reaming removes very small amount of metal (approximately 0.375mm). In order to finish a hole and bring it to the accurate size, the hole is drilled slightly undersize. The figure shows reaming operation.

Boring

Boring is the operation enlarging the diameter of the hole previously made. It is done for the following reasons.

To enlarge a hole by means of an adjustable cutting tool. This is done when a suitable sized drill is not available (or) the hole diameter is so large that is cannot be ordinarily drilled.

1. To finish a hole accurately and bring it to the required size.
2. To machine the internal surface of the hole already produced in casting.
3. To correct out of roundness of the hole.
4. To correct the location of the hole as the boring tool follows independent path with respect to the hole.

Boring tool is a tool with only one cutting edge. The tool is held in a boring bar which has a taper shank to fit into the spindle (or) a socket. For perfectly finishing a hole, the job is drilled undersize slightly. Boring operation in some precise drilling machine is performed to enlarge the holes to an accuracy of 0.00125mm. The spindle speed during the boring operation should be adjusted to be lesser than that of reaming.

The figure illustrates the boring operation.

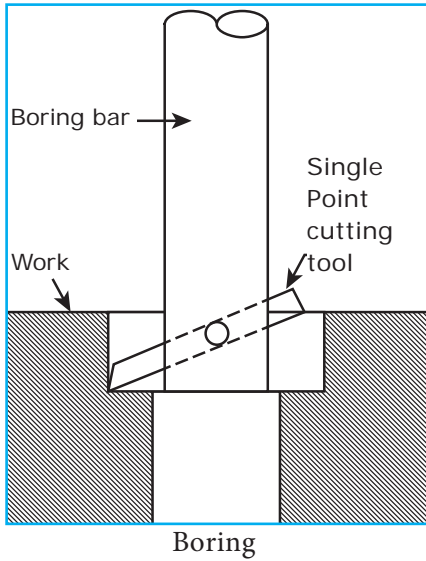

Counter Sinking

Counter sinking is the operation of making a cone shaped enlargement at the end of the hole. The included angle of the conical surface may be in the range of 60° 82° (or) 90° . It is used to provide recess for a flat headed screw or a counter sunk rivet fitted into the hole. The tool used for counter sinking is known as a counter sink. It has multiple cutting edges on its conical surface. The cutting speed for counter sinking is 25% lesser than that of drilling.

The figure illustrates counter sinking operation.

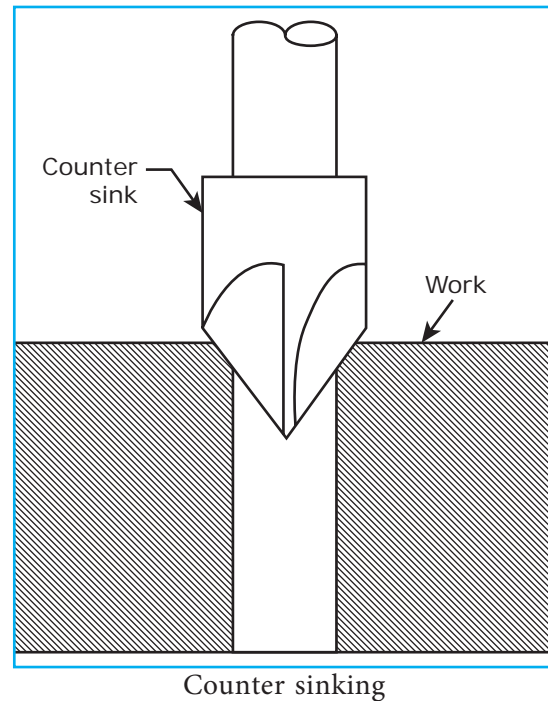

Counter boring

Counter boring is the operation of enlarging the end of the hole cylindrically. The enlarged hole forms a square shoulder with the original hole. This is necessary in some cases to accommodate the heads of bolts, studs and pins. The tool used for counter boring is known as counter bore.

The counter bores are made with cutting edges which may be straight (or) spiral. The cutting speed for counter boring is at least 25% lesser than that of drilling.

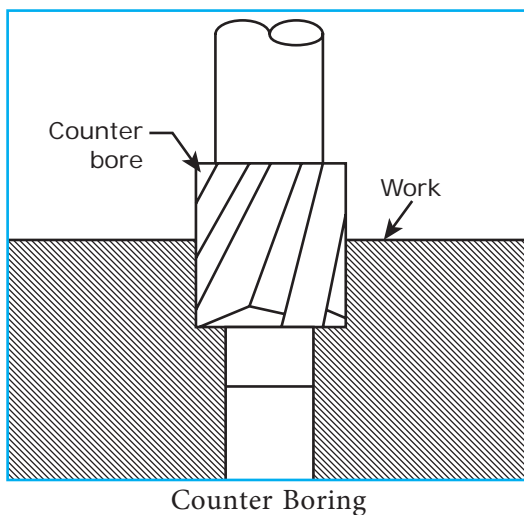

Spot facing

Spot facing is the operation of smoothing and squaring the surface around a hole. It is done to provide proper seating for a nut (or) the head of screw. A counter bore or a special spot facing tool may be employed for this purpose.

The following figure illustrates spot facing operation.

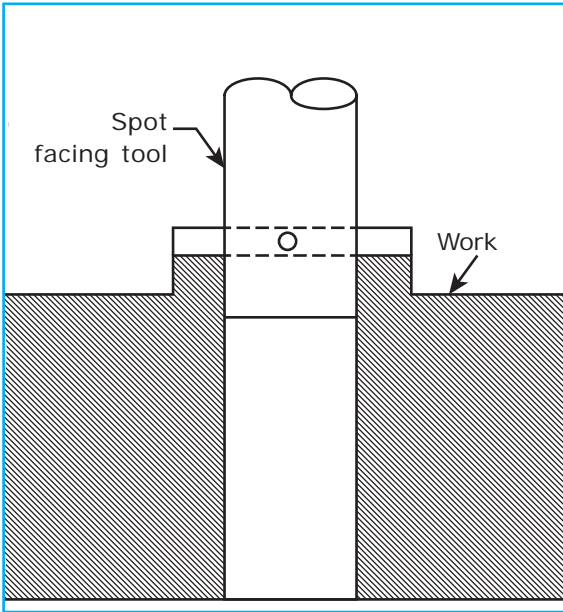

Spot Facing

Tapping

Tapping is the operation of cutting internal threads by means of a cutting tool called “Tap”. Tapping in a drilling machine may be performed by hand (or) by power. When the tap is screwed into the hole. It removes metal and cuts internal threads which fit into external threads of the same size.

The following figure illustrates tapping operation.

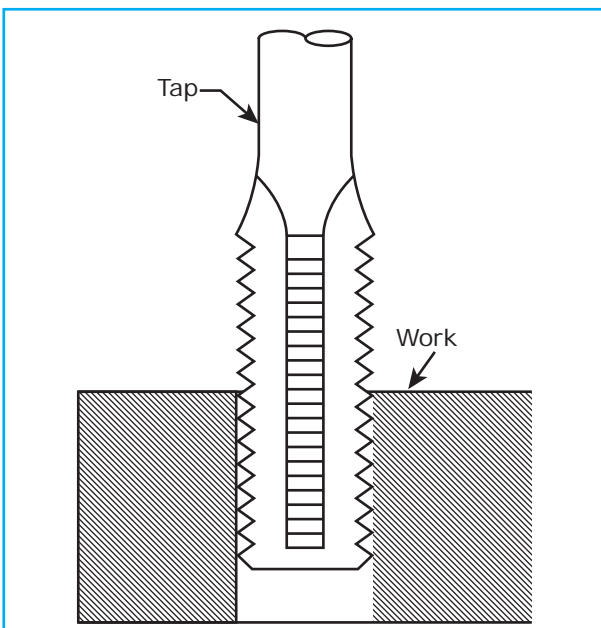

Tapping

Calculation of the Tap drill size

Tap drill size may be derived from the following formula.

$$\text{Tap drill size 'D'} = T - 2d$$

Where ‘T’ is the outer diameter of tap to be used. And ‘d’ is depth of the thread.

Tap drill size can also be calculated the following formula.

$$D = 0.8T$$

Example:

Calculate the tap drill size. When outside diameter of the tap is 10mm the pitch of the thread is 1.5 mm and depth is 0.61mm.

Trepanning

Trepanning is the operation of producing a hole in sheet metal by removing metal along the circumference of a hollow cutting tool. Trepanning operation is performed for producing large holes. Fewer chips are removed and much of the material is saved while the hole is produced. The tool may be operated at higher speeds. The speed depends upon the diameter of the hole to be made. The tool resembles a hollow tube having cutting edges at one end and a solid shank at the other to fit into the drill spindle.

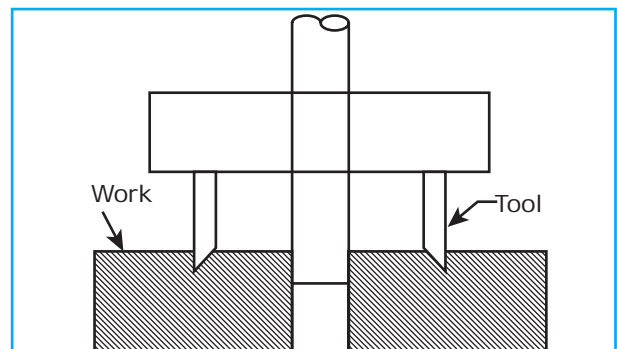

Trepanning

The other operations can be performed in drilling machine are lapping and grinding.

2.19 Cutting speed, feed and depth of cut

Cutting speed

Speed in general refers to the distance a point moves in a particular period of time. The cutting speed in a drilling operation refers to the peripheral speed of a point on the cutting edge of the drill. It is usually expressed in meters per minute. The cutting speed (v) may be calculated as.

$$\text{Cutting speed (c.s) } V = \frac{\pi dn}{1000} \text{ m/min.}$$

Where 'd' is the diameter of the drill in mm,

'n' is the speed of the spindle in rpm and

$$\pi = \frac{22}{7} \text{ (or) } 3.14.$$

Example:

A drill of diameter 20mm makes a hole on a steel part at a cutting speed of 25m/min.

Find out the spindle speed.

$$\text{Cutting speed (c.s) } V = \frac{\pi dn}{1000} \text{ m/min}$$

$$25 = \pi \times 20 \times n / 1000$$

$$n = 25 \times 1000 / \pi \times 20 = 398 \text{ rpm.}$$

Spindle speed 'n' = 398 rpm.

Feed

The feed of a drill is the distance. The drill moves into the work at each revolution of the spindle. It is expressed in millimetres. The feed may also be expressed as feed per minute. The feed per minute may be defined as the axial distance moved by the drill into the work per minute. Feed depends upon factors like the material to

be drilled. The rigidity of the machine, power, depth of the hole and the type of finish required.

Depth of cut

The depth of cut in drilling is equal to one half of the drill diameter. If 'd' is the diameter of the drill. The depth of cut (t) $t = d/2$ mm.

2.20 Safety precautions

It is necessary that no damage is done to the operator, the machine parts and the cutting tool. To ensure this the following points are to be remembered.

1. The work should not be held by hand in any case.
2. Proper work holding device should be used to hold the work. If the work is not held properly. The work tends to rotate along with the drill causing damage to the operator, the machine tool and the cutting tool.
3. The shank of the drill and taper hole of the spindle should be cleaned before it is fitted into the spindle.
4. The shank of the drill should confirm with the spindle hole.
5. Cutting speed, feed and depth of cut should be selected according to the prescribed range.
6. Care should be taken to ensure whether the belt and gears are connected properly.
7. Proper safety plates should be installed around rotating parts like belt, drive and gears.
8. The operator should wear safety goggles while operating the drilling machine.
9. The machine should be disconnected from electric terminals when repairs are under taken. In general we should ensure the proper functioning of the machine tools.

ACTIVITIES

1. To make an arrangement the students to visit the workshop, polytechnic and engineering colleges, to observe the various operations performed by drilling machines.
2. To give more exercises to the students, to make holes by using drilling machine and Lathe machine in school practical Laboratory.

Questions

Part I

Choose the correct option

1 Mark

1. The inventor of first electric drilling machine is.
 - a) Henry Maudslay
 - b) Arthur James Arnot
 - c) Eli whitney
 - d) James Nasmith
2. The drilling machine used in constructional work is,
 - a) Bench drilling machine
 - b) Portable drilling machine
 - c) Gang drilling machine
 - d) Multi spindle drilling machine
3. Counter – bore is a
 - a) Multi – point cutting tool
 - b) Single point cutting tool
 - c) Parting tool
 - d) Saw teeth cutting tool
4. The size of the hole can be drilled in up right drilling machine is
 - a) up to 10mm
 - b) up to 12 mm
 - c) up to 50mm
 - d) up to 70 mm



5. The lip clearance angle of a drill is,
 - a) 59°
 - b) 118°
 - c) 12° to 15°
 - d) 135°
6. The name of the groove in drill is,
 - a) V-type groove
 - b) U-type groove
 - c) Flute
 - d) Straight type groove

Part II

Answer the following questions in one or two sentences.

3 Marks

7. Define – “Drilling”
8. Mention any four types of drilling machine
9. What are the different types of drills?
10. What are the uses of “Flute” in a drill?
11. Mention any four types of tool – holding devices in drilling machine.
12. State any two differences between the process of reaming and boring.
13. In which situation boring is needed?
14. What is the need of spot facing?
15. Define “Cutting speed” of a drilling machine.

Part III

Answer the following questions in about a page

5 Marks

16. Draw and explain a bench drilling machine.
17. How is the size of a drilling machine specified?
18. Explain any two types of drill holding devices.
19. Mention the differences between Gang drilling machine and multi spindle drilling machine.

Part IV

Answer the following questions in detail.

10 Marks

20. Draw a neat diagram of a upright drilling machine and explain.
21. Explain the working principle of a drill spindle with a diagram.
22. Explain the construction of a radial drilling machine.
23. Explain any two work – holding devices used in a drilling machine.
24. Sketch the Nomenclature of a twist drill with a diagram.
25. Explain any two operations performed in a drilling machine.

Shaping Machine



Learning Objectives

- To understand the students about important parts of shaping machine, application of machine mechanism, various types of operations performed in the machine.



Uruvu kandu ellaamai vaendum urul
Perundhaerkku achchaani annar udaiththu. –Kural 667

Despite not men of modest bearing, look not at form, but what men are, for some there live, high functions sharing, like linch-pin of the mighty car.

CONTENTS

- | | |
|---------------------------------------|--|
| 3.1 Introduction | 3.10 Swivel tool head |
| 3.2 Process of machining | 3.11 Work-Holding devices |
| 3.3 Main parts of the shaping machine | 3.12 Types of shaper tools |
| 3.4 Types of shaping machine | 3.13 Setting of shaper table, vice and Tool head |
| 3.5 Quick return mechanism | 3.14 Types of shaping operations |
| 3.6 The size of a shaper | 3.15 Special operations |
| 3.7 Adjusting the length of stroke | 3.16 Cutting speed, depth of cut and feed |
| 3.8 Method of table movement | 3.17 Coolant |
| 3.9 Pawl and Ratchet mechanism | 3.18 Safety precautions |



Shaping machine was designed by James Nasmyth, an Englishman in the year 1836. He designed it to produce flat surface. After it was designed by him to produce various surfaces like horizontal, vertical, inclined, concave and convex surfaces.



James Nasmyth

3.1 Introduction

Shaping is a process of machining a flat surface which may be horizontal, vertical, inclined, concave or convex using a reciprocating single point tool. A shaping machine is a reciprocating type of machine tool. James Nasmyth, an Englishman designed a shaping machine to produce flat surfaces in the year 1836.

3.2 Process of Machining

The work is held firmly on the table and the ram is allowed to reciprocate over it. A single point cutting tool is attached to the ram. When the ram moves horizontally in the forward direction, the tool removes metal from the work. On the return stroke, metal is not removed. The ram moves at

a slow speed during forward stroke. But during the forward and return stroke remain the same, the time taken by the return stroke is less as it is faster. It is possible by 'Quick return mechanism'.

In a shaping machine, a flat horizontal surface is machined by moving the work mounted on the table in a cross direction to the tool movement. When vertical surfaces are machined, the feed is given to the tool.

When an inclined surface is machined, the vertical slide of the toolhead is swiveled to the required angle and the feed is given to the tool by rotating the downfeed hand wheel.

The method of machining in a shaper is illustrated in Figure.

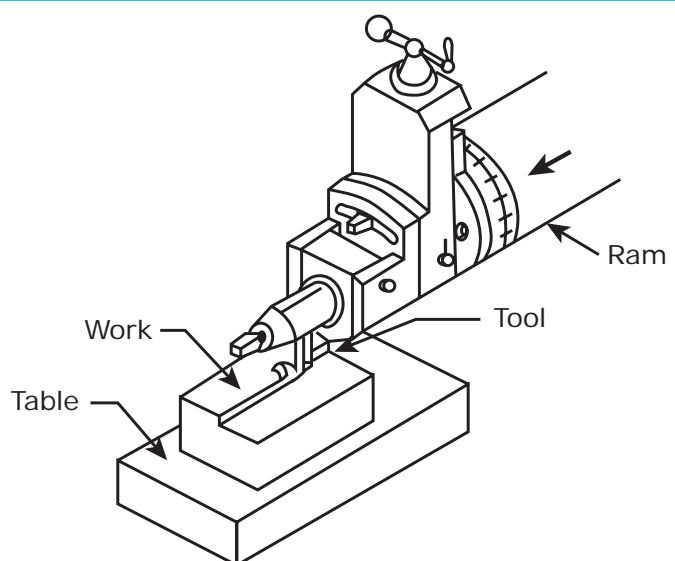

Machining process

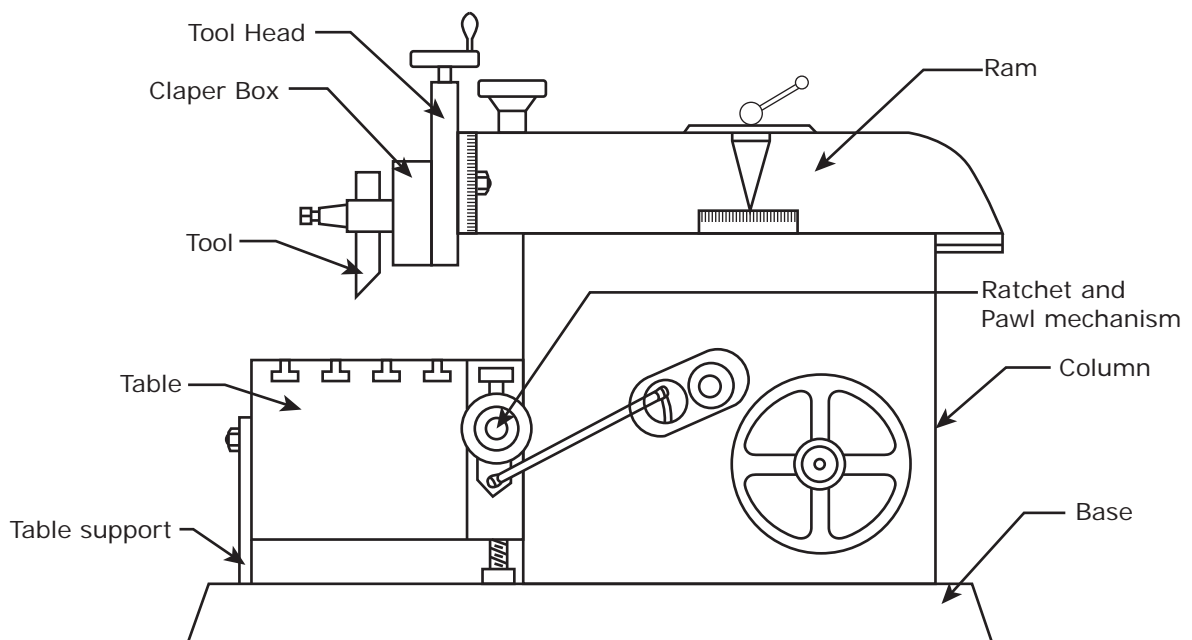

Shaping Machine

3.3 Main parts of shaping machine

Base

The base is hollow and is made of cast iron. It provides the necessary support for all the other parts of the machine. It is rigidly bolted to the floor of the workshop.



Column

It is a box like casting mounted vertically on top of the base. Two accurate guideways are machined on the top of the column. The ram reciprocates on these guideways. The front face of the column is provided with two vertical guideways. They act as guideways for the crossrail. Crossrail moves vertically along these guideways. The column encloses the ram reciprocating mechanism and the mechanism for strokelength adjustment.

Cross rail

It is mounted on the front vertical guideways of the column. The table may be raised or lowered by adjusting the cross rail vertically. A horizontal cross feedscrew is fitted within the crossrail.

The construction of a shaping machine is shown

Saddle

The saddle is mounted on the cross rail. It holds the table rigidity on its top. The saddle can be moved in crosswise direction, by holding the crossfeed screw by hand or power.

Table

It is an important part useful in holding the work firmly on it. It is mounted on the saddle which is located above the crossrail. The top and sides of the table are accurately machined and have T-slots. Workpieces are held on the table with the help of shaper vise, clamps and straps.

Ram

Ram supports the toolhead on its front. It reciprocates on the accurately machined guideways on the top of the column. It is connected to the reciprocating mechanism placed inside the column. The position of ram reciprocation may be adjusted according to the location of the work on the table.

Toolhead

The toolhead is fitted on the face of the ram and hold the tool rigidly. It provides vertical and angular feed movement of the tool. The swivel toolhead can be positioned at any required angle and the vertical slide can be moved vertically or at any desired angle to machine vertical or inclined surfaces.

3.4 Types of shaping machine

The shaping machines are classified as follows

1. According to the type of driving mechanism
 - a. Crank type
 - b. Hydraulic type
 - c. Geared type
2. According to the design of the table
 - a. Plain shaper
 - b. Heavy duty shaper

- c. Standard shaper
- d. Universal shaper
- 3. According to the position and travel of ram
 - a. Horizontal shaper
 - b. Vertical shaper
- 4. According to the type of cutting
 - a. Push cut shaper
 - b. Draw cut shaper

Crank type shaper

Crank and slotted link mechanism of a crank type shaper converts the rotation of an electric motor into reciprocating movement of the ram. Though the lengths of both the forward and return strokes are equal, the ram travels at a faster speed during return stroke. This quick return is incorporated in almost all types of shaper.

Hydraulic shaper

The ram of a hydraulic shaper is connected to a piston. Oil at high pressure is pumped to the cylinder of the hydraulic system. As the oil pushes the piston, the ram reciprocates. Hydraulic shapers are high power machines and are used for heavy duty work.

Universal shaper

The universal shaper has a special type of table which can be swiveled and positioned at any angle about a horizontal axis. Apart from the cross and vertical travel, the table of a universal shaper can be swiveled to any angle to machine inclined surfaces. In the process, the position of the work in the table need not be changed. These machines are utilized in precision workshops.

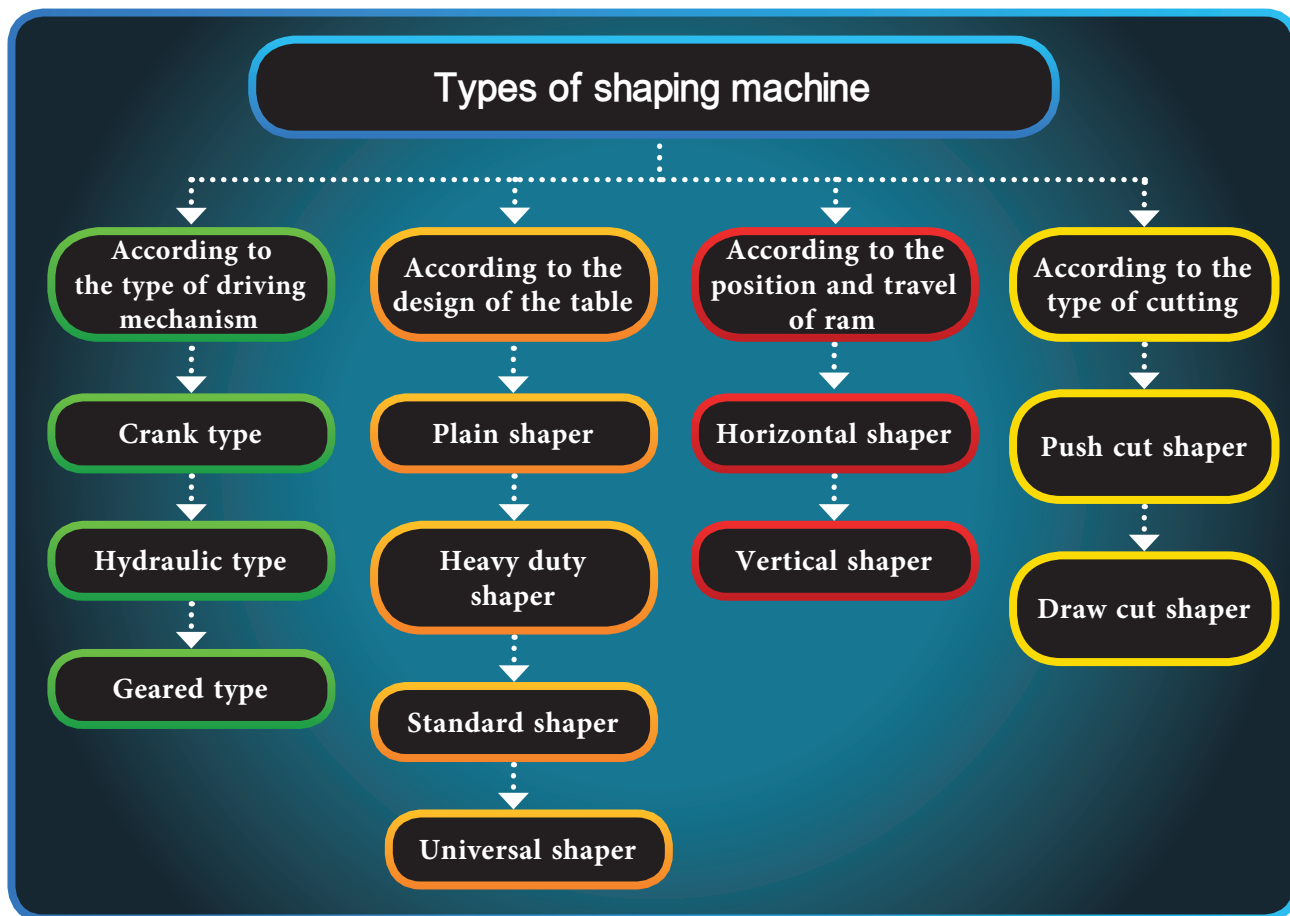

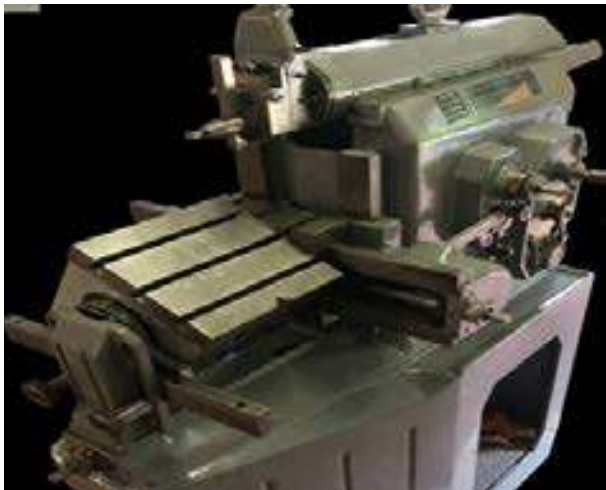

Universal shaper

3.5 Quick return mechanism

The ram moves at a comparatively slower speed during the forward cutting stroke. During the return stroke, the mechanism is so designed to make the tool move at a faster rate to reduce the idle return time. This mechanism is known as quick return mechanism.



At the ram moves at a faster rate during stroke, the time taken becomes less. The total machining time decreases

and the rate of production increases. The following mechanisms are used for quick return of the ram.

1. Crank and slotted link mechanism
2. Hydraulic mechanism
3. Whitworth mechanism

Crank and slotted link mechanism

An electrical motor runs the driving pinion(S) at a uniform speed. This pinion makes the bull gear (M) to rotate at a uniform speed. Bull gear is a large gear fitted inside the column. The point 'O' is the centre of the bull gear. A slotted link having a long slot along its length is pivoted about the point 'K'. A sliding block 'N' is fitted inside the slot and slides along the length of the slotted link. 'P' is the crank pin and 'OP' can be considered as a crank.

Figure shows the crank & slotted link mechanism.

When the bull gear rotates, the sliding block also rotates in the crank pin circle. This arrangement provides a rocking movement to the rocker arm. As

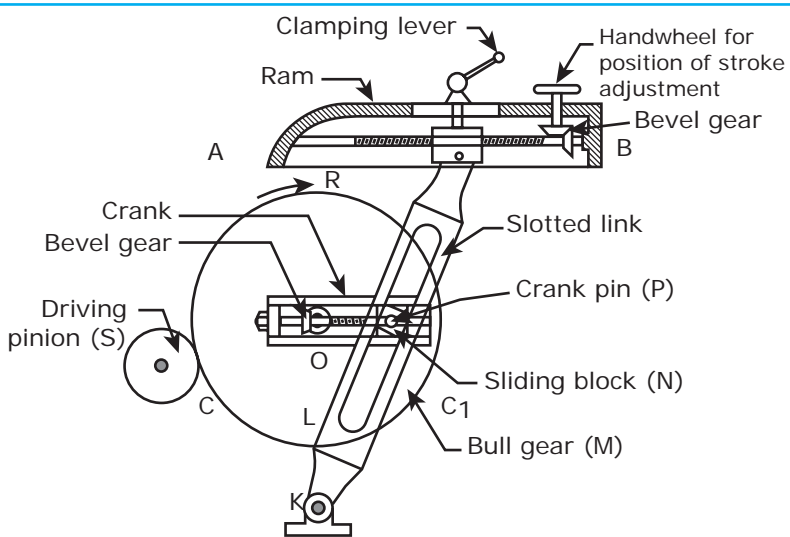
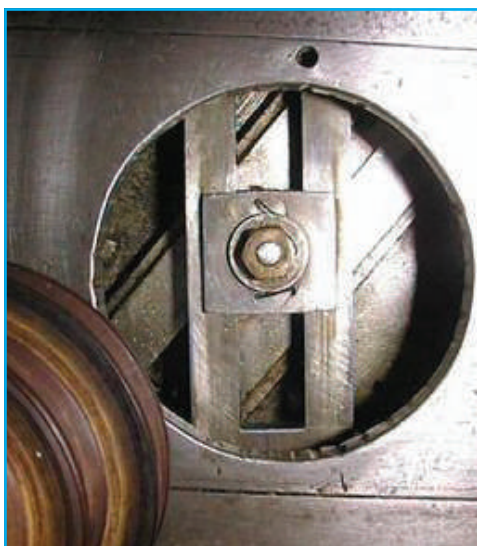

Crank and Slotted link Mechanism

the top of the slotted link is connected to the ram, the ram reciprocates horizontally. So, bull gear rotation is converted into the reciprocating movement of the ram.

Quick return mechanism

As shown in the diagram, 'KA' indicates the starting point of the forward cutting stroke and 'KB' the end of the cutting stroke. The rotation of the crank 'OP' in clockwise direction through the angle CRC_1 refers to the forward cutting stroke. The rotation of the crank in the same direction through the angle C_1LC refers to the return stroke. As the angle C_1LC is smaller than the angle CRC_1 , the time taken for the return stroke is less than that of forward stroke. So, it is evident that the speed at which the ram travels during return stroke is more.

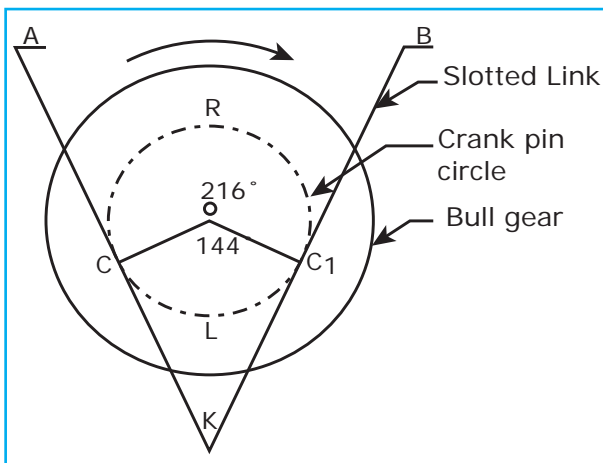

Quick Return Mechanism

Time taken for forward cutting stroke = angle CRC_1

Time taken for the idle return stroke = angle C_1LC
 $= 216^\circ / 144^\circ$
 $= 3 / 2,$

In some machines this ratio can be set as 7/5.

The strokelength of a ram is the distance the ram moves forward or backward. It depends upon the distance between the centre of the bull gear and the centre of the sliding block. It is adjusted according to the length of the work.

3.6 The size of a shaper

The size of a shaper is determined by the maximum length of stroke it can make. Shapers with maximum strokelength of 175 mm to 900 mm are available. Machines with maximum strokelength of 300 mm 450 mm and 600 mm are used widely.

To specify the machine further, the following points are to be provided.

1. The type of drive
 - a. Individual motor
 - b. Belt driven
2. The method of obtaining different speeds
 - a. Gear box
 - b. Step cone pulley
3. Horse power of the motor
4. Cutting to return stroke ratio
5. Number and range of speed arrangement
6. The type of the table.

3.7 Adjusting the length of stroke

The length of the stroke is calculated to be nearly 30 mm longer than the work. The position of stroke is so adjusted that the tool starts to move from a distance of 25 mm before the beginning of the cut and continues to move 5 mm after the end of the cut. For example as shown in Figure, the length of the work is 100 mm. The

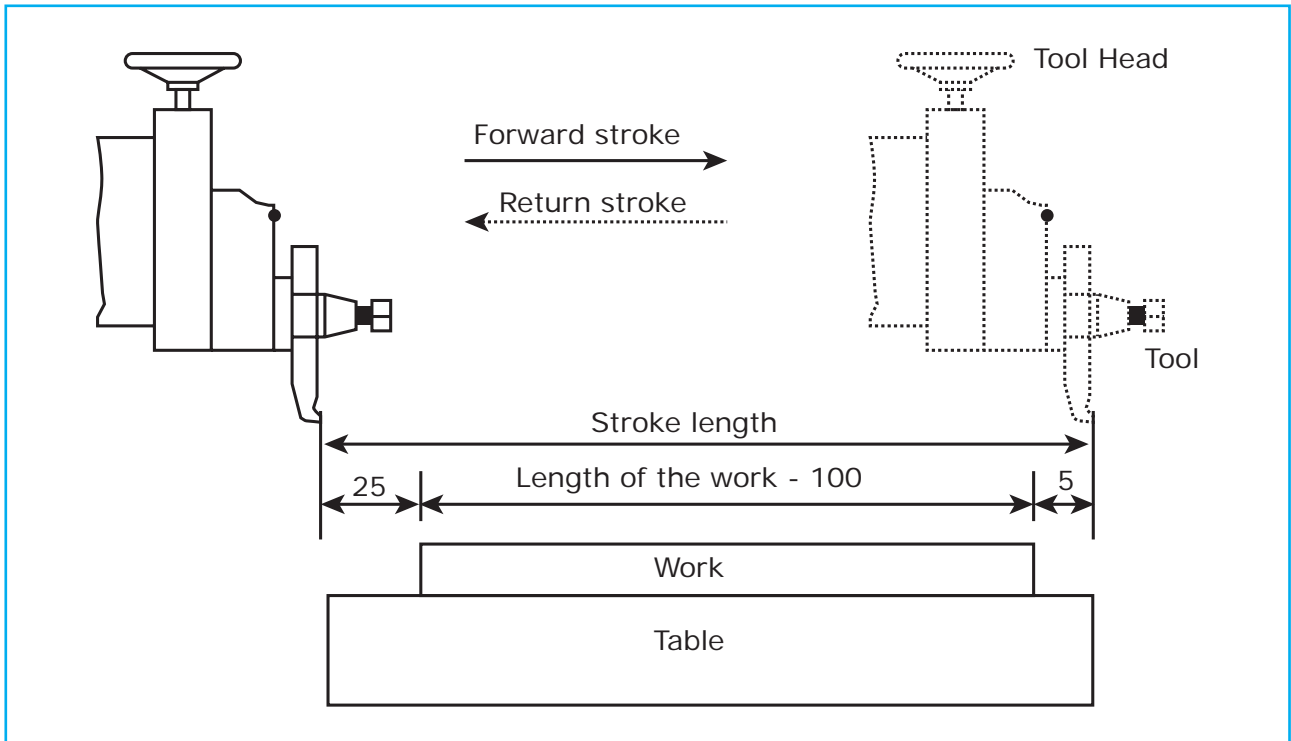

Ram Position

stroke length of the ram is calculated to be 130 mm. ($25+100+5$). Fig illustrates the calculation of stroke length.

The crank pin fastened to the sliding block can be adjusted by a lever placed outside the column. Through the bevel gears placed at the centre of the bull gear, the radial slide lead screw can be rotated. This rotation of leadscrew changes the position of the sliding block to move towards or away from the bull gear centre. The stroke length of the ram is adjusted by placing the sliding block at a required position from the centre of the bull gear.

Note: The stroke length of the ram and its position should not be adjusted when the machine is in operation. The machine should be stopped before these adjustments are made.

3.8 Method of table movement

1. The table moves in a cross direction when the crossfeed screw is rotated.
2. A crank handle is provided to rotate the crossfeed screw manually.
3. When the crossfeed screw is rotated in clockwise direction, the table will move towards left.
4. When the elevating screw is rotated, the table slides up and down on the face of the column.
5. As the handles meant for crossfeed screw rotation and elevating screw rotation are placed side by side, it is not possible to operate both of them at the same time.
6. The work mounted on the table is provided with required feed only during the end of the return stroke.

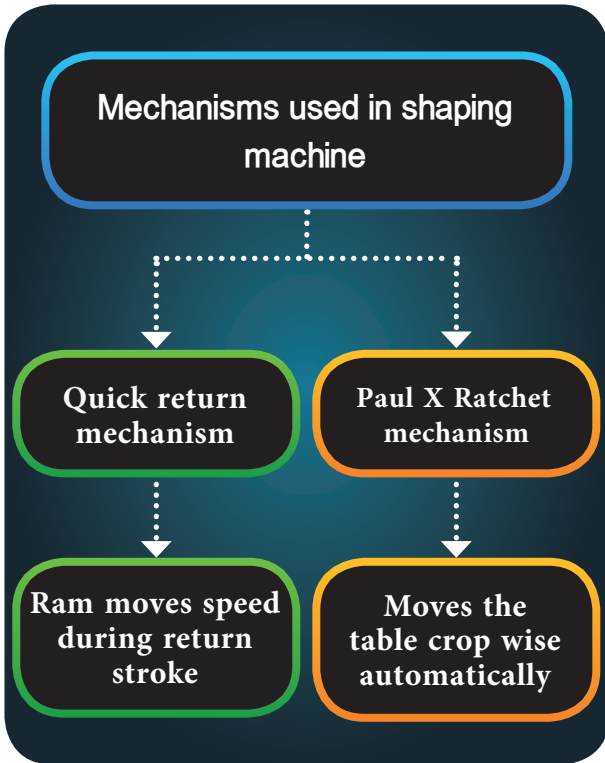

3.9 Pawl and Ratchet mechanism

The table of a shaping machine travels in a cross direction when the crossfeed screw is rotated. The cross feed screw is attached to the ratchet wheel. A spring 'pawl' is positioned to be placed between the teeth of the ratchet wheel. The pawl is housed within a frame known as rocker

arm. The bull gear placed inside the column of the shaping machine drives the gear B through the gear A.

There is a diametric slot provided on the face of the gear B. A crank pin is attached to a slider placed in the slot. The bottom of the rocker arm and crank pin are connected by a connecting rod. The rotation of the gear B makes the crank pin to rotate. This movement makes the rocker arm to rock about the centre of the ratchet wheel. The pawl makes the ratchet to rotate by a small amount in one direction only. As the cross feed screw is attached to the ratchet wheel, the rotation of the ratchet wheel will make the table to move in a cross direction.

If the direction of the table feed is to be reversed, the pawl is turned about 180° from its position. The ratchet wheel and the crossfeed screw will rotate in the opposite direction resulting in the table movement in the opposite direction.

Pawl & Ratchet mechanism is shown in Figure

When power feed is not necessary for the table, the pawl is disengaged from the ratchet wheel.

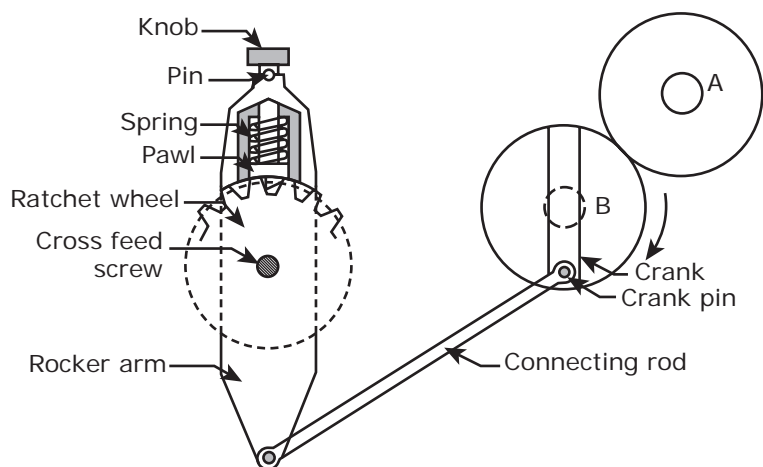

Pawl and Ratchet Mechanism

3.10 Swivel toolhead

The toolhead of a shaper holds the cutting tool rigidly. It is fitted on the face of the ram. The vertical slide of the toolhead can be moved vertically or at a particular angle to provide vertical and angular feed movement to the tool. It allows the tool to have an automatic relief during the return stroke of the ram.

The toolhead has a swivel base attached to the circular seat on the ram. The swivel base has angular graduations marked on it. As the vertical slide is mounted on the swivel base of the toolhead, it may be set and moved at any desired angle to machine angular surfaces like 'V' grooves and dove tail grooves.

The downfeed screw handle is rotated to move the vertical slide up and down. A graduated dial is placed on the top of down feed screw to control the amount of depth of cut or feed accurately.

Apron consisting of clapper box, clapper block and tool post is clamped on the vertical slide by a screw. By releasing the clamping screw, the apron can be swiveled either towards left or

towards right with respect to the vertical slide. The clapper box has two vertical walls within which the clapper block is housed. It is connected to the clapper box with the help of a hinge pin. This arrangement provides relief to the tool while machining vertical or angular surfaces. The tool post is mounted upon the clapper block. The tool post is provided with a slot to accommodate the tool and a screw to hold the tool rigidly on the tool post.

The clapper block fits securely inside the clapper box to provide a rigid tool support during forward stroke. On the return stroke, a slight frictional drag of the tool on the work lifts the block out of the clapper box and prevents the tool cutting edge from dragging on the work surface. Fig. illustrates the swivel toolhead of a shaper.

3.11 Work Holding Devices

Workpieces can be held and supported on the shaper table directly or by having some special devices. Depending on the size and shape of the work, it may be

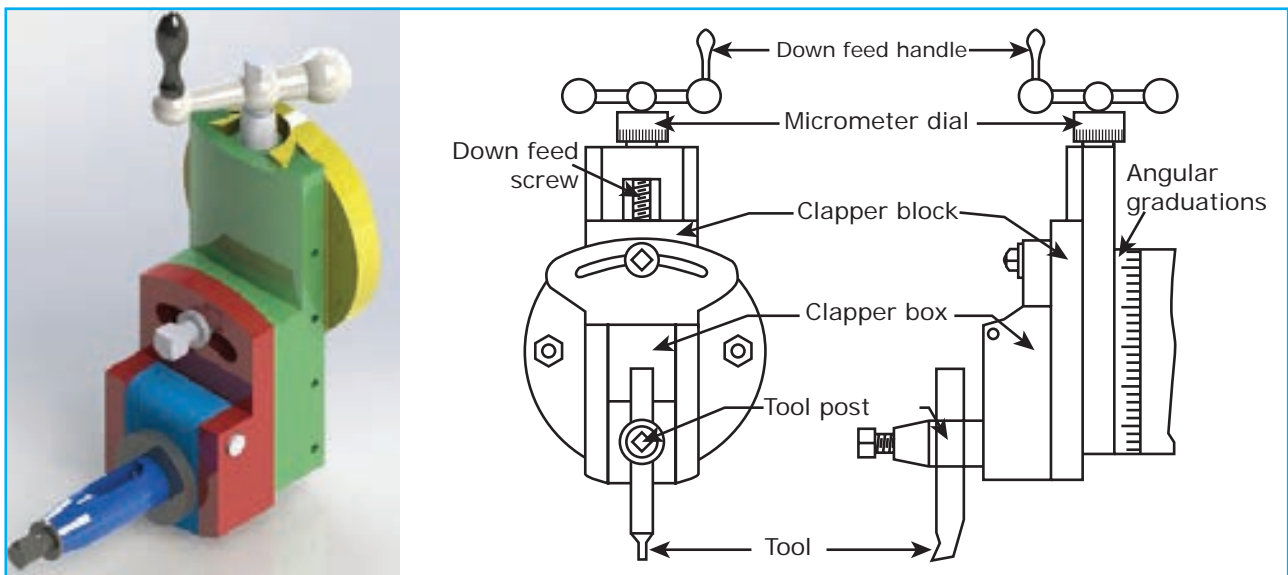

Swivel Tool Head

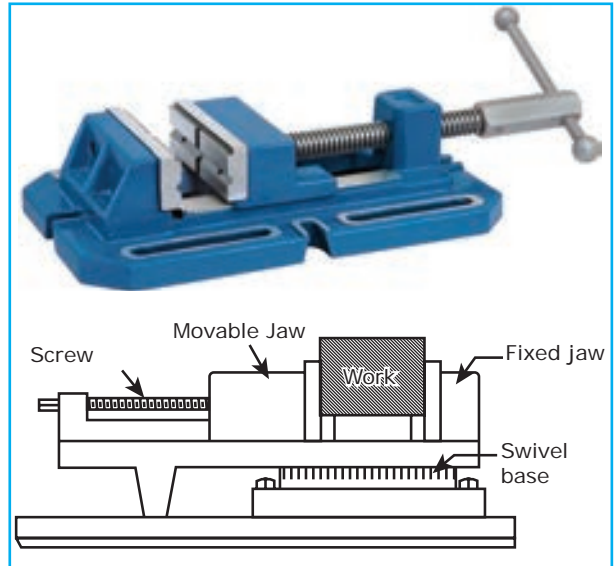
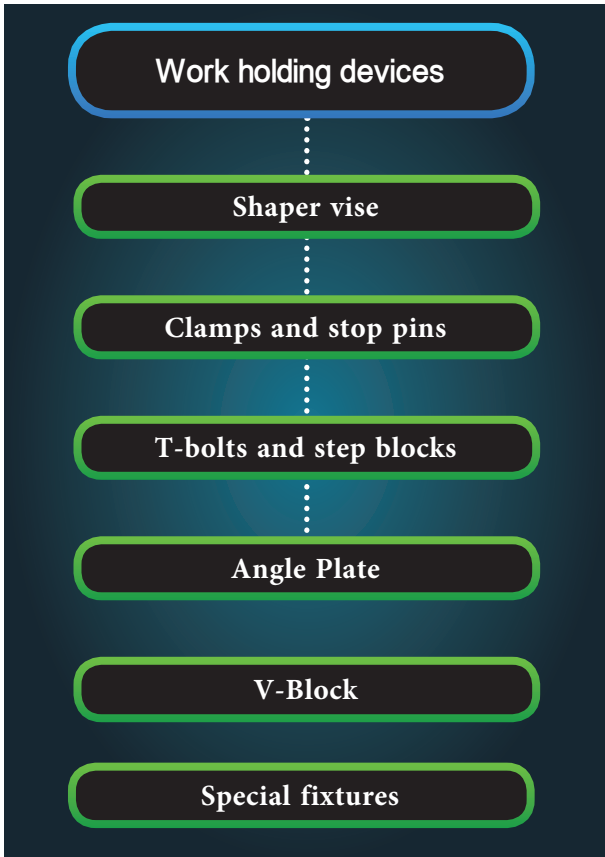

Vise

strip at one end and by a stop pin at the other side. The screw is tightened to secure the work properly on the machine table. The use of stop pin is shown in Figure.

supported on the table by any one of the following methods.

1. Shaper vise
2. Clamps and stop pins
3. T-bolts and step blocks
4. Angle Plate
5. V-Block
6. Special fixtures

Vise

Vise is the most common and simple work holding device used in a shaper. Different types of vises are used in a shaping machine according to the need and they are: 1. Plain Vise, 2. Swivel Vise, 3. Universal Vise

Clamps and stop pins

T-bolts are fitted into the T-slots of the table. The work is placed on the table. The work is supported by a rectangular

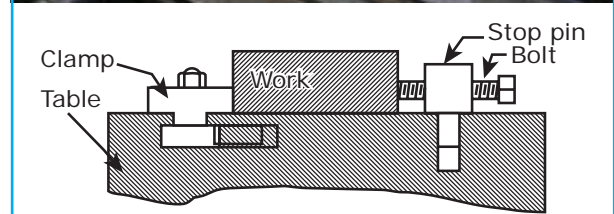

Clamp and Stop pin

T-bolts and step blocks

The step blocks are used in combination with T-bolts and clamps to hold the work directly on the machine table. The t-bolts are fitted in the T-slots of the machine table. One side of the clamp holds the work and the other side

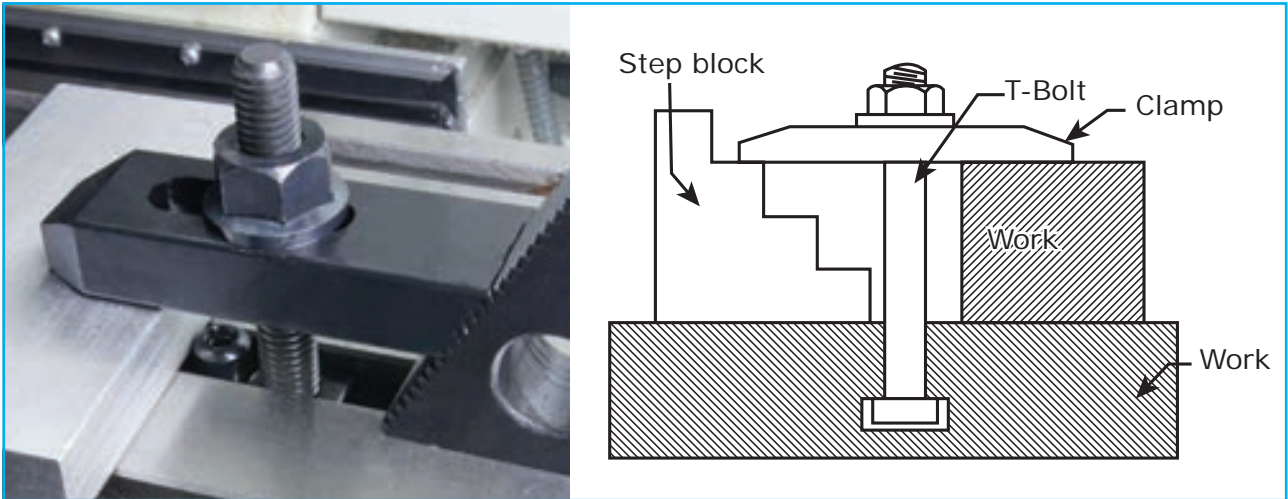

T-bolt and clamp

rests on a step of the step block. The different steps of the block are useful in leveling the clamp when holding works of different heights. A nut on the top of the clamp holds the work rigidly. 'T' bolt, clamp & step block.

Angle Plate

Angle plate resembles the English alphabet 'L'. It is accurately machined to have two sides at right angles. Slots are provided on both sides. One of the sides is bolted to the machine table and the workpiece are held on the other side. The use of an angle plate is shown in Figure.

V-block

V-block is a metal block having a 'v' shaped groove on it. It is used for holding cylindrical workpieces. Operations like keyway cutting, slot cutting and machining flat surfaces can be performed on the cylindrical workpieces held on a 'v' block. The use of a 'V' block is illustrated in Figure.

Special fixtures

When internal keyways are to be machined on the holes, the work is held with a special fixture. The fixture has a V-block attached to it and the cylindrical work is mounted on it.

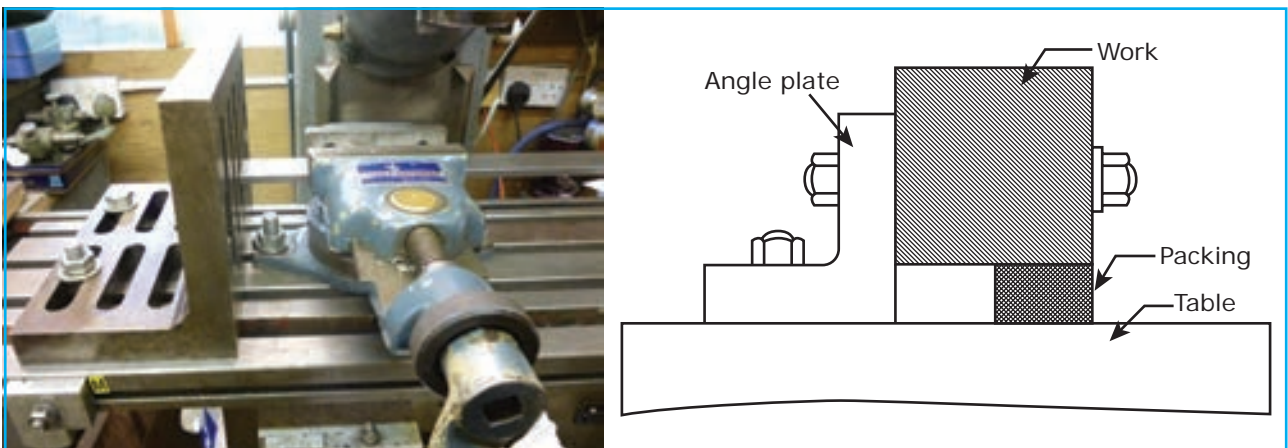

Angle Plate

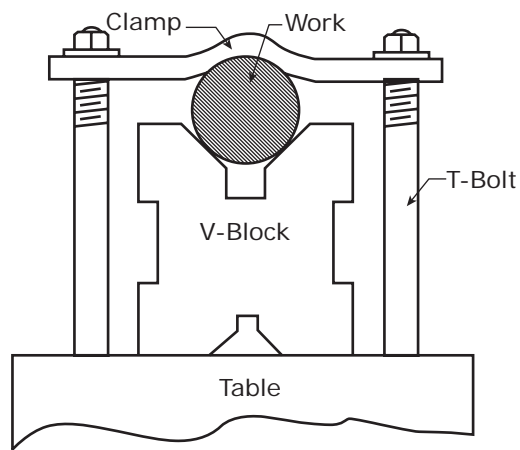

V - Block

3.12 Types of shaper tools

The material of the cutting tool used in a shaping machine should have more hardness and temper when compared to the material of the workpiece. So, the shaper tools are made of the following materials.

1. High Carbon Steel
2. High Speed Steel
3. Carbide tipped tool
4. Stellite tool

Types of shaper tools

According to the type of operation, various tools are used in a shaper. They are

Right hand (R.H) tool

- This is a tool used for machining by moving the job from right to the left.

Left hand (L.H) tool

- This is a tool used for machining by moving the job from left to right.

Roughing tool

- When it is required to remove a good amount of material from the workpiece,

roughing tools are used. The cutting edge will be very thick, sharp and strong to withstand the cutting pressure and to dissipate the heat generated at the cutting point. The surface obtained will be very rough.

Finishing tool

After the rough machining is performed, the finishing tool is used to obtain a very high quality of surface finish. The cutting edge will be either flat or slightly convex. Different types of shaper tools are shown in Figure.

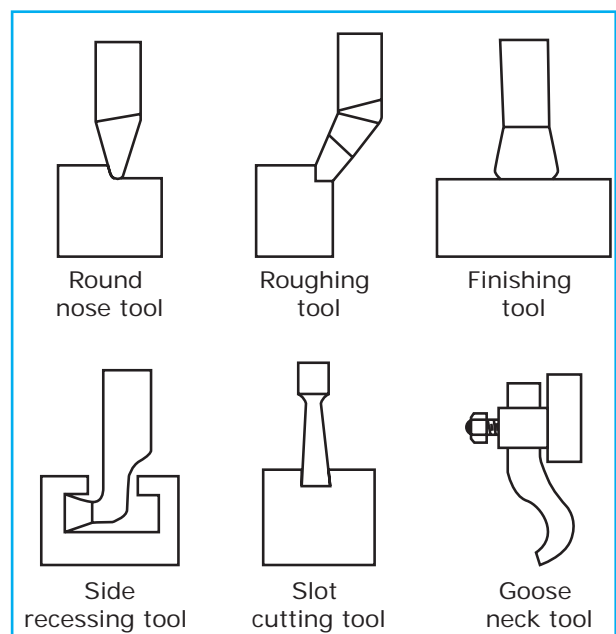

Types of shaper tools

Goose neck tool

This is a special type of tool used for finish machining. Very good surface finish will be obtained. The cutting edge of goose neck tool has a springy action. The tip of the cutting edge lies in the same line with the rear side of the shank.

Slot cutting tool

Wide rectangular or square grooves are known as slots. Rough machining of the slot is carried out using round nose tool. After that, a slot cutting tool is used for finish machining work.

T-slot cutting tool

The central rectangular (or square) slot is first machined using rough machining tool and then by using parting tool (or slot cutting tool). After that, a T-slot cutting tool is used to machine underneath the rectangular groove.

Form tool

Form tools are made to suit some specific requirements for machining V shaped grooves or similar special shaped grooves in concave or convex form.

3.13 Setting of shaper table, vise and toolhead

The machining accuracy will not be perfect if the machine table and toolhead are not set properly. When the sides are perpendicular, it is referred as squareness. Parallelism means the two sides are absolutely parallel to each other. Alignment is an arrangement in which the relative positions of the table, the jaws of the vise, the toolhead and the ram are perfect. The above setting of the table,

work and the tool are done with the help of test bars and feeler gauges.

3.14 Types of shaping operations

Different types of operations are performed in a shaper machine. They are broadly classified as

1. Regular operations
2. Special operations

General operations

Machining horizontal surfaces

A shaper is mostly used to machine a flat, true surface on a workpiece. Horizontal surfaces are machined by moving the work mounted on the machine table at a cross direction with respect to the ram movement. The clapper box can be set vertical or slightly inclined towards the uncut surface. This arrangement enables the tool to lift automatically during the return stroke. The tool will not drag on the machined surface.

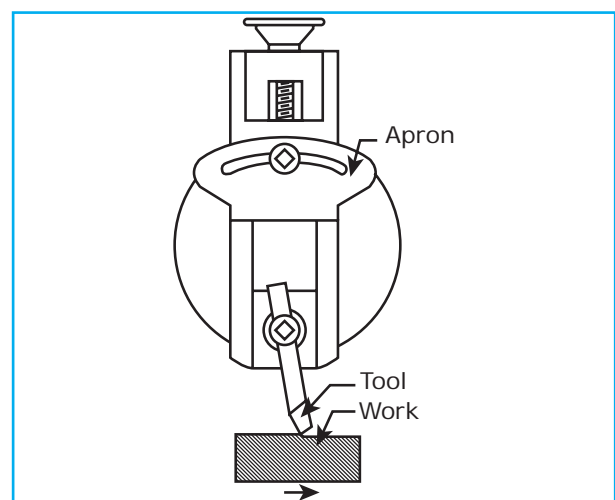

Machining Horizontal Surfaces

Machining vertical surfaces

A vertical cut is made while machining the end of a workpiece, squaring up a block or machining a shoulder.

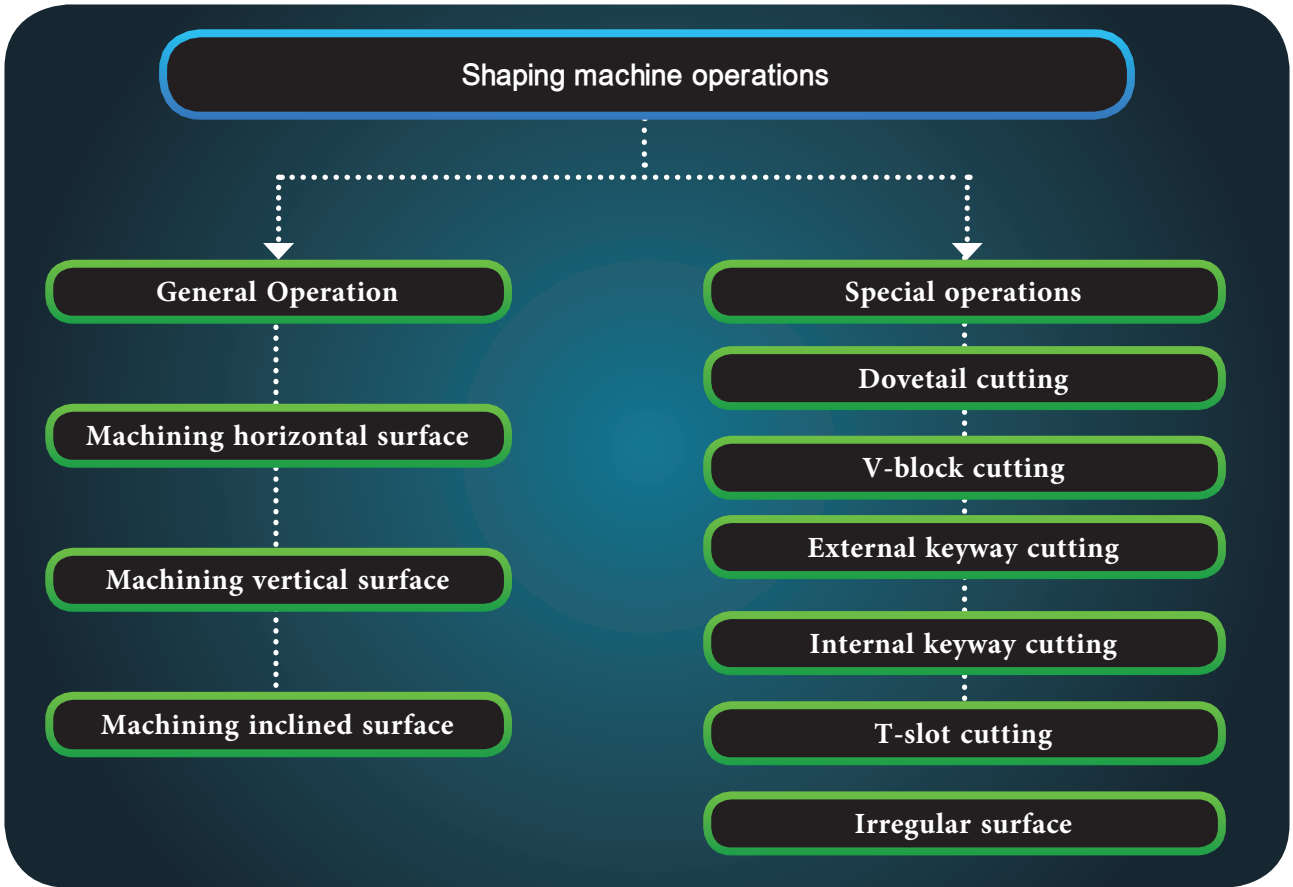

The feed is given to the tool by rotating the downfeed screw of the vertical slide. The table is not moved vertically for this purpose. The apron is swiveled away from the vertical surface being machined as shown in the diagram.

Machining Inclined surfaces

If the surface to be machined is neither horizontal nor perpendicular, the surface is called inclined surface. Machining ‘V’ grooves and dovetail grooves are some examples for angular machining.

Machining the inclined (angular) surfaces can be done in several ways.

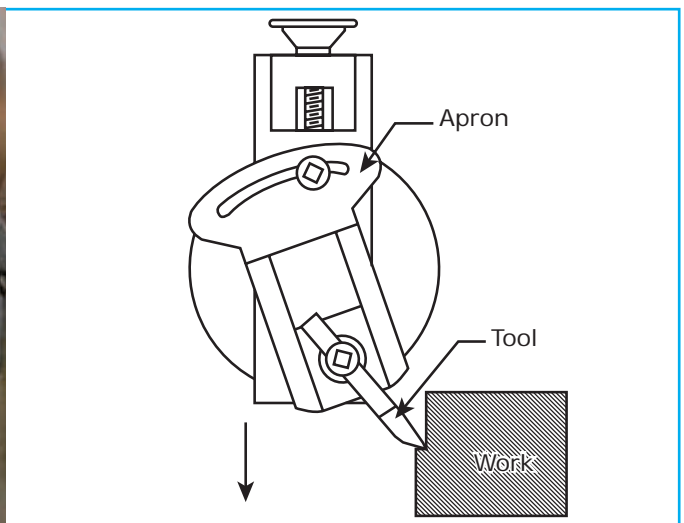
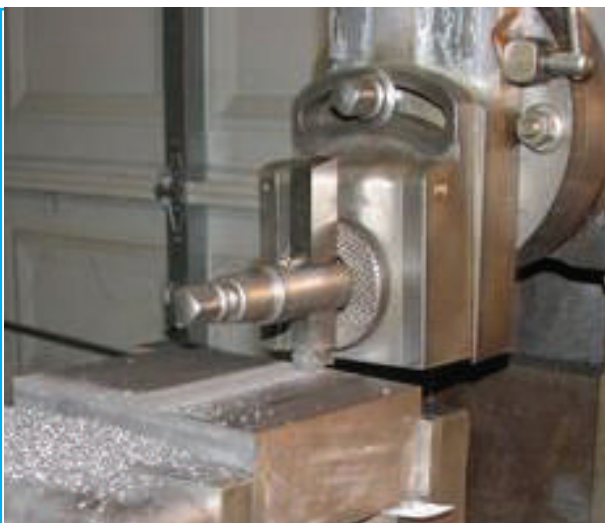

Machining vertical surfaces

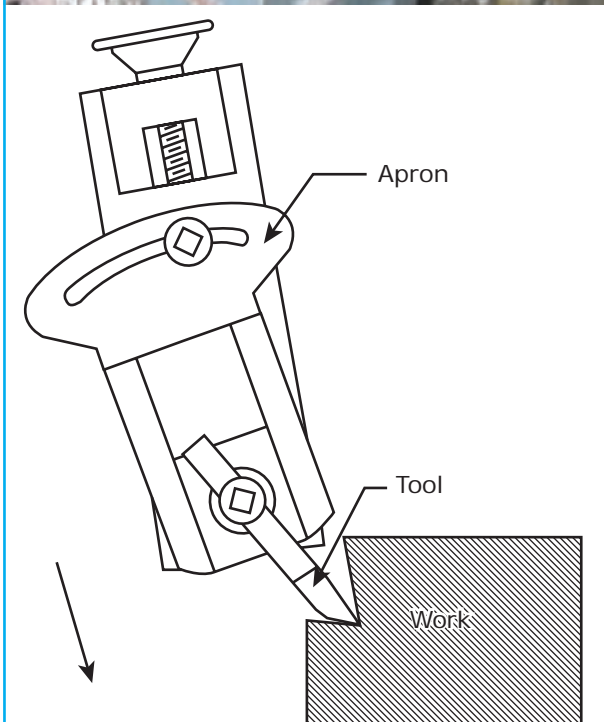

Machining Inclined surfaces

3.15 Special Machining Problem

Apart from machining horizontal, vertical and vertical flat surfaces, the shaping machine can do some special machining operations.

Machining dove tail groove

Dove tail joint is machined on two separate pieces of work as male and

female elements. The required shape is marked on the face of the work and the unwanted metal is first removed by the round nose tool. A special form tool is used to finish the machining.

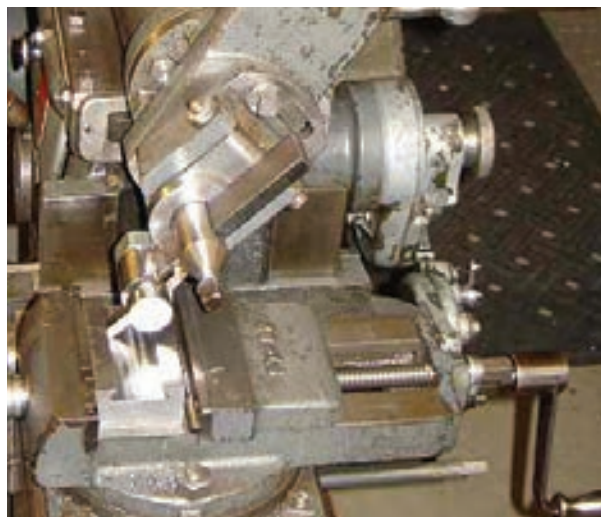

Machining Dove tail groove

Machining external keyways

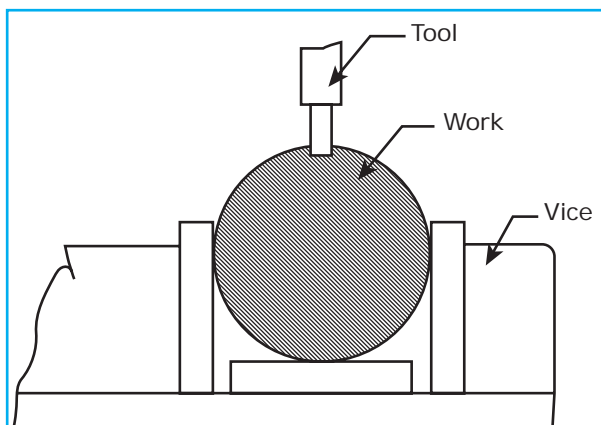

Machining External Keyways

Machining external keyways refers to the cutting of long slots along the length of cylindrical rods. Initially a round nose tool is used and then a square nose tool is used to finish the operation. A hole of depth equal to the depth of the keyway is made at the blind end to leave a clearance to the tool at the end of the stroke. When a keyway is cut at the middle of the shaft, holes are drilled at both ends of the keyway.

Machining internal keyways

Internal keyways are cut inside the holes of gears and pulleys. It is done by holding the tool on a special tool holder called 'snout bar'. The snout bar is directly fitted on the clapper block.

Illustrate machining a external keyway and a internal keyway respectively.

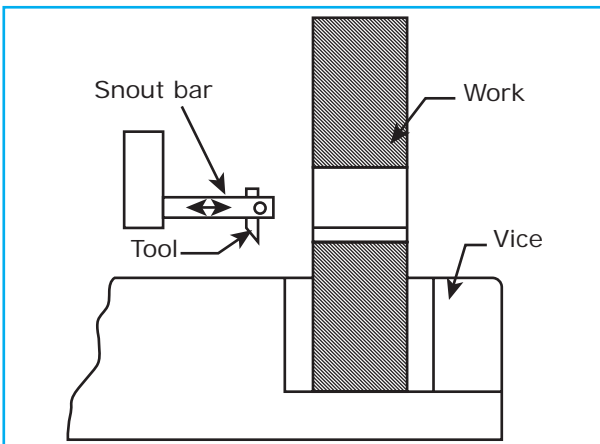

Machining internal keyways

T-slot machining

The shape of the T-slot is marked on the face of the work. A parting off tool is fitted on the toolpost and a rectangular slot is machined at the middle for the required depth. The broad base of the 'T' slot is machined by a T-slot cutting tool. Figure illustrates machining a 'T' slot.

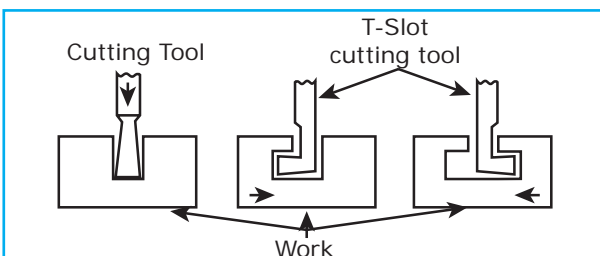

'T' slot cutting

Machining a rack gear

Rack gear cutting is a process of cutting teeth elements at linear pitch on a flat piece of work. Firstly, the groove is machined with a square nose parting tool.

Then, the groove is further machined with a form tool confirming the shape of the teeth.

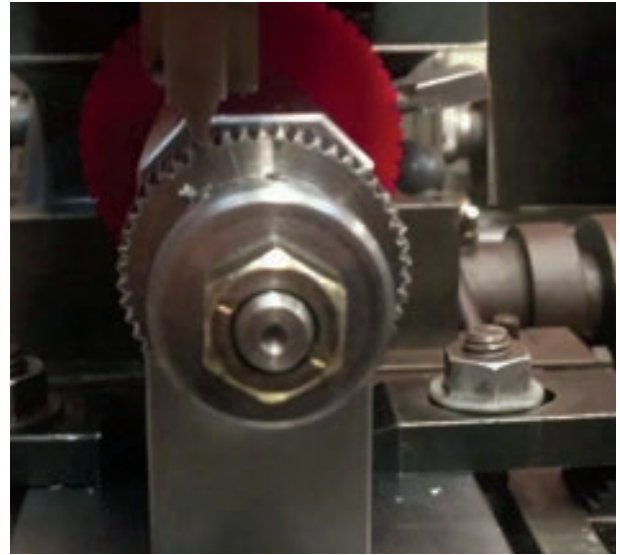

Machining Rackgear

3.16 Cutting speed, depth of cut and Feed

Cutting speed

The distance an object travels in a particular period of time is known as speed. In a shaper, the cutting speed is the speed at which the metal is removed by the cutting tool in a period of one minute. In a shaper, the cutting speed is considered only during the forward cutting stroke. This is expressed in metre per minute.

The cutting speed differs to suit different machining conditions like work material, the finish required, and the type of the tool and the rigidity of the machine.

Depth of cut

Depth of cut is the thickness of metal that is removed during machining. It is the perpendicular distance measured between the machined surface and the uncut surface of the workpiece. It is expressed in mm or in inches.

Feed

Feed is the relative movement of the work or tool in a direction perpendicular to the axis of reciprocation of the ram per double stroke. It is expressed in mm per stroke.

3.17 Coolant

Due to the friction between the tool and the work surface during machining, heat is generated. The tool loses its cutting capacity and the machined surface is hardened. Coolant is used on the surfaces to avoid damage to the cutting edge of the tool as well as to the machined surface.

Soluble oil is mixed with water to be used as a suitable coolant. One part of the oil is mixed with fifteen parts of water to be used as coolant. Usage of water as coolant may result in rust formation on the metal parts. Lubricants cannot be used as coolants.

3.18 Safety precautions

The following safety precautions should be observed while working on a shaping machine.

Safety precautions regarding operators

1. No alteration or adjustment should be done on the machine parts while the machine is functioning.
2. Clamps holding the work should not be adjusted while the machine is in operation.
3. The machine is to be stopped before cleaning the metal chips.
4. The sharp edges of the work should be handled with care.
5. The measuring of the work should be done only after the machine is switched off.
6. The operator should not seek the assistance of others for starting and stopping the machine.
7. Machining of precision parts and internal surfaces of the workpiece are to be carried out with great care and attention.
8. The operator should stay away from direction of the ram movement.

Safety hints regarding the shaping machine

1. The workpiece is to be positioned in such a way that ram will not hit the workpiece while performing the forward stroke.
2. Stroke length of the ram and the position of stroke are to be set correctly before performing the operation.
3. Proper holding of the work should be ensured. Work holding devices like clamps and vise jaws should not come in the way of the reciprocating tool.
4. We have to ensure that the tool or the tool post or the ram will not hit the job or the job holding clamps or the vise jaws.
5. The machine should be stopped before making any adjustment to the stroke length, position of stroke, apron and tool position.

ACTIVITIES

1. Visiting the nearby workshop or polytechnic or engineering college for knowing what type of operations done in shaping machine.
2. To make different models shapes of cubic square, cubic rectangle and prism by using wood (or) thermocol sheet.

QUESTIONS



Part I.

Choose the correct option 1 Mark

1. The shaping machine was designed by
 - a. Henry Maudslay
 - b. Eli Whitney
 - c. Michael Faraday
 - d. James Nasmith
2. The operation mainly done on a shaping machine is
 - a. Turning
 - b. Drilling
 - c. Machining a flat surface
 - d. Thread cutting
3. The mechanism used to move the shaper table automatically is
 - a. Back gear mechanism
 - b. Crank & slotted link mechanism
 - c. Tumbler gear mechanism
 - d. Pawl & Ratchet mechanism
4. The part involved in reciprocation by quick return is
 - a. Table
 - b. Ram
 - c. Column
 - d. Crossrail
5. The ratio of forward stroke time to return stroke time is
 - a. 3:2
 - b. 5:3
 - c. 1:3
 - d. 1:2
6. The part used to lift the tool while the ram moves the returning stroke
 - a. Tool-head
 - b. Work-table
 - c. Clapper-block
 - d. Cross-slide

Part II.

Answer the following questions in one or two sentences 3 Marks

7. Define “Shaping”.
8. List any four parts of shaper.
9. What is the use of crank & slotted link mechanism?
10. Define “cutting speed” of shaping machine.
11. Define “feed” of a shaping machine.
12. Mention the “depth of cut” of shaping machine.
13. What is the use of a clapper box?
14. What is the use of swivel tool head of a shaping machine?

Part III.

Answer the following questions in about a page

5 Marks

15. List out the types of shaping machines.
16. Write short notes on
 - a. changing the stroke length of the ram
 - b. Position of the ram

Part IV.

Answer the following Questions in detail.

10 Marks

17. Draw a neat diagram of a shaping machine and explain its important parts.
18. Explain the crank & slotted link mechanism of quick return of the ram with a diagram.
19. Explain the ratchet & pawl mechanism with a diagram.
20. Explain any four work holding devices used in a shaping machine with diagrams.
21. Explain any four operations performed in a shaping machine with diagrams.

Grinding Machine



Learning Objectives

- Students to understand the various types of grinding machines, different types of operation performed in it, Natural and Artificial abrasives and its type, manufacturing of grinding wheel and mounting of grinding wheel, dressing truing and super finishing process.



Puran thooimai neeraan amaiyum aganthooimai
Vaaimaiyaar kaana padum. –Kural 298

Outward purity the water will bestow, inward purity from truth alone will flow (or) purity of body is produced by water and purity of mind by truthfulness.

CONTENTS

- | | |
|------------------------------------|---|
| 4.1 Introduction | 4.10 Abrasive |
| 4.2 Types of grinding machine | 4.11 Grinding wheel specification |
| 4.3 Non precision grinding machine | 4.12 Mounting grinding wheel |
| 4.4 Precision grinding machine | 4.13 Glazing, loading and chattering |
| 4.5 Size of grinding machine | 4.14 Balancing of grinding wheel |
| 4.6 Centreless grinding | 4.15 Cutting speed, Feed and Depth of cut |
| 4.7 Grinding operations | 4.16 Precision operations |
| 4.8 Wet and Dry grinding | 4.17 Safety precautions |
| 4.9 Grinding wheel | |



Grinding machine

Ambrose Webster was an American scientist; citizen of Massachusetts invented the small grinding machine in 1860.

Grinding wheel

The scientist named Suyin Palson was invented grinding wheel with mixture of emery powder, clay and water in 1873.

4.1 Introduction

Grinding is a metal cutting operation where metal is cut by a rotating abrasive wheel. This machine on which grinding the operation is performed is called a grinding machine.

Grinding is done to obtain very high dimensional accuracy and good surface finish on the work place. The accuracy of grinding process is 0.000025 mm. The amount of material removed from this process is very less.

4.2 Types of grinding machines

According to the accuracy of the work to be done on a grinding machine, they are classified as

1. Rough grinding machines or Non-Precision grinding machines
2. Precision grinding machines



4.3 Non-Precision grinding machine

The non-precision grinding machines are used to remove unwanted projections from casting and welding, when the surface finish is not important. The main types of non-precision grinders are

1. Hand grinding machine
2. Bench grinding machine
3. Floor stand grinding machine
4. Flexible shaft grinding machine
5. Swing frame grinding machine
6. Abrasive belt grinding machine

Hand grinding machine



It is a small grinder which can be carried from one place to another place easily. A small grinding wheel is mounted at the end of motor shaft. The motor is connected by along wire to the main switch box. It is used for grinding large forgings, casting, welded joints and sheet metal work etc.

Bench grinding machine

This grinder is mounted on a bench. Two grinding wheels are connected to both ends of the motor shaft. The wheels are covered by guards. Work rest is provided for supporting the work piece while grinding.



Bench grinding machine

4.4 Precision Grinding Machine

Precision grinders are used for finishing parts to a very accurate dimension. The main types of precision grinders are

1. Cylindrical grinding machines
2. Internal grinding machines
3. Surface grinding machines
4. Tool and cutter grinding machines
5. Special grinding machines

Cylindrical grinding machine

The workpiece is held between two centres and used to grind external surfaces like cylinders, taper cylinders and cylindrical faces is called cylindrical grinding machine. There are two types of cylindrical grinding machines, they are

1. External cylindrical grinding machine
2. Internal cylindrical grinding machine

External cylindrical machine

In a cylindrical work piece to grind external surface like cylindrical and taper cylinders is called external cylindrical grinding machine.

Base

The base is made of cast iron and rest on the floor. It supports all other parts of the grinder. The top of the base is accurately

machined and provides guideways for the table to slide on. The base houses the table driving mechanism.

Tables

The tables are mounted on top of the base. There are two tables namely upper table and lower table. The lower table slides on the guideways on the bed. Table can be moved by hand or power.

Upper table is mounted on the lower table. Upper table can be swiveled upto $\pm 10^\circ$ and clamped in position. Adjustable trip dogs are clamped in longitudinal slots at the side of the lower bed. These trip dogs actuate the table reversing lever, to control table movement.

Head stocks

The head stock is situated at the leftside of the upper table. It supports the workpiece by means of a centre and drives it by means of a dog. It may hold and drive the workpiece in a chuck. It houses the mechanism meant for driving the work. The head stock of a universal grinding machine can be swiveled to any required angle.

Tailstock

The tailstock is situated at the rightside of the table. It can be adjusted and clamped in various positions to accommodate different lengths of workpieces.

Wheel head

The wheel head is placed over the bed at its backside. The wheel head may be moved at right angles to the table guideways. It is operated by hand or by power to feed the wheel to work. The wheel head carries a grinding wheel.

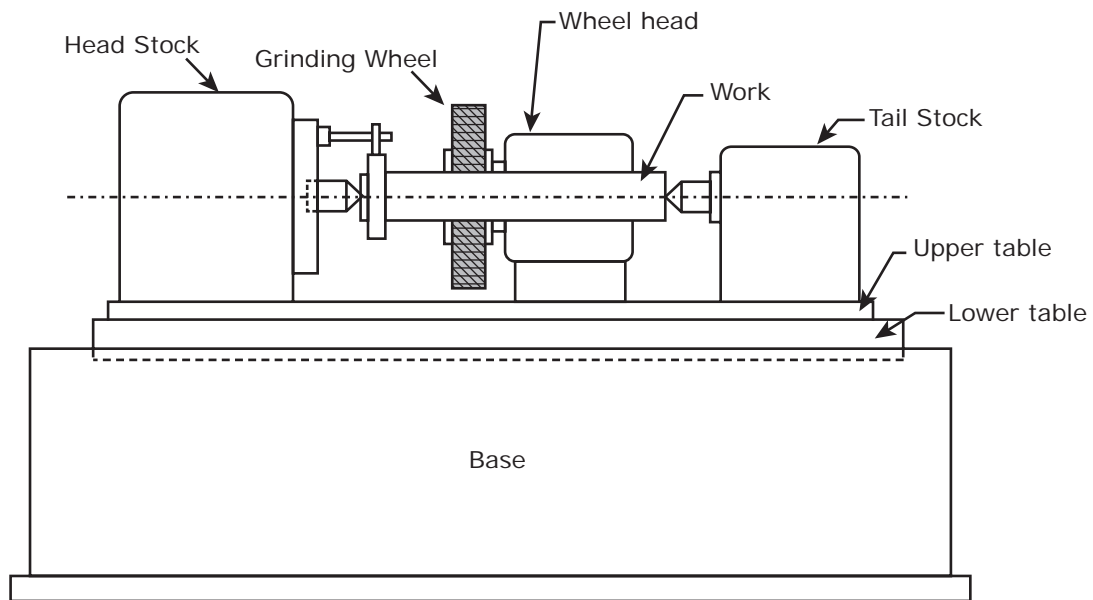
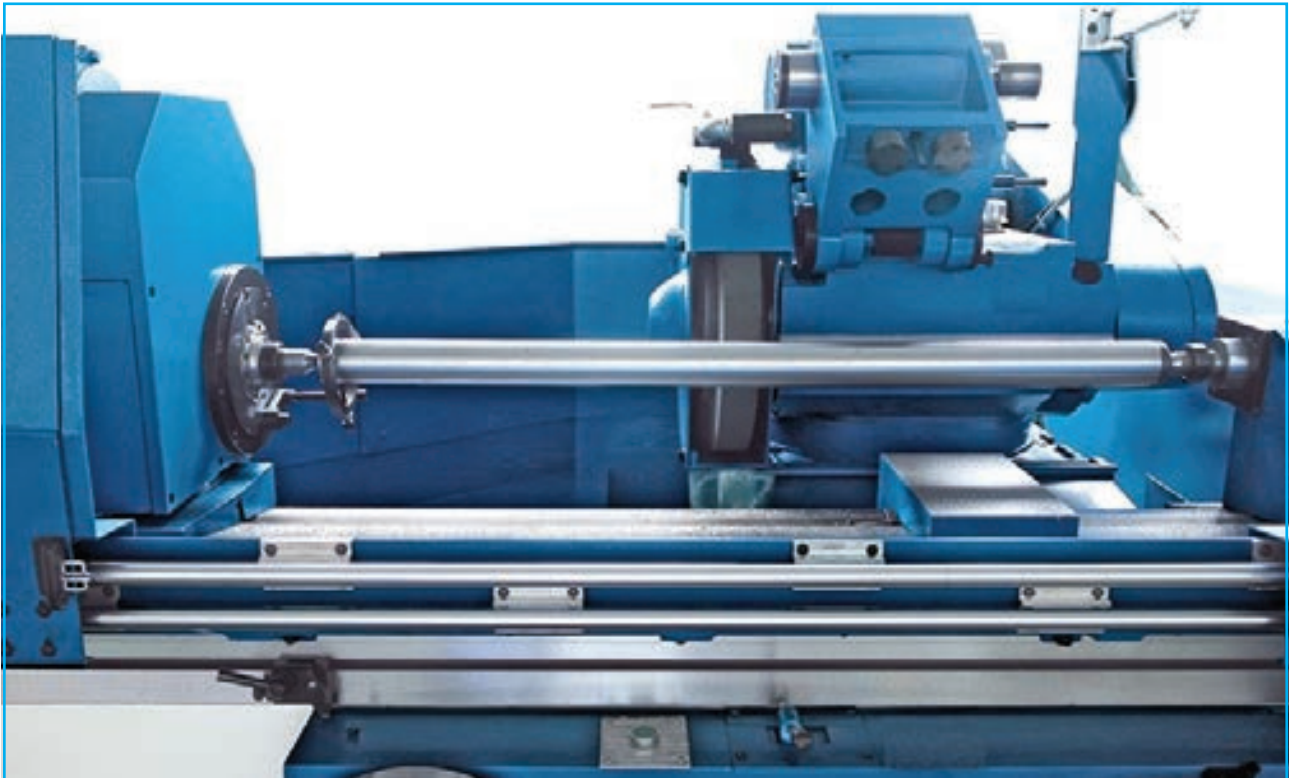

Cylindrical grinding machines

Separated motor is used for driving the grinding wheel. The grinding wheel rotates at about 1500 to 2000 r.p.m.

Internal cylindrical grinding machine

Internal grinders are used to grinding internal surfaces of straight and tapered holes.

Surface grinding machine

Surface grinding machines are employed to finish plain or flat surfaces horizontally or at any angle. There are four different types of surface grinders. They are

1. Horizontal spindle and reciprocating table type.
2. Horizontal spindle and rotary table type.

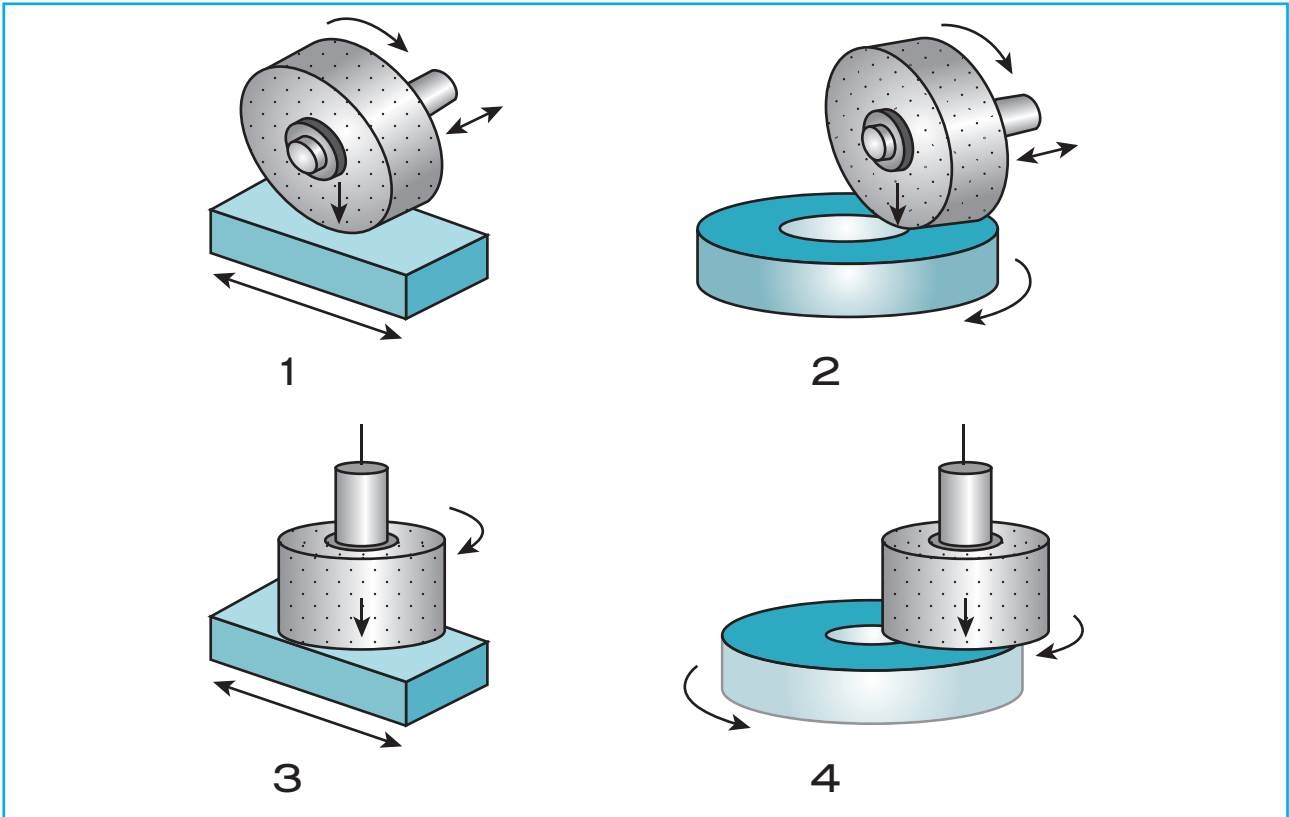

Surface Grinding Machine

3. Vertical spindle and reciprocating table type.
4. Vertical spindle and rotary table type.

Horizontal spindle surface grinding machine

The majority of surface grinders are of horizontal spindle type. In the horizontal type of the machine, grinding is performed by the abrasives on the periphery of the wheel. Though the area of contact between the wheel and the work is small, the speed is uniform over the grinding surface and the surface finish is good.

The grinding wheel is mounted on a horizontal spindle and the table is reciprocated to perform grinding operation.

Base

The base is made of cast iron. It is a box like casting which houses all the table drive mechanisms. The column is mounted at the back of the base which has guideways for the vertical adjustment of the wheel head.

Saddle

Saddle is mounted on the guideways provided on the top of the base. It can be moved at cross towards or away from the column.

Table

The table is fitted to the carefully machined guideways of the saddle. It reciprocates along the guideways to provide the longitudinal feed. The table is provided with 'T' slots for clamping

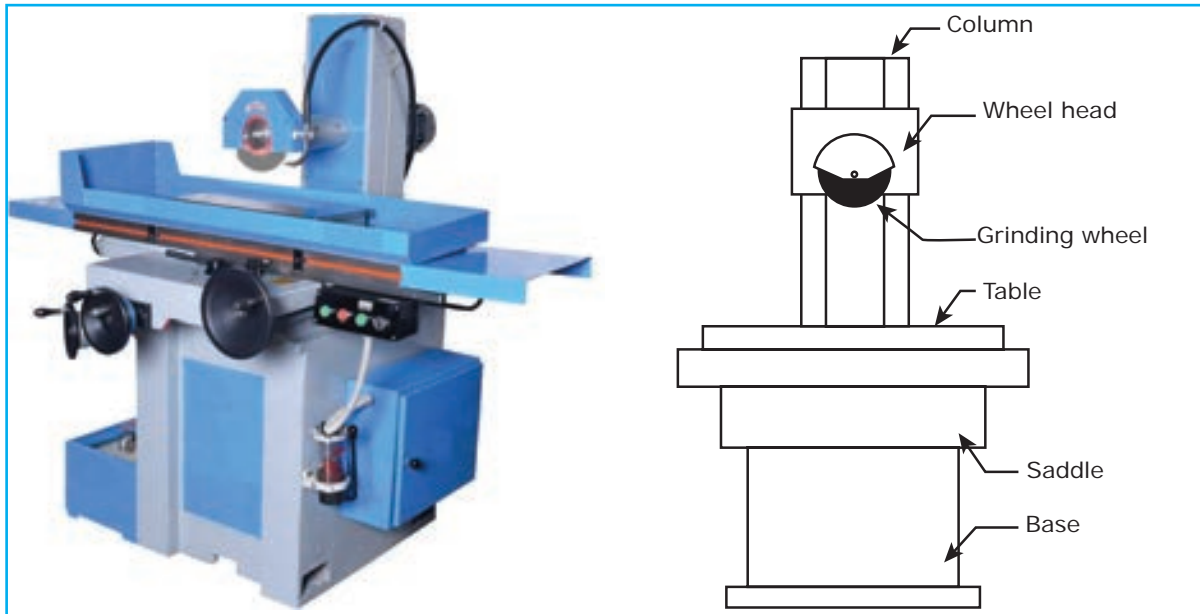

Horizontal Spindle Surface Grinding Machine

workpiece directly on the table or for clamping fixtures or magnetic chuck.

Wheel head

An electric motor is fitted on the wheel head to drive the grinding wheel. The wheel head is mounted on the guideways of the column, which is secured to the base. It can be raised or lowered with the grinding wheel to accommodate workpieces of different heights and to set the wheel for depth of cut.

Vertical spindle surface grinding machine

The face or sides of the wheel are used for grinding to the vertical type surface grinders. The area of contact is large and stock can be removed quickly. But a criss-cross patterns of grinding scratches are left on the work surface. Considering the quality of surface finish obtained, the horizontal spindle type machines are widely used.

The grinding wheel is mounted on the vertical spindle of the machine. The

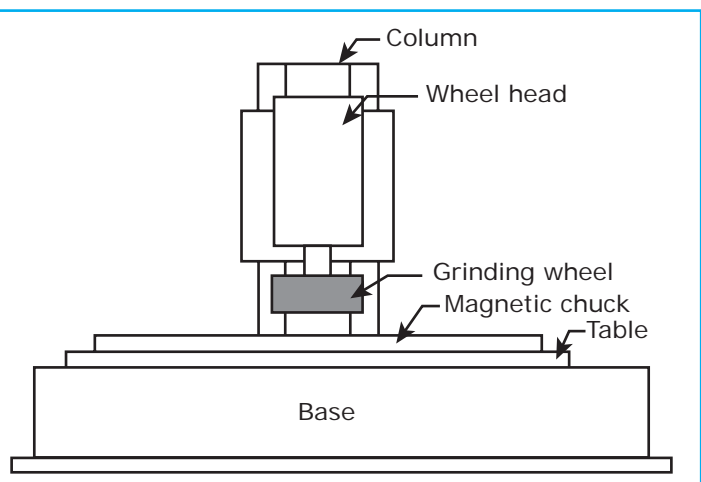

Vertical spindle surface grinding machine

work is held on the table and grinding is done.

The base of the machine is a box like casting. The base is very similar to the one of the horizontal spindle grinding machine. It houses all the table drive mechanism.

The table is mounted on the base on top of the work table a magnetic chuck is mounted. A grinding wheel is mounted on the wheel head which slides vertically on the column. The table is made to reciprocate or rotate to bring the work surface below the grinding wheel to perform grinding.

Tool and cutter grinding machine

Tool and cutter grinders are used mainly to sharpen the cutting edges of various tools and cutters. They can also do light surface. Cylindrical and internal grinding to finish jigs, fixtures, dies and gauges.

Base

The base of the machine gives rigidity and stability to the machine. It is bolted rigidly to the floor. It supports all the

other parts of the machine. The base is a box type and houses all the mechanisms for the saddle movements.

Saddle

The saddle is mounted directly on the top of the base and slides over it. The column supporting the wheel head is mounted on the saddle. It can be moved up or down and swiveled to each side.

Table

The table rests and moves on a top base, which is mounted over the saddle. The table has two layers. The work table is mounted on the sub-table which has 'T' slots for mounting the work and attachments used on the machine. The work table can be swiveled while grinding tapers.

Wheel head

The wheel head is mounted on a column on the back of the machine. It can be swiveled and positioned in the base for different set-up. A straight wheel and a cup wheel are mounted on either sides of the wheel head.

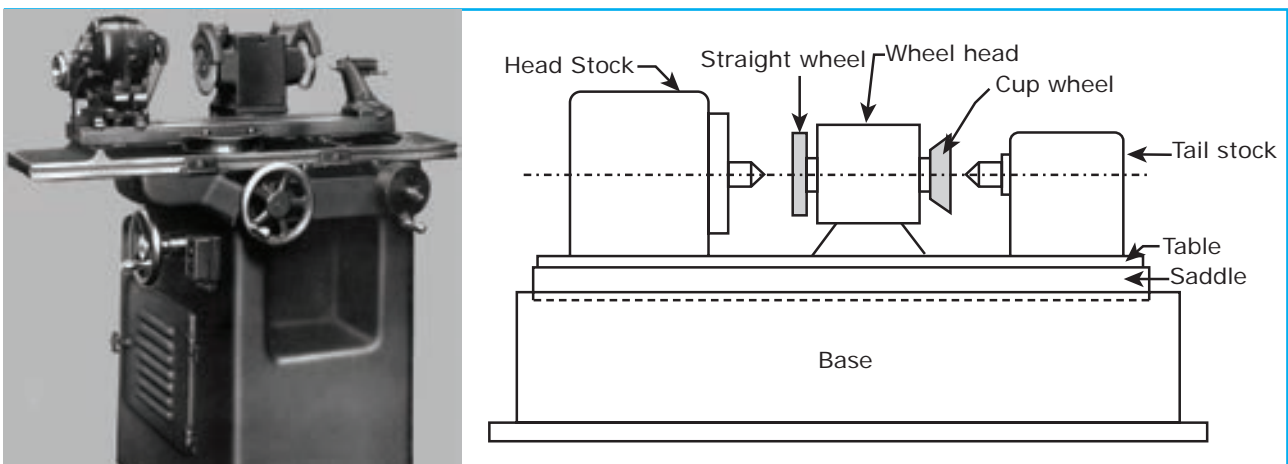

Tool and cutter grinding machine

4.5 Size of grinding machine

The size of a grinding machine is specified according to the size of the largest work piece that can be mounted on the machine.

Cylindrical grinding machine, is specified by the diameter and length of the largest workpiece that can be held.

Internal cylindrical grinding machine is specified by the maximum diameter of the workpiece that can be held in the chuck and maximum stroke length of the wheel.

Surface grinding machine, is specified by the table area and the maximum height of the grinding wheel from the table surface.

Rotary table or chuck type grinding machine is specified by the maximum diameter of the table or chuck. Tool and cutter grinder is specified by the maximum size of tool and cutters that can be sharpened and dressed.

4.6 Centreless grinding

Centreless grinding is a method of grinding external, cylindrical, tapered and formed surfaces on workpieces, the workpiece is not held between the centres

or in chucks. It is placed in a floating condition between two grinding wheels. There are two types of centreless grinding and they are

1. External centreless grinding
2. Internal centreless grinding

External centreless grinding

Two wheels – a grinding and regulating wheel are used in external centreless grinding. Both wheels are rotated in the same direction. The work is placed upon the work rest and rotated between the wheels. The axial movement of the work pass through grinding wheel is obtained by tilting the regulating wheel at a slight angle from horizontal. An angular adjustment of 0 to 10 degrees provided in the machine for this purpose.

Internal centreless grinding

The principles of external centreless grinding are applied to internal centreless grinding also. Grinding is done on the inner surface of the holes. In internal centreless grinding, the work is supported by three rolls – a regulating roll, a supporting roll and a pressure roll. The grinding wheel contacts the inside surface of the workpiece directly opposite the regulating roll. The distance between

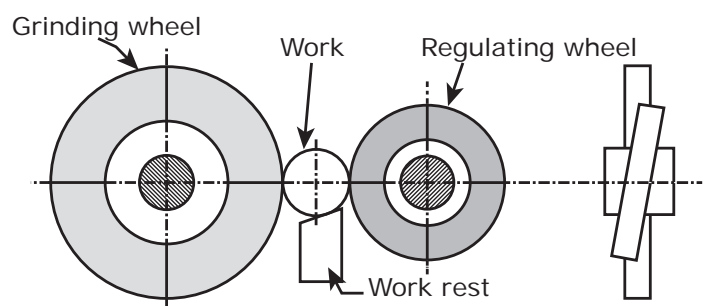

External centreless Grinding

the contours of these two wheels is the wall thickness of the work.

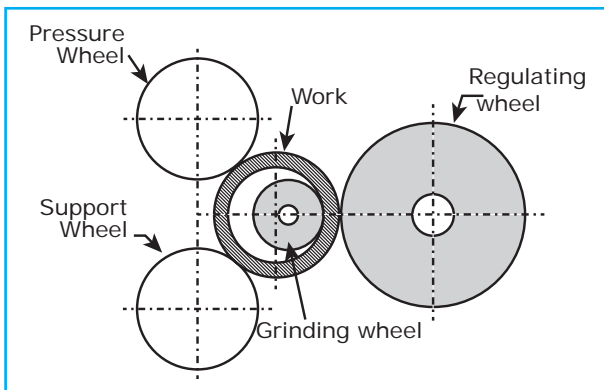

Internal Centreless Grinding

Advantage of centreless grinding

1. The workpiece is supported throughout the entire length, grinding is done very accurately.
2. Small, fragile or slender workpieces can be grind easily.
3. Work holding devices such as chucks, dogs, centres, mandrels are not required.
4. The process is continuous, it is best adapted for mass production.
5. The size of the work can easily be controlled.
6. Less skilled worker is sufficient.

Disadvantages of centreless grinding

1. In hollow work, there is no certainty that the outer diameter will be concentric with the inside diameter.
2. Works having multiple diameters are not handled easily.

4.7 Grinding operations

Grinding is metal cutting operations of removing excess material from metal parts by means of a rotating hard abrasive

wheel that act as a tool. The following operations are generally performed in a grinding machine.

1. Cylindrical grinding
2. Taper grinding
3. Gear grinding
4. Thread grinding

Cylindrical grinding

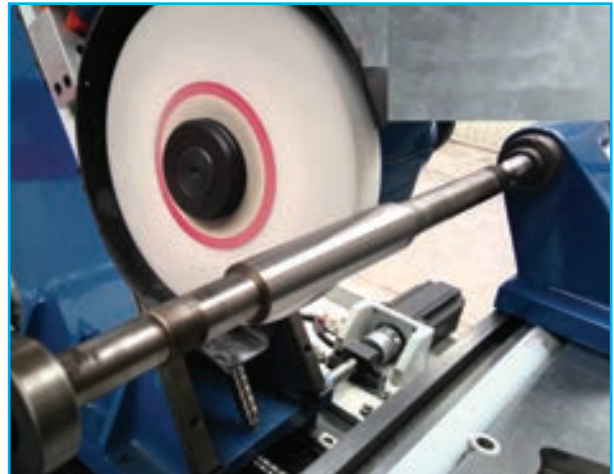

Cylindrical grinding is a metal cutting operation, where metal is cut by a rotating abrasive wheel in a cylindrical grinding is performed by mounting and rotating the work between two centres in a cylindrical grinding machine. The work is fed longitudinally against the rotating grinding wheel to perform grinding. The upper table of the grinding machine is set at 0° during the operation.

Taper Grinding

Taper grinding on long work pieces can be done by swiveling the upper table at required angle. If the work piece is short, the wheel hand may be swiveled by the taper angle. Another method of grinding external taper is to true the face of the grinding wheel by a diamond tool dresser to the required angle. In this case, the wheel head and the table are not swiveled.

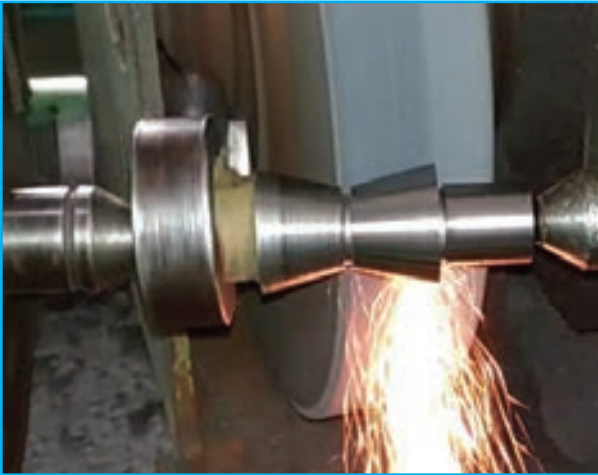

Form Grinding

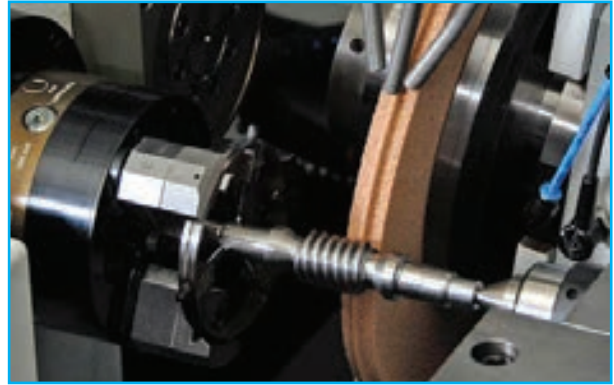

Thread grinding

Gear grinding

The teeth of gears are ground accurately on gear grinding machines for their shape. Gear grinding is done by the generating process or by using a form grinding wheel.

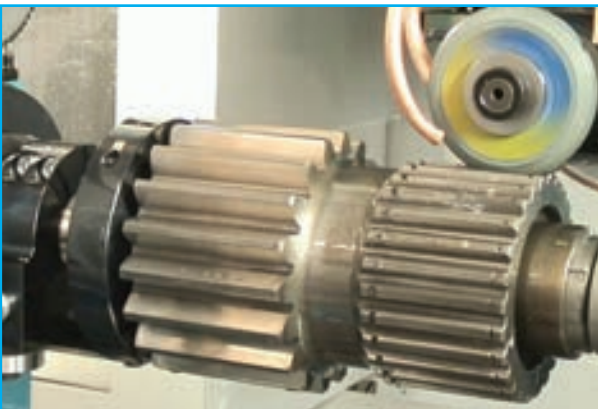

The generating process makes use of two saucer shaped grinding wheels. These wheels are used to grind two faces of successive teeth.

The forming process makes use of formed wheels to grind a tooth at a time. This is a very precise method of performing gear grinding.

Thread grinding

Thread grinding machines are used to grind threads accurately. The grinding wheel itself is shaped to the thread profile. These formed grinding wheels have one or multi threads on them.

4.8 Wet and dry grinding

The method of spreading a good quantity of coolant over the work surface and wheel faces during grinding is known as 'wet grinding'. Soda water is used as a coolant. The process of grinding generates high amount of heat normally about 2000°C. Various properties of the work material In order to reduce the heat generated during grinding, coolant is used. Wet grinding promotes long wheel life and better look of the ground surface. Coolant is pumped from the tank through pipelines.

Dry grinding is the method of doing grinding operation without applying coolant. Dry grinding produces undesirable effects on work surface. It leads to burring and discoloration of work surfaces. The cutting edges of the grinding wheel lose their cutting capacity. So, dry grinding should better be avoided.

4.9 Grinding wheel

A grinding wheel is a multi-tooth cutter made up thousands of hard particle known as abrasives having sharp edges. The abrasive grains are with a suitable bond, which act as a matrix to manufacture grinding wheels.

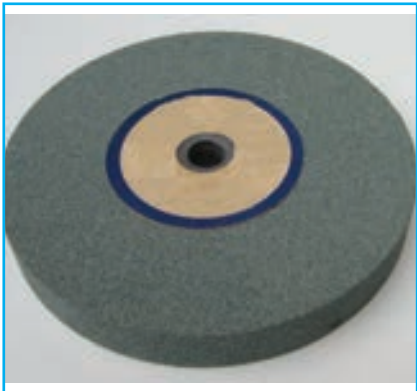

Solid grinding wheels



Segmented grinding wheels



Mounted grinding wheels

According to construction, grinding wheels are classified as follows.

1. Solid grinding wheels
2. Segmented grinding wheels
3. Mounted grinding wheels

4.10 Abrasive

Abrasives are used for grinding and polishing operations. It should be pure and have uniform physical properties of hardness, toughness and resistance to fracture. They are two types of abrasives

1. Natural abrasives
2. Artificial abrasives

Natural Abrasives

The natural abrasives are obtained from the Earth's crust. They include sand stone, emery, corundum and diamond.

Sandstone is used as abrasive to grind softer materials only. Emery is a natural aluminium oxide. It contains aluminium oxide, iron oxide and other impurities. Corundum is also a natural aluminium oxide. Emery and corundum have a greater hardness and better abrasive action than sandstone.

Diamond is the hardest natural abrasive. It is used in making grinding wheels to grain cemented carbide tools.

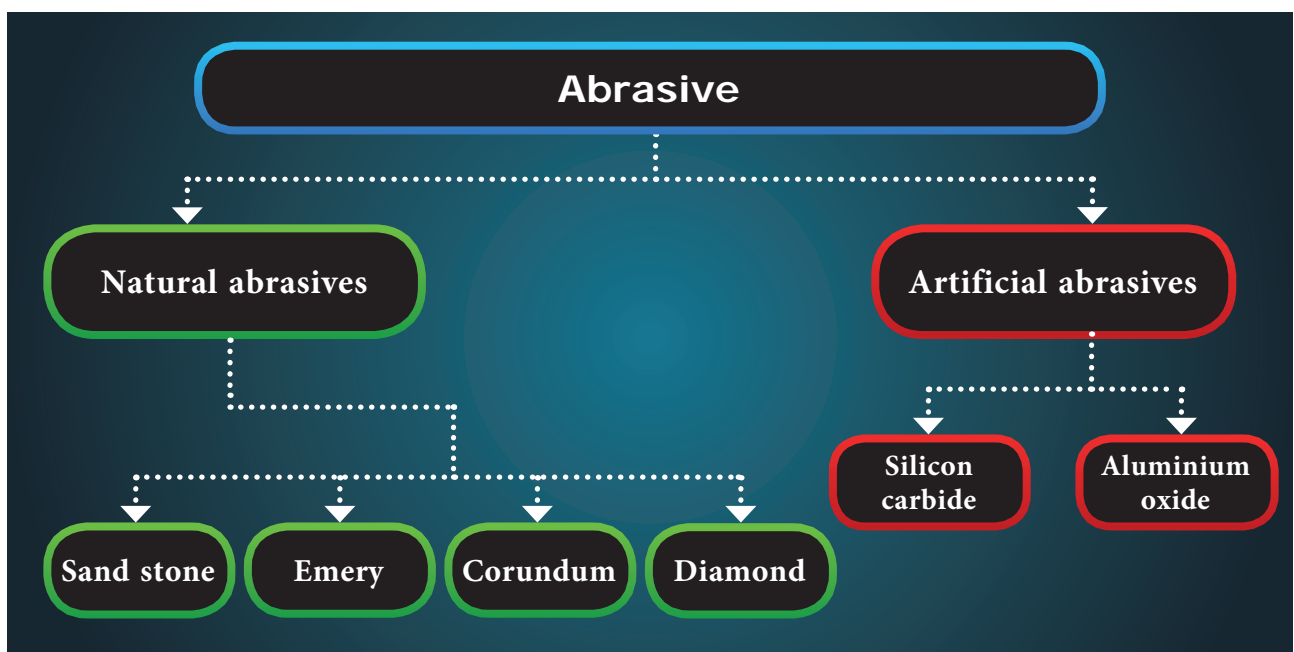

Artificial Abrasives

Artificial abrasives are classified as follows

1. Silicon carbide abrasives
2. Aluminium oxide abrasives.

Silicon carbide abrasives

Silicon carbide manufactured from 56% of silica, 34% of powdered coke, 2% of salt and 12% of saw dust in an electric furnace that is built of loose brick work. There are two types of silicon carbide abrasives green grit and black grit.

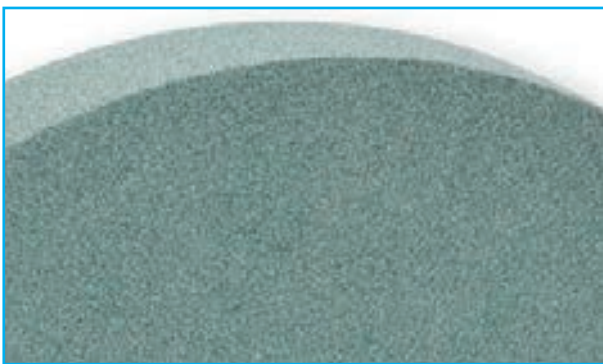

Silicon carbide

Silicon carbide is next to diamond in order of hardness, but it is not tough enough aluminium oxide. It is used for grinding materials of low tensile strength such as cemented carbides, ceramic materials, grey brass, bronze, copper, aluminium, vulcanized rubber etc. This is manufactured under trade names of carborundum. It is denoted by the letter 'S'.

Aluminum oxide

Aluminium oxide is manufactured by heating mineral bauxite, silica, iron oxide, titanium oxide etc mixed with ground coke and iron borings in an electric furnace.

Aluminum oxide is tough and not fractured, so it is better adopted to grinding materials of high tensile such as most steels, carbon steels, high speed

steels and tough bronzes. This is denoted by letter 'A'.

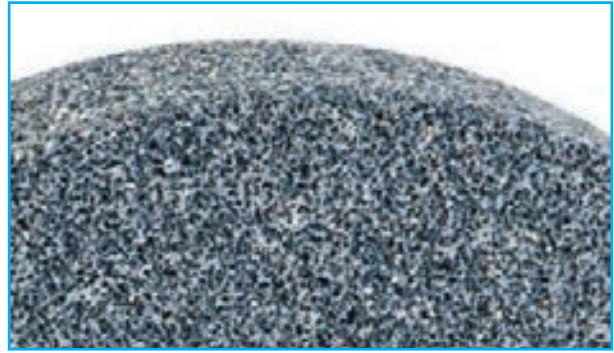

Aluminum oxide

Types of bond

A bond is an adhesive substance that is employed to hold abrasive grain together in the form of grinding wheels. There are several types of bonds. Different grinding wheels are manufactured by mixing hard abrasives with suitable bonds. The table containing the types of wheel manufactured using different types of bond and their symbols in given below.

Type of bond	Symbol	Grinding Wheel
Vitrified	V	Vitrified wheel
Silicate	S	Silicate wheel
Shellac	E	Elastic wheel
Resinoid	B	Resinoid wheel
Rubber	R	Vulcanized wheel
Oxychloride	O	Oxychloride wheel

Grit, Grade and structure

The grinding wheel is made of thousands of abrasives grains. The grain size or grit number indicated the size of the abrasive grains used in making a wheel or the size of the cutting teeth.

Grain size is denoted by a number indicating the number of meshes per

linear inch of the screen through which the grains pass when they are graded. There are four different groups of the grain size namely coarse, medium, fine and very fine. If the grit number is large, the size of the abrasive is fine and a small grit number indicates a large grain of abrasive.

Grain size	Grain numbers
Coarse	10 12 14 16 24
Medium	30 36 46 54
Fine	80 100 120 150
Very fine	220 240 280 320 500 600

Grade

The grade of grinding wheel refers to the hardness with which the wheel holds the abrasive grains in place. It does not refer to the hardness of the abrasive grains. The grade is indicated by a letter of the English alphabet. The term 'soft' or 'hard' refers to the resistance a bond offers to disruption of the abrasives. A wheel from which the abrasive grains can easily be dislodged is called soft whereas the one, which holds the grains more securely, is called hard. The grade of the bond can be classified in three categories.

Grade	Denoted English letters
Soft	A B C D E F G H
Medium	I J K L M N O P
Hard	Q R S T U V W X Y Z

Structure

The relative spacing occupied by the abrasives and the bond is referred to as structure. It is denoted by the number

and size of void spaces between grains. It may be 'dense' or 'open'. Open structured wheels are used to grinding soft and ductile materials. Dense wheels are useful in grinding brittle materials.

Structure	Identification number
Dense	1 2 3 4 5 6 7 8
Open	9 10 11 12 13 14 15 and above

4.11 Grinding wheel specification

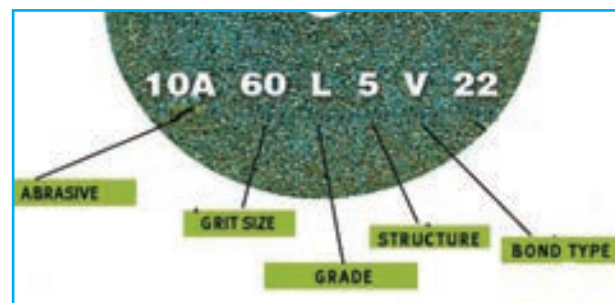

The Indian standard marking system of grinding wheels has been prepared with a view of establishing a uniform system of marking of grinding wheels to designate their various characteristics.

Prefix	Manufacturer's abrasive type symbol
First letter	Types of abrasive
First Number	Size of abrasive
Second letter	Grade of bond
Second number	Structure of the grinding wheel
Third letter	Types of bond

For specification of grinding wheel, outside diameter, width and centre hold diameter of the grinding wheel are also to be added. The meaning of the given marking on a grinding wheel

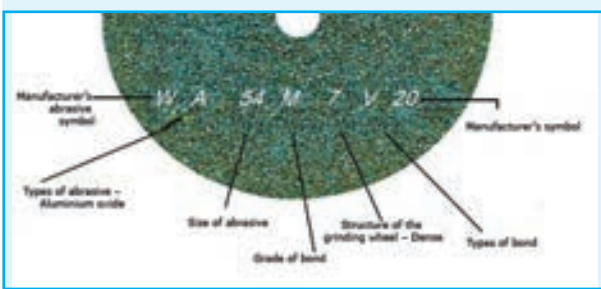

W A 54 M 7 V 20

- W – Manufacturer’s abrasive symbol
- A – Types of abrasive – Aluminium oxide
- 54 – Size of abrasive – Medium
- M – Grade of bond – Medium
- 7 – Structure of the grinding wheel – Dense
- V – Types of bond – Vitrified
- 20 – Manufacturer’s symbol



4.12 Mounting the grinding wheel

Great care must be taken in mounting the grinding wheels on the spindle the following points are important in connection with mounting of grinding wheel.



1. All wheels should be inspected before mounting to make sure that they have not damaged. The wheel is put on an arbor and is subjected to slight hammer blows. A clear, ringing, vibrating sound must be heard.
2. The grinding wheel should not be forced on the spindle and they should have an easy fit on the spindle.
3. The length of the lead bush should not be more than the width of the wheel face.

4. Flanges of equal diameter are fitted at both sides of the wheel. The flange diameter should be enough to hold the grinding wheel conveniently. At least the flange diameter must be equal to the half of the grinding wheel diameter.
5. The sides of the wheel and the flanges should be flat. Flanges contact the wheel only with the annular clamping area.
6. Washes of compressible materials such as cardboard, leather, rubber etc. Not over 1.5 mm thick should be fitted between the wheel and its flanges. The diameter of washers may be normally equal to the diameter of the flanges.

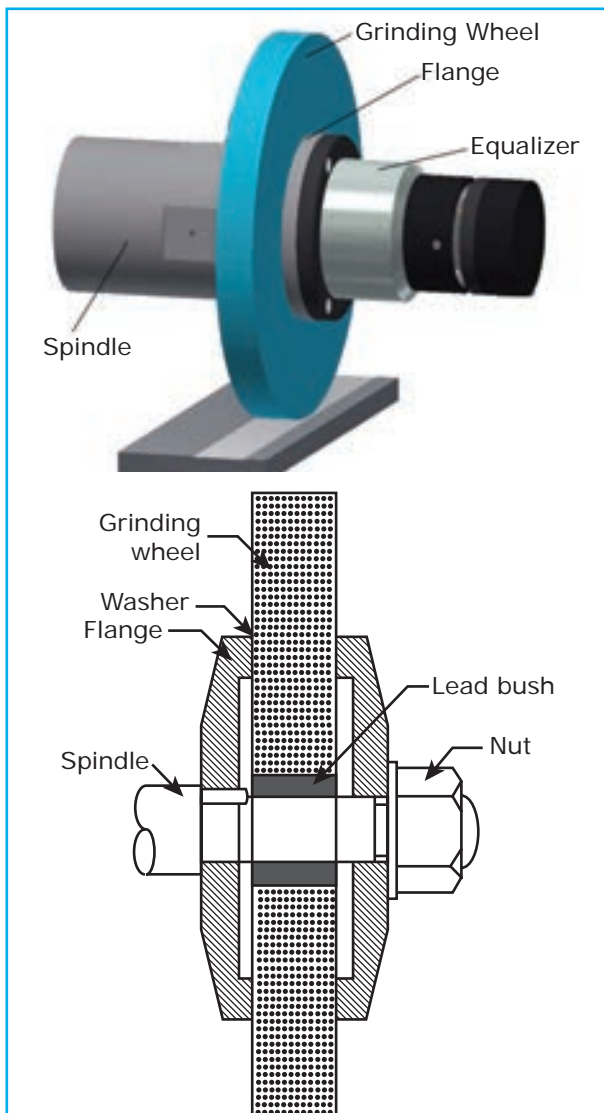

Method of Mounting Grinding Wheel

7. The inner flange should be keyed to the spindle, whereas the outer flange should have an easy sliding fit with the spindle.
8. The nut should be tightened to hold the wheel firmly.
9. Wheel guards should be fitted at required place before starting the grinding machine.
10. After mounting the grinding wheel, the wheel should be made to run idle for a period of about 10 to 15 minutes, grinding wheels must be dressed and trued before any work can be started.

4.13 Glazing, loading and chattering

Glazing

Glazing of the wheel is a condition in which the face cutting edge takes a glass like appearance. Glazing takes place if the wheel is rotated at very high speeds and is made with harder bonds. Rotating the wheel at lesser speeds and using soft bonds are the remedies. The glazed wheels are dressed to have fresh, sharp cutting edges.

Loading

The wheel is loaded in the particles of the metal being adhere to the wheel. The openings or pores of the wheel face are filled up with the metal. It is caused by grinding a softer material or by using a very hard bonded wheels and running it very slowly. It may also take place if very deep cuts are taken by not using the right type of coolant.

Chattering

Sometimes the way pattern of criss cross lines are visible on the ground surface. This condition is known as chattering. It takes place when the spindle bearings are not fitted correctly and because of the imbalance of the grinding wheel.

Dressing and truing of grinding wheel

If the grinding wheels are loaded or gone out of shape, they can be corrected by dressing or truing of the wheels.

Dressing

Dressing is the purpose of breaking away the glazed surface so that sharp particles

are again presented to the work. The common types of wheel dressers known as 'star'-dressers or diamond tool dressers are used for this purpose.

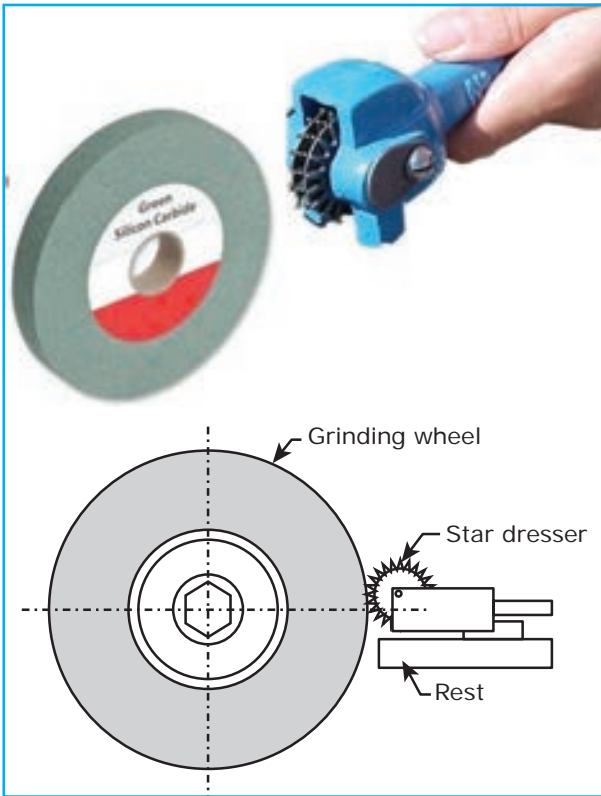

Dressing grinding wheel

Star dresser consists of a number of hardened steel wheels on its periphery. The dresser is held against the face of the revolving wheel and moved across the face to dress the wheel surface. This type of dresser is used particularly for coarse and rough grinding wheels.

For precision and high finish grinding, small industrial diamonds known as 'bort' are used. The diamonds are mounted in a holder. The diamond should be kept pointed down at an angle of 15° and good amount of coolant is applied while dressing very light cuts may be take with diamond tools.

Truing

The grinding wheel becomes worn from its original shape because of breaking

away of the abrasive and bond. Sometimes the shape of the wheel is required to be changed for form grinding. For these purpose the shape of the wheel is corrected by means of diamond tool dressers. This is known as truing of grinding wheels.

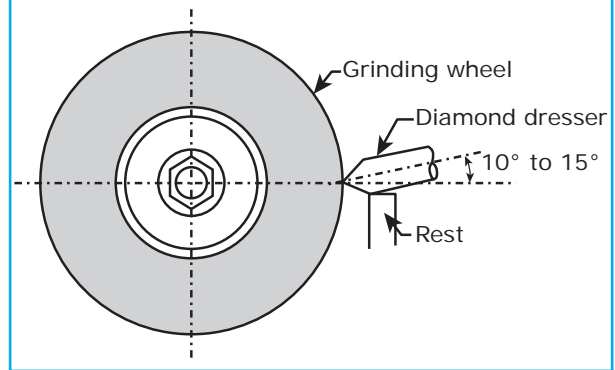

Truing

In first, the diamond dresser is mounted on a work rest upon the work table. Diamond tool dressers are set on the wheels at 15° and moved across with a feed rate must not exceeds 0.02 mm. A good amount of coolant is applied during truing of grinding wheels.

4.14 Balancing of grinding wheels

The weight and density of the grinding wheel should be evenly distributed throughout the body of the wheel is known as balancing. Otherwise the wheel will rotate without balance. Wheel balancing is to be made by dressing and



Wheel Balancing

truing of grinding wheels. The grinding wheels are balanced by mounting them on test mandrels.

The wheel along with the mandrel is rolled on knife edges to test the balance and corrected.

4.15 Cutting speed, Feed and depth of cut

Cutting speed

Cutting speed of a grinding process is the relative speed of the grinding wheel and the workpiece. It is expressed in metre/minute.

$$\text{Cutting speed (c.s)} = \pi DN / 1000 \text{ metre/ min}$$

$$\pi = 22/7 \text{ (or) } 3.14$$

D = The diameter of the grinding wheel in mm

N = The speed of the grinding wheel in RPM.

Feed in a grinding process is the longitudinal movement of the work mounted on the table per revolution of the grinding wheel. It is expressed in mm per revolution.

The longitudinal feed during rough grinding is approximately 0.6 to 0.9 of the width of the wheel and 0.4

to 0.6 of the width of the wheel during finish grinding.

Depth of cut

The thickness of the metal layer removed from the work in one pass of the wheel is known as depth of cut. It is expressed in mm. Depth of cut is kept ranging from 0.005 to 0.04 mm

4.16 Precision Operations

In a workshop, metal parts are manufactured by performing different operations in lathe, shaping machine, milling machine, drilling machine or grinding machine. In order to enhance the quality of surfaces of these parts, several surface finishing processes are performed on them. However, if a better finish is desired for looks, for accuracy, for wearing qualities or for any other reasons, one of the following processes is employed.

1. Lapping
2. Honing
3. Super finishing
4. Polishing
5. Buffing
6. Scraping
7. Electroplating

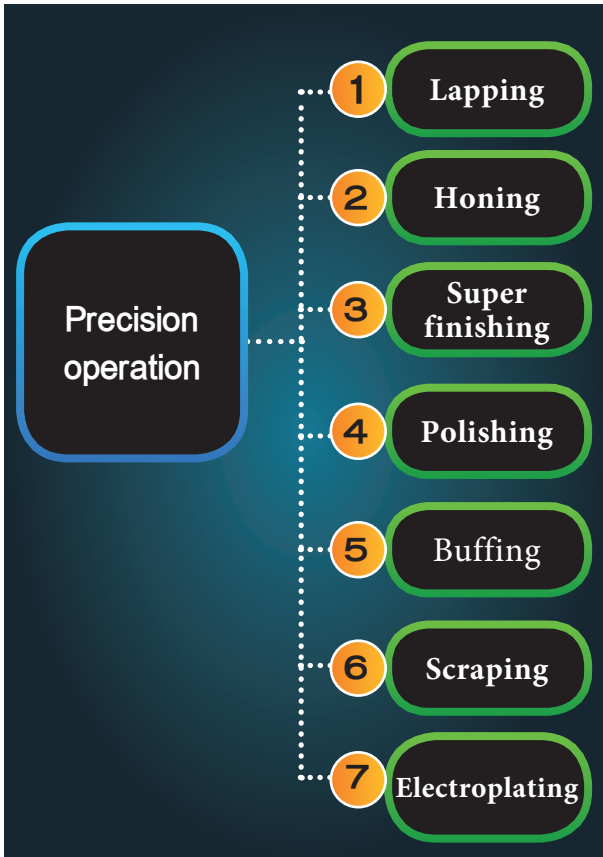

To perform lapping operations, lapping shoes and lapping mixture are needed. Laps may be made of almost any material soft enough to receive and retain the abrasive grains. They are made of cast iron, Brass, Copper lead or soft steel. It is made in different shapes. Lapping mixtures may be made abrasive power such as emery, corundum, iron oxide, chromium oxide mixed with oil or special pastes.

The face of the lap becomes charged with abrasive particles. Laps may be operated by hands or by machine. Cylindrical work may be lapped by rotating the work in a lathe and reciprocating the lap over the work. Flat surfaces may be lapped by holding the work against a rotating disc. Special lapping machines like vertical lapping machine, centreless lapping machine and abrasive belt lapping machines are also widely used.

Lapping

Lapping is the abrading process that is used to produce geometrically true surfaces correct minor surface imperfections, improve dimensional accuracy to provide a very close fit between two surface in contact. Very thin layers of metal (0.005 to 0.01 mm) are removed in lapping. Machining can be done to the accuracy of 0.1 micron.



Lapping

Honing

Honing is the abrading process done mostly for finishing round holed produced by drilling, reaming or boring by means of bonded abrasive stones called 'hones'. Honing is a machining process and it is used to remove metal upto 0.25 mm. The surface roughness value can be maintained between 0.025 and 0.4 microns. So honing is used to correct some out of roundness, tapers, tool marks and axial distortion.

Honing stones are used for performing honing tool head fitted with honing stones is fitted on spindle and rotates. The parts having holes to be honed are mounted on vises or suitable fixtures. The spindle is moved vertically to abrade the walls of the holes. A good quantity of coolant should be applied while honing.

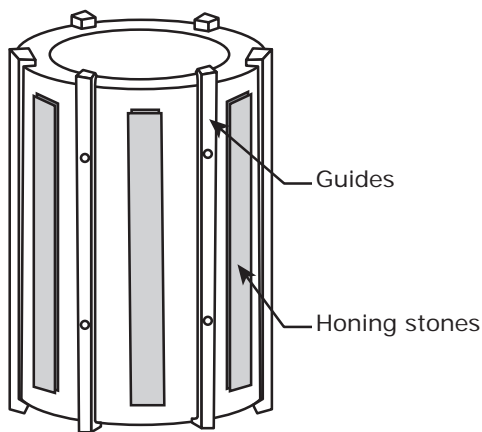

Honing

Honing can be done on materials like plastic, silver, brass, aluminium, cast iron, steel and cemented carbide. Journal bearings supporting the crank shafts and long holes found in the barrels of guns are generally honed. There are two types of honing machines namely vertical and horizontal.

Superfinishing

The process of superfinishing is an operation intended to produce an extremely high quality of surface finish. The surface roughness value can be maintained between 0.015 and 0.32 microns. A very thin layer of metal (0.005 mm to 0.002 mm) is removed by using very fine size of abrasives (size of 400 to

600) in super finishing. It can be done on both external and internal surfaces.

The grinding stones are made to reciprocate and the work piece is made to rotate or reciprocate. A fine surface is obtained by admitting coolant mixed with kerosene. Using some special machines, super finishing is performed on crank shaft, journal bearings and cam shafts.

Polishing

Polishing is a surface finishing operation performed by a polishing wheel for the purpose of removing metal to take out scratches tool marks and other defects from rough surfaces. Polishing is performed only to provide better looks. Polishing wheels are made of leather, paper, canvas, felt or wool. The abrasive grains are setup sometimes on the faces of the wheel and work is held against it and rotated to give the desired finish.



Polishing

Buffing

Buffing is used to give a much higher, reflective finish that cannot be obtained by polishing. Buffing wheels are made of felt pressed and glued layers of a variety of cloth. The abrasive may consist of iron oxide, chromium oxide, emery, etc. The abrasive is mixed with a binder. The binder is a paste consisting of wax

mixed with grease, paraffin, kerosene and turpentine. It is applied either on the buffing wheel or on the work. Buffing wheels are rotated against the work to get a superior finish.

Scraping

There will be always some minor imperfections on the machined surfaces. They are removed by using hand tool called scraper. There are three types of scrapers-flat, half-round and triangular. The part to be scraped is fitted in a vise and thin layer of Persian blue is applied on the surface. Thin flakes of metal are removed. Persian blue is once again applied to check the flatness.



Scraping

Electro plating

Electro plating is the process of applying metallic coatings on the surfaces of metal parts. It can be done on parts of non-metals also.

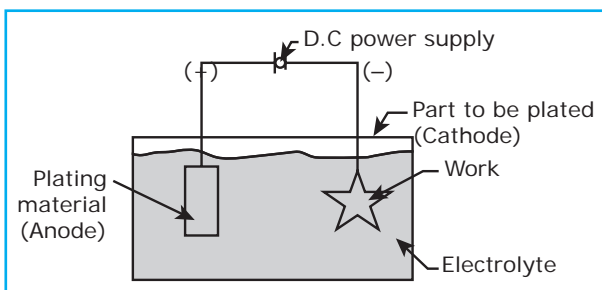

Electroplating

This is done for protection against corrosion or against wear and tear and far better appearance. It is also done to slightly increase the size of worn out parts and to make parts easy to solder. It may also be used to keep off selected areas on steel parts from being carburized during heat treatment.

Common plating materials are chromium, nickel, copper, zinc, cadmium, etc. The more precious metals like silver, gold, platinum and radium are also applied for plating. Door handles and automobile parts are chromium plated for appearance. The method of plating a layer of zinc is known as galvanizing.

Surface to be plated must be buffed smooth to eliminate scratches. The surface is cleaned by suitable cleaning solutions to remove all grease and dirt.

The four essential elements of a plating process are the cathode, anode, electrolyte and direct current. The current leaves the anode, which is a bar of plating metal and migrates through the electrolyte to the cathode which is the part to be plated.

4.17 Safety precautions

1. We should ensure that the work is held firmly and properly. The grinding wheel should be inspected and mounted on the spindle.
2. Proper work speed, wheel speed and table feed should be selected according to the nature of the work.
3. Safety goggles should be worn by the operator.
4. It should be checked whether the safety guards are fitted.

5. The operator should not touch the rotating work or the grinding wheel.
6. The operator should not wear loose shirts and neck tie.
7. The work rest of a bench grinder should be placed close to the grinding wheel.
8. The speed of the vitrified grinding wheels should not exceed 2000 meters per minute.
9. When new wheels are used, the wheels should be kept minimum.

ACTIVITY

1. Arrange the students to visit nearby industry, to demonstrate about the different types of grinding machines and its operation.

10. If the job is in a magnetic chuck, extra grips should be placed around the work pieces.

Questions

Part I.

Choose the correct option 1 Mark

1. The accuracy obtained by precision grinding is
 - a. 0.000025 mm
 - b. 0.0025 mm
 - c. 0.00125 mm
 - d. 0.00625 mm
2. The cutting tool with several thousands of cutting edges is
 - a. Lathe cutting tool
 - b. Drill
 - c. Grinding wheel
 - d. Milling cutter
3. The heat generated during dry grinding will be
 - a. 2000°C
 - b. 20°C
 - c. 1000°C
 - d. 1200°C



4. Bond used for making elastic grinding wheel is
 - a. Vitrified
 - b. Silicate
 - c. Shellac
 - d. Resinoid
5. The grip with which the bond holds the abrasives is known as
 - a. Grain size
 - b. Grade of the grinding wheel
 - c. Structure of the grinding wheel
 - d. Type of abrasive

Part II.

Answer the following questions in one or two sentences 3 Marks

6. What is meant by grinding?
7. Name any four types of grinding machines.
8. What is meant by centreless grinding?

9. What are the four types of surface grinders?
10. List out any four operations performed in a grinding machine.
11. What are the effects of dry grinding?
12. Mention any four types of bonds used in grinding wheel.
13. What is meant by “glazing”?
14. What is meant by “Loading” in a grinding wheel?
15. What are the reasons for chattering?

Part III.

Answer the following questions

in about a page

5 Marks

16. List out the various types of non-precision and precision grinding machines.
17. Explain the external centreless grinding machine with neat sketch.
18. A grinding wheel is specified as follows WA46K5V17. Explain the meaning of each symbol.

19. Explain with neat sketch of “Truing of a grinding wheel”.
20. Explain “Dressing” of a grinding wheel with a diagram.
21. Write short notes on
 - a. Lapping
 - b. Honing

Part IV.

Answer the following Questions in

detail.

10 Marks

22. Sketch and explain important parts of an external cylindrical grinder.
23. Sketch and explain a surface grinder.
24. Explain ‘mounting’ of a grinding wheel with a suitable diagram.
25. Write notes on
 - a. Precision grinding
 - b. Polishing
 - c. Buffing
 - d. Scraping

Milling Machine



Learning Objectives

- Students to know about the inventor of milling machine merits and demerits of it. Isometric view of milling machine, important parts and milling operations.
- To understand, types of milling machine and their explanation, difference between plain and universal milling machine.
- To know about the size of the milling machine, basic milling process, work-holding devices and tool-holding devices in milling machine.
- To understand about the cutting speed, feed depth in milling machine and the structure of indexing head, its working principle, indexing method and safety precautions for milling machine.



Ellarkkum nandraam panidhal avarullum
Selvarkkae selvam thakaiththu. –Kural 125

Humility is good in all, but especially in rich it is (the excellence of) higher riches.

CONTENTS

- | | |
|---|---|
| 5.1 Introduction of milling machine | 5.11 Isomeric view of milling cutters |
| 5.2 Horizontal milling machine | 5.12 Standard milling cutters |
| 5.3 Vertical milling machine | 5.13 Elements of plain milling cutter |
| 5.4 Types of milling machine | 5.14 Milling cutter materials |
| 5.5 Differences between plain milling machine and universal milling machine | 5.15 Milling machine operations |
| 5.6 Size of milling machine | 5.16 Cutting speed, feed and depth of cut |
| 5.7 Fundamentals of milling | 5.17 Indexing head |
| 5.8 Work – holding devices | 5.18 Construction of indexing head |
| 5.9 Cutter holding devices | 5.19 Indexing methods |
| 5.10 Milling machine attachments | 5.20 Safety precautions |



Milling machine was invented by Eli Whitney in 1818.

In 1861, it was developed by Brown & sharp, Joseph R. Brown to provide various special features of the machine.



5.1 Introduction

Milling is a process of removing metal by feeding the work against a rotating multipoint cutter. The machine tool intended for this purpose is known as milling machine.

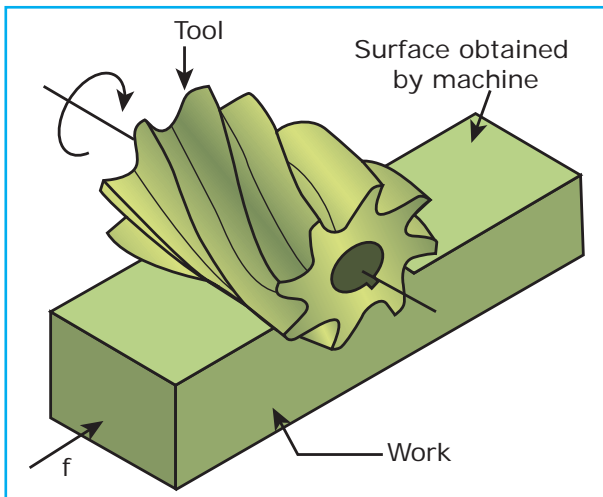

It is found in shops where tools and cutters are manufactured. The surface obtained by this machine tool is superior in quality and more accurate and precise. Eli Whitney designed a complete milling machine in 1818. In the year 1861 Joseph Brown, a member of Brown and Sharp Company developed the first universal milling machine.

Advantages

1. The metal is removed at a faster rate as the cutter has got multiple cutting edges and rotates at a higher speed.

2. It is possible to perform machining by mounting more than one cutter at a time.
3. The able of the machine can be moved to an accuracy of 0.02 mm.
4. It is very useful since various cutters and precise tools can be machined.
5. Special attachments can be mounted on the machine to perform operations that are performed in other machine tools.

Disadvantages

1. The cost of the milling machine is high.
2. As milling cutters cost high, the investment for procuring tools is more.
3. The production cost will increase if we carry out the operations performed in a shaper or a drilling machine with a milling machine.

5.2 Horizontal Milling Machine

Base

It is made of cast iron and supports all the other parts of the machine tool. A vertical column is mounted upon the base. In some machines, the base serves as a reservoir for cutting fluid.



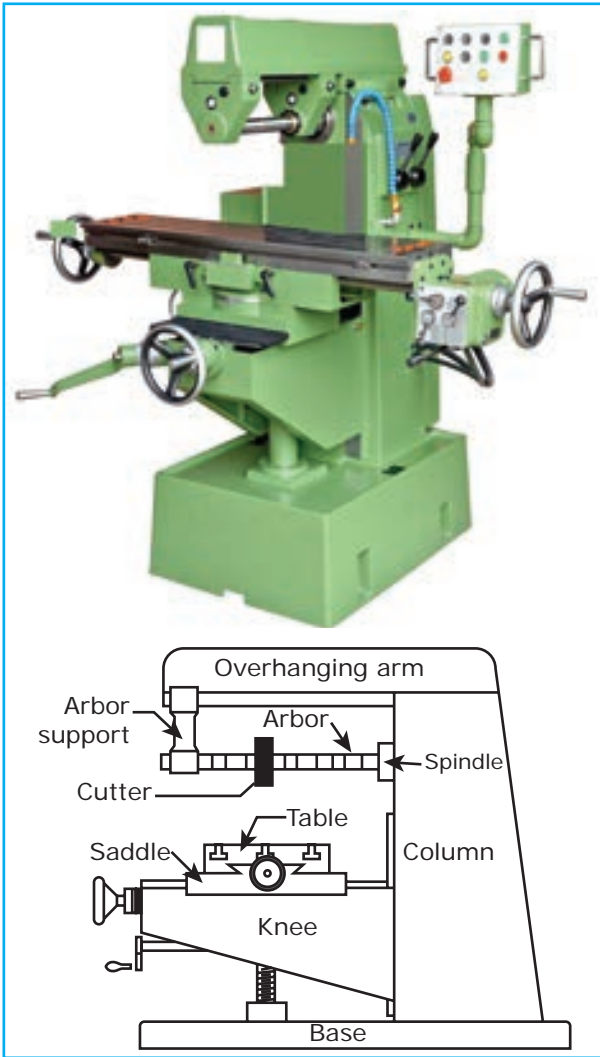

Horizontal Milling Machine

Saddle

It is mounted on the guideways of the knee and moves towards or away from the face of the column. This movement can be obtained either by power or by hand. The top of the saddle has guideways for the table movement.

Table

The table is moved longitudinally either by power or manually on the guideways of the saddle. The trip dogs, placed on it, control the movement of the table. The table of a universal milling machine can be swiveled horizontally to perform helical works. The top surface of the table has got 'T' – slots on which the workpieces or other work holding devices are mounted.

Spindle

It is located in the upper part of the column. It receives power from the motor through belt, gears and clutches. The front end of the spindle has got a taper hole into which the cutters are held with different cutter holding devices.

Column

It is mounted upon the base and it is box shaped. It houses the mechanism for providing drive for the spindle. The front vertical face of the column is machined accurately to form dovetail guideways for the knee to move up and down. The top of the column holds an overhanging arm.

Knee

It slides up and down on the guideways of the column. An elevating screw mounted on the base obtains this movement. Saddle is mounted upon the knee and moves in a crosswise direction.

Over arm

It supports the arbor from the top of the column. The arbor is supported by the bearing fitted within the arbor support. It is also useful while using some special attachments.

Arbor

It supports the different types of cutters used in the machine. It is drawn into the taper hole of the spindle by a draw bolt. One or more cutters are mounted on the arbor by placing spacing collars between them. The arbor is supported by an arbor support. The arbor is provided with a morse taper or self-releasing taper.

A column and knee type milling machine is illustrated in fig.

5.3 Vertical milling machine

It is very similar to a horizontal milling machine in construction as it has the same parts of base, column, knee, saddle and table. The spindle of the machine is positioned vertically. The cutters are mounted on the spindle is rotated by the power obtained from the mechanism placed inside the column. Angular surfaces are machined by swiveling the spindle head.

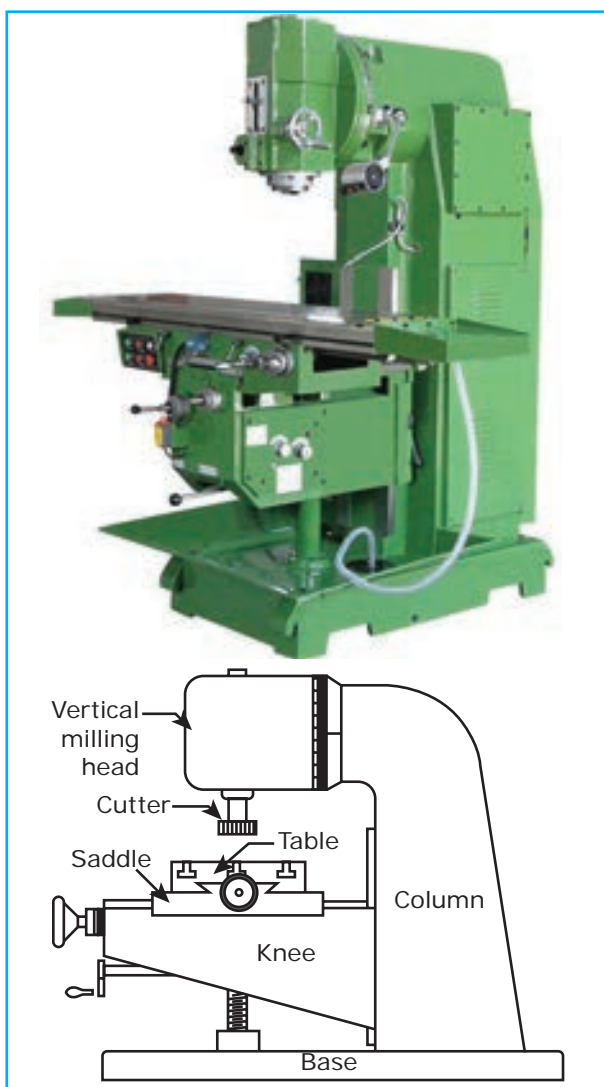

Vertical milling machine

5.4 Types of milling machine

The milling machines are classified according to the general design of the machine.

1. Column and knee type
 - a. Plain milling machine
 - b. Universal milling machine
 - c. Omniversal milling Machine
 - d. Vertical milling machine
2. Table types milling machine
3. Planer type milling machine
4. Special type milling machine

Column and knee type milling machine

The column of a column and knee type milling machine is mounted vertically upon the base. Knee is mounted on the accurately machined guideways of the column. It is designed to move up and down accurately. Saddle and table are mounted on the knee.

There are different types of column and knee type machines.

a. Plain milling machine

It is rigid and sturdy. Heavy workpieces are mounted and machined on the machine. The work mounted on the table is moved vertically, longitudinally and crosswise against the rotating cutter. The table cannot be rotated. It is also called as horizontal milling machine because the cutter rotates in horizontal plane.

b. Universal milling machine

The table of a universal milling machine can be swiveled by 45° on either side and so helical milling works can be performed.

It is named so because it can be adapted for a very wide range of milling operations.

Various milling attachments like index head, vertical milling head, slot milling head and rotary table can be mounted. It can be machine drills reamers, gears, milling cutters with a very high degree of accuracy and so it finds an important place in workshop.

c. Omniversal milling machine

In addition to the table movement obtained in a universal milling machine, the knee can be fitted to a required angle. It is useful for machining helical grooves,

reamer and bevel gears. It is mostly used in tool room work.

d. Vertical milling machine

A spindle of a vertical milling machine is positioned at right angles to the table. The cutter is moved vertically or at an angle by swiveling the vertical head of the machine.

The machine is adapted for machining slots and flat surfaces by moving the table. By mounting end mills and face milling cutters on the spindle, vertical milling and internal milling are preformed.

5.5 Differences between a plain milling machine and a universal milling machine

S.No.	Plain milling machine	Universal milling machine
1.	The table can be moved vertically, longitudinally and crosswise.	Apart from the three movements of a plain milling machine. It can be swiveled about 45°.
2.	Helical milling works cannot be done as the table cannot be swiveled.	The table can be swiveled and helical milling and spiral milling can be performed.
3.	As there are no special attachments, operations like gear cutting, slotting and vertical milling operation cannot be performed.	Special attachments like indexing head, rotary table, vertical milling attachment, slotting head are available with this machine.
4.	It is more rigid and suitable for machining on heavy and large workpiece and for simple milling operations.	It is meant for light workpieces, a wide range of operations can be performed in this machine. It is mainly used in tool rooms.
5.	The cost is less.	It is very costly.

5.6 size of a milling machine

The size of a milling machine is specified as follows

1. The size of the table (Length and width)
2. The maximum lengths of longitudinal, cross and vertical travel of the table.

3. Number of spindle speeds, number of feeds.
4. Spindle nose taper.
5. Power required
6. Nett weight of the machine
7. The floor space required
8. Type of the machine

5.7 Fundamental milling process

The various milling process may be grouped under two headings

1. Peripheral milling
2. Face milling

Peripheral milling

The machining is performed by the cutting edges on the periphery of the milling cutter. It is classified under two headings.

1. Up milling
2. Down milling.

Up milling

In this method, the workpiece mounted on the table is fed against the direction of rotation of the milling cutter. The cutting force is minimum during the beginning of the cut and maximum at the

end of cut. The thickness of chip is more at the end of the cut. At the cutting force is directed upwards. It tends to lift the workpiece from the fixtures. A difficulty is felt in pouring coolant on the cutting edge. Due to these reason the quality of the surface obtained by this methods is wavy. This processes being safer is commonly used and sometimes called conventional milling.

Down milling

The workpiece mounted on the table is moved in the same directions as that of the rotation of the milling cutter. The cutting force is maximum at the beginning and minimum at the end of cut. The chip thickness is more at the beginning of the cut the workpiece is not disturbed because of the bite of the cutter on the work. The coolant directly reaches to the cutting point. So the quality of surface finish obtained is high. Because of the backlash error between the feed screw of the table and the nut, vibration is set up on the workpiece.

Face milling

During face milling, the machining is performed by the peripheral cutting edges. The surface obtained by the processes is perpendicular to the axis of rotation of the cutter.

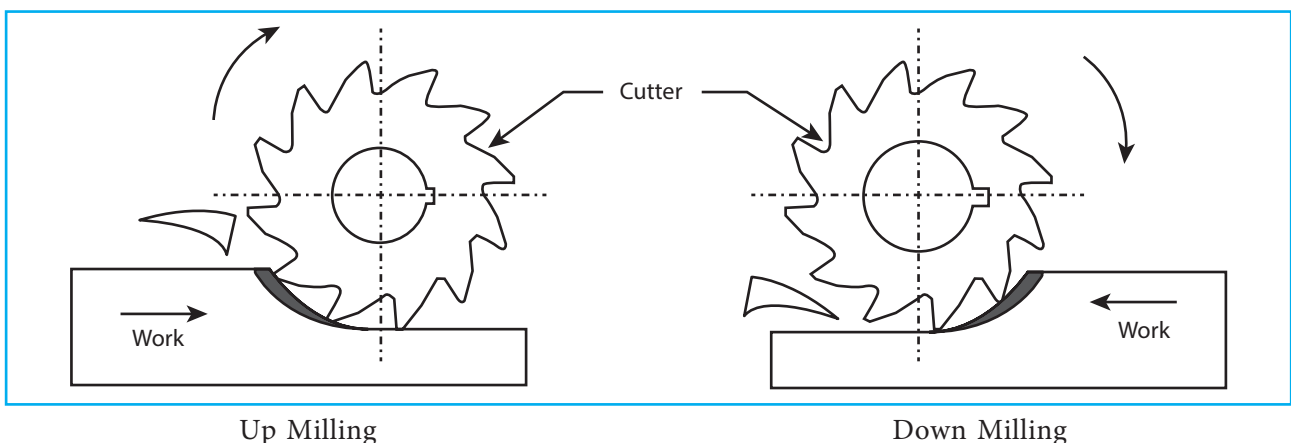

Up Milling

Down Milling

End milling

End milling is a process of the machining by milling cutters which have cutting edges both on the end face and on the periphery.

5.8 Work holding devices

For effective machining operations, the workpieces need to be properly and securely held on the machine table. The following are the usual methods of holding work on the table. Large and irregular shaped workpieces are held on the milling machine table by 'T' -bolts and clamps. 'V' - blocks are used for holding cylindrical workpieces on the machine table in which key ways, slots and flats are to be machined. Angle plates are used to support the work when surfaces are to be milled at right angles to another machined surfaces.

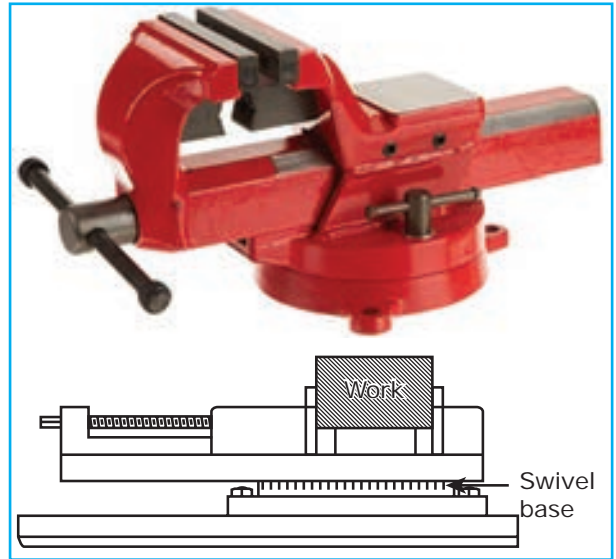

Swivel Vise

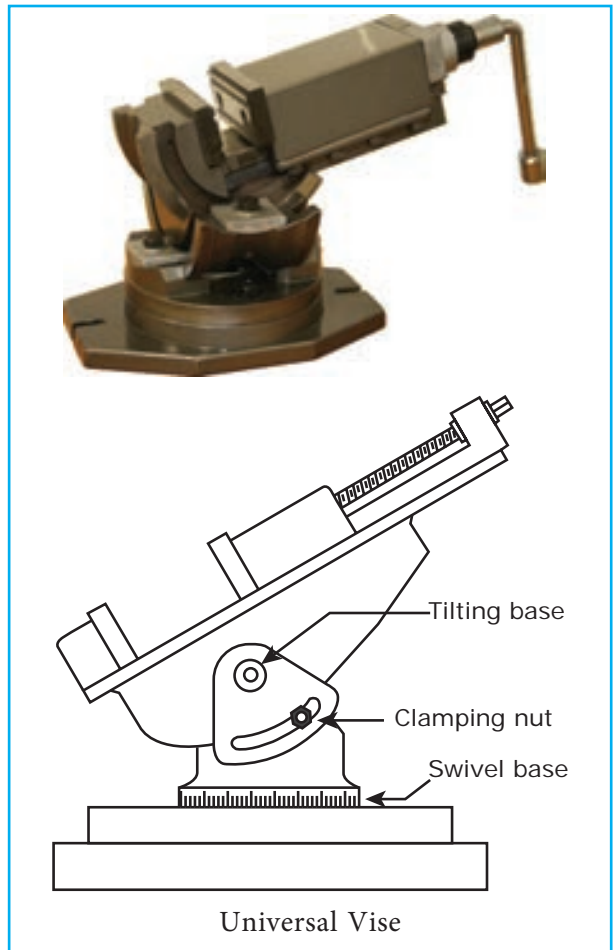

Universal Vise

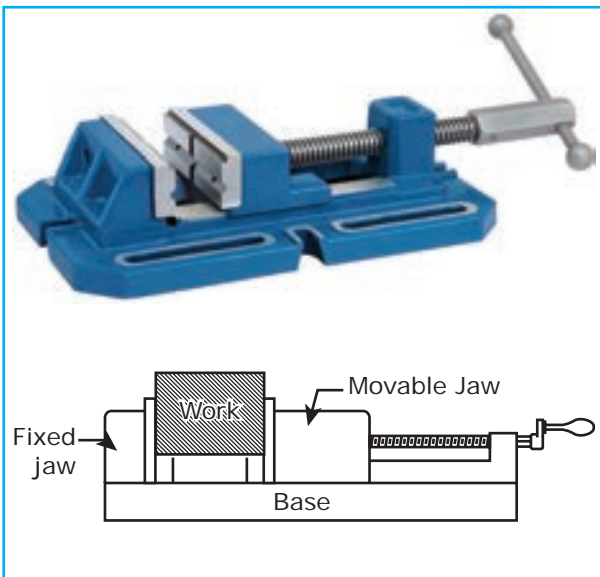

Plain Vise

Vises are commonly used for holding work on the table due to its quick loading and unloading arrangement. There are mainly three types of vises namely plain vise, swivel vise and universal vise.

Milling fixtures are useful when large numbers of identical workpieces are to be machined workpieces are held easily, quickly and accurately by milling fixtures.

5.9 Cutter holding devices

Depending on the design of the cutter there are several methods of supporting milling cutters on the machine spindle.

1. Arbor
2. Collet
3. Adapter
4. Screwed on cutters

Arbor

Milling cutters with central holes are mounted and keyed on a shaft called arbor. There are three different types of arbor namely pilot end arbor, 'A' type arbor and stub arbor.

The arbours are made with taper shanks for correct alignment with the machine spindle the left side of the arbor is threaded internally to receive a draw bolt. This draw bolt connects the arbor with the spindle. A long key way is cut on the entire length of the arbor. Cutters are mounted at desired positions on the arbor by placing spacing collars between them. The spindle rotation is transmitted to the arbor and the cutter is rotated. An arbor is illustrated in figure



Arbor

Collet

It is form of sleeve bushing used to hold arbor or cutters having a smaller shank than the spindle taper. Collets are connected to the spindle by a draw bolt and the rotary motion is transmitted to the cutters.

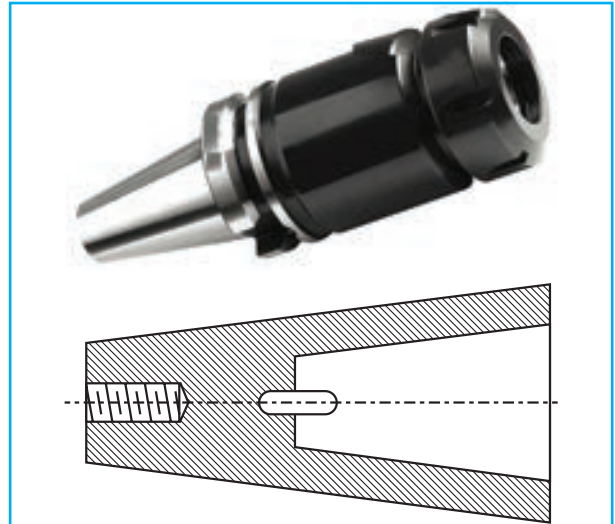

Collet

Adapters

Milling cutters having shanks are generally mounted on adapter. The outside taper of the adapter conforms to the taper hole of the spindle. The shank of the cutter fits into the taper hole of the adapter.

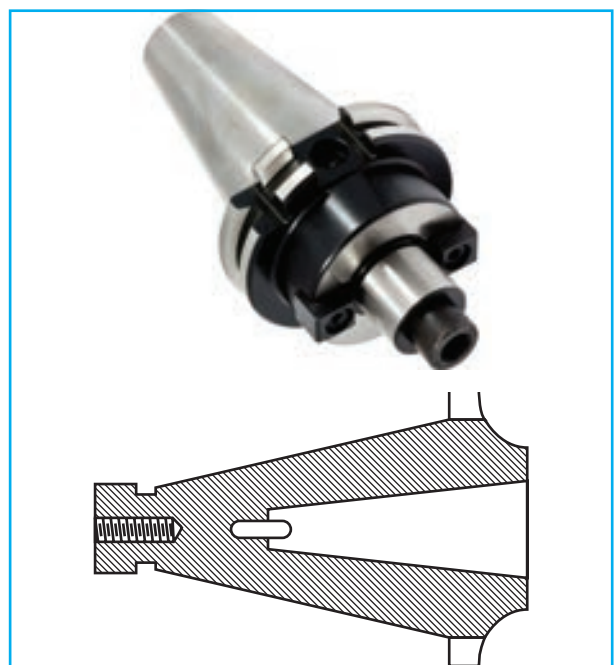

Adapter

Screwed arbor

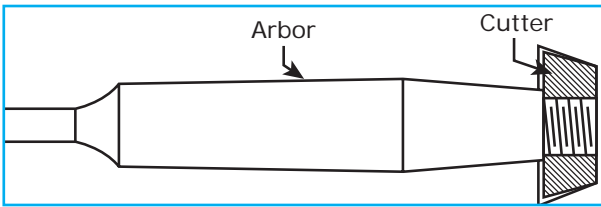

The small cutters having threaded holes at the center are held by screwed arbors. It has a threaded nose at one end and adapters shank at the other end the shank of the arbor is mounted on the spindle.

5.10 Milling machine attachments

Milling machine attachments are intended for purpose of developing the range of operations, versatility, production capacity and accuracy of machining process. The different milling machine attachments are

1. Vertical milling attachments
2. Universal milling attachments
3. High speed milling attachments
4. Slotting attachments
5. Rotary table attachments
6. Indexing head attachments



Vertical Milling Attachment

Vertical milling attachments

A horizontal milling machine is converted into a vertical milling machine by the vertical milling attachment. Vertical milling attachment is mounted on the face of the column of the horizontal milling machine. The attachment along with the spindle can be swiveled to any angle for machining angular surfaces.

Universal milling attachments

By having the universal milling attachments the spindle of the machine can be swiveled about two perpendicular axes. This arrangement permits two spindle axis to be swiveled at practically any angle to machine any angular surface of the work.



Universal Milling Attachment

High speed milling attachment

This attachment is used to increase the regular spindle speeds by four to six times milling cutters of smaller diameters are operated efficiently at higher cutting speeds. This attachment is bolted to the face of the column and enables the cutter to be operated at speeds beyond the scope of the machine.



High Speed Milling Attachment

Slotting attachment

The rotary movement of the spindle is converted into reciprocating movement of the ram by a crank arrangement. This attachment makes the milling machine to be converted into a slotting machine by accepting a single point slotting tool. The tool is mounted on the ram and used for cutting internal or external keyways, spline etc. It can also be swiveled for machining angular surfaces.



Slotting attachment

Rotary table attachments

It is special device bolted on top of the machine table to provide rotary motion to the workpiece in addition to the longitudinal cross and vertical movements of the table. It consists of a circular table provided with 'T'- slots mounted on a graduated base. The driving mechanism of this attachment is made possible by worm and worm gear.



Rotary Table Milling Attachment

Indexing head attachment

It is a special work holding device used for dividing the periphery of the work into any number of equal divisions. The work is held in a chuck of the dividing head spindle or supported between



Indexing head attachment

centres. It is also used in shaping machines and slotting machines. While machining gears, spirals, clutches and ratchets this dividing head is used to divide the circumference of the work into any number of equal parts.

5.11 Isometric view of milling cutters

Milling cutters are multipoint cutters. These cutters are used to remove excess material of given job by milling

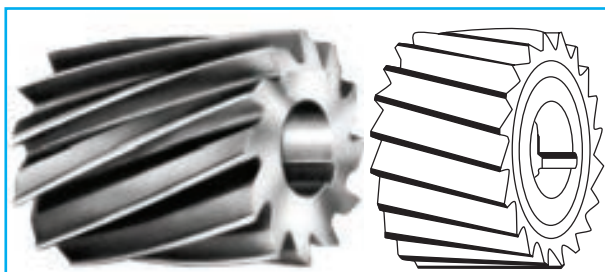

Isometric view of milling cutters

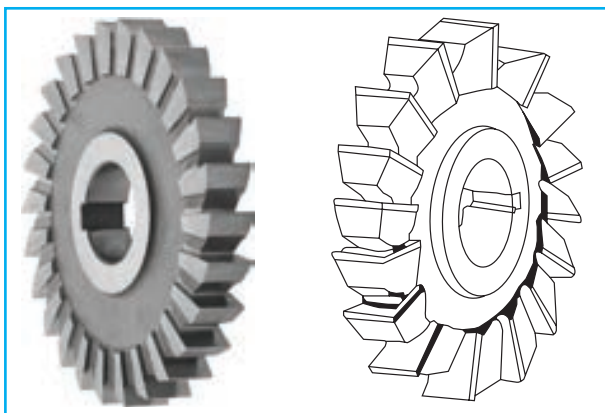

Milling cutters

5.12 Standard Milling Cutter

There are different types of milling cutters used in a milling machine. A suitable milling cutter is selected according to the need.

Plain milling cutter

Plain milling cutters are cylindrical in shape and have teeth on the circumferential surface only. They are used for producing

flat surfaces parallel to the axis of rotation of the spindle. The teeth of the cutter may be straight or helical according to the size. If the width of the cutter is more, it is called as slabbing cutter in order to be mounted on the arbor. Plain milling cutters have nicked teeth to break the chips into small pieces. Helical plain milling machine cutters are superior to a straight plain milling cutter.

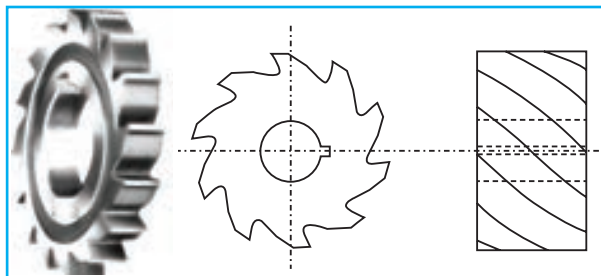

A plain milling cutter

Side milling cutter

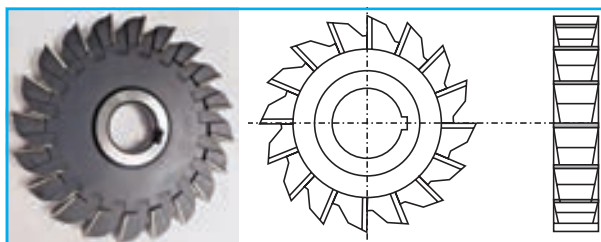

Side milling cutter

Side milling cutters have teeth on its periphery and also on one or both of its sides. They are intended for removing metal from the sides of the workpiece. There are different types of side milling cutters namely face and side milling cutter, half side milling cutter, staggered teeth side milling cutter and inter locked side milling cutter. Machining is performed by selections a proper milling cutter.

Metal Slitting saw

It is intended for cutting narrow, deep slots and for parting off operation. The teeth are cut on the circumference of the cutter. The width of the cutter ranges

from 0.75 mm to 7 mm. The side of the cutter is relieved so that side may not rub against the work.

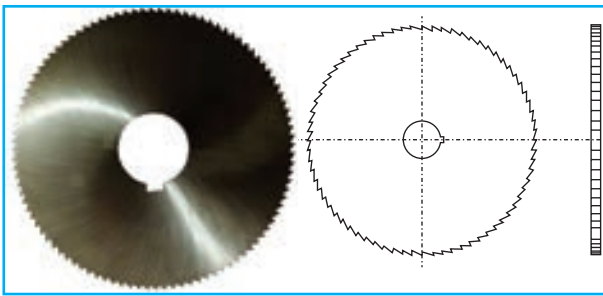

Metal slitting saw

Angle milling cutters

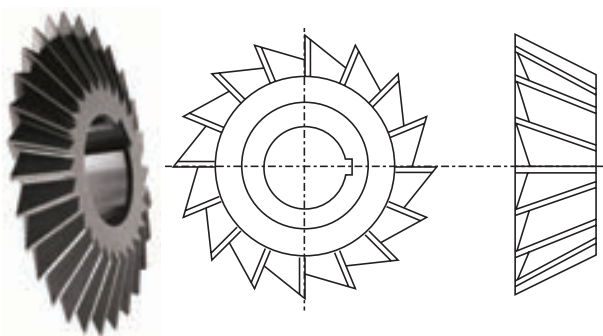

The teeth of the angle milling cutter are not parallel to the axis but are at an angle to it. By using angle milling cutter, inclined surfaces, bevels and helical grooves are machined. There are two types of angle milling cutter single angle milling cutters and double angle milling cutter.

'T' – Slot milling cutter

It is a special form of end mills intended for machining 'T' slots. It looks like a side milling cutter with a shank. The cutters have cutting teeth on the periphery as well as on both sides of the cutter.

End mill Cutter

These cutters have cutting teeth on the end as well as on the periphery of the cutter. It is made of two parts – body

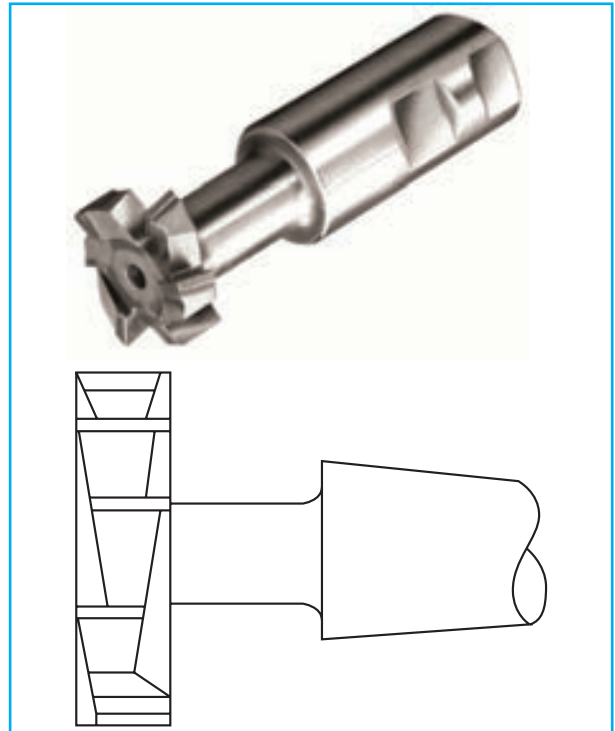

'T' – Slot milling cutter

and shank. The shanks of the cutter may be straight or taper. If the cutter doesn't have a shank it is called shell end milling cutter. These cutters are useful in machining long narrow slots, holes and flat surface.

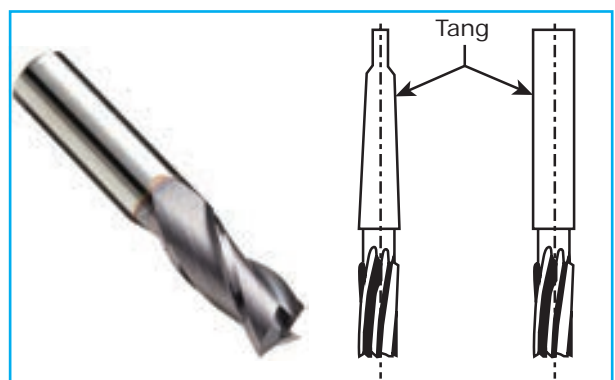

End milling cutters

Flying cutter

Flying cutter is the simplest form of cutter. It consists of a single point cutting tool attached to the end of the arbor. The cutting edge may be formed to reproduce a contoured surface. They are used when standard cutters are not

available. The work is done very slowly because of a single cutting edge. A flying cutter is shown in Figure.

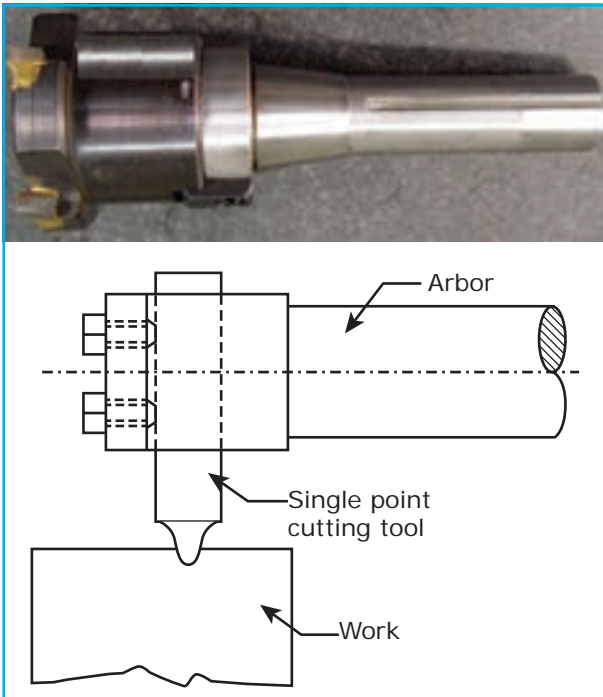

Flying cutter

Form cutter

Form cutters have irregular profiles on their cutting edges to produce required

outlines on the work. Concave and convex milling cutters are used to produce convex and concave surfaces respectively using gear milling cutters. Gears are machined corner round milling cutters are used for cutting a radius on the edges of the work with the help of thread milling cutter threads are milled on a specific form and size. Tap and reamer cutter are used for producing grooves or flutes in tap and reamers.

5.13 Elements of a plain milling

Cutter

The main parts and angles of a plain milling cutter as shown in Figure.



Body of cutter

It is the part of the cutter left after exclusion of the teeth.

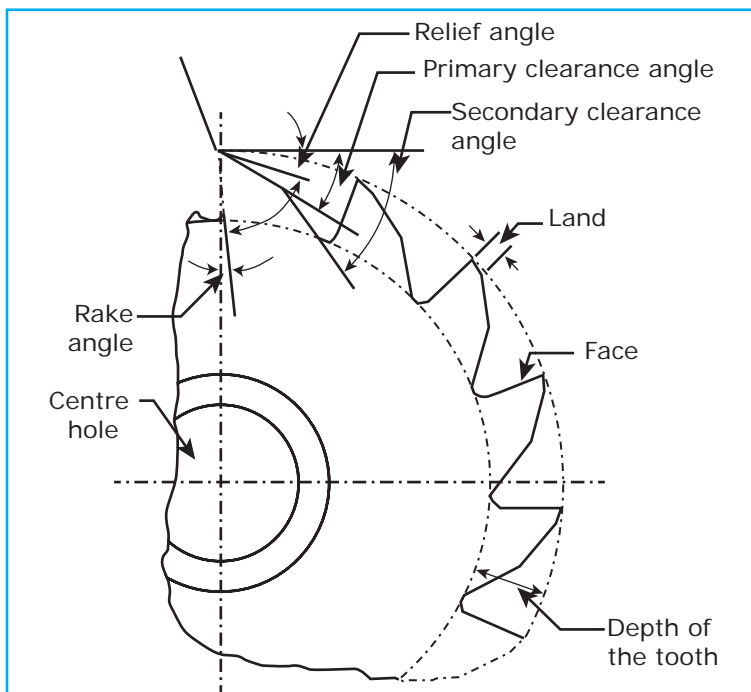

Elements of a plain milling cutter

Face

The portion of the teeth next to the cutting edge is known as face.

Land

The relieved back portion of the tooth adjacent to the cutting edge. Its value is approximately 1.5 mm. It is relieved to avoid interference between the surface being machined and the cutter.

Outside diameter

The diameter of the circle passing through the peripheral cutting edges.

Centre hole

It refers to hole present at the centre of cutter. A keyway is cut inside the hole.

Cutter angles

Relief angle

It is the angle between land of the tooth and the tangent to the outside diameter of the cutter at the cutting edge of the particular tooth. (Approx 7.5°)

Primary clearance angle

It is the angle between the back of the tooth and the tangent drawn to the outside diameter of the cutter at the cutting edge (Approx 15°).

Secondary Clearance Angle

It is the angle formed by the secondary clearance surface and the tangent to the periphery of the cutter at the cutting edge.

Rake angle

The angle measured in the diametral plane between the face of the tooth and a radial line passing through the cutting edge of the tooth. The rake angles may

be positive, negative or zero. If the face and the tooth body are on the same side of the radial line and the tooth body may be on opposite sides of the radial line. Then the rake angle is negative. If the radial line and the tooth face coincide in the diameter plane the rake angle is zero.

5.14 Milling cutter material

The milling cutters are generally made of the following materials.

1. Tool steel – High Speed Steel (HSS)
High Carbon Steel (HCS)
2. Cemented carbide
3. Stellite

In general shop work, the high speed steel cutters are most widely used.

5.15 Milling machine operations

The following operations are performed using suitable milling cutters

Horizontal milling

It is the operation of production of a flat surface parallel to the axis of rotation of the cutter. It is also called as slab milling, plain milling cutters and slab milling cutters are used to perform this operation.

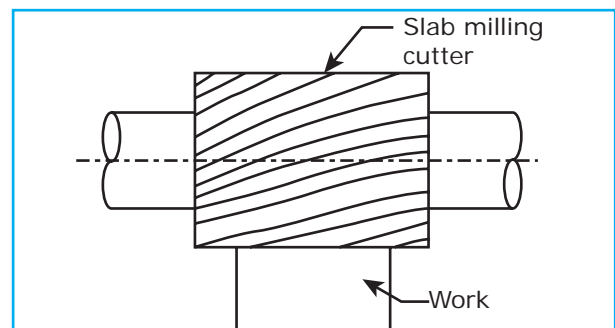

Horizontal milling

Face milling

The face milling is the operation performed by the face milling cutter rotated about an axis at right angles to the work surface. End mills and side & face milling cutters are also used at times to perform this operation. The depth of cut is provided to the table.

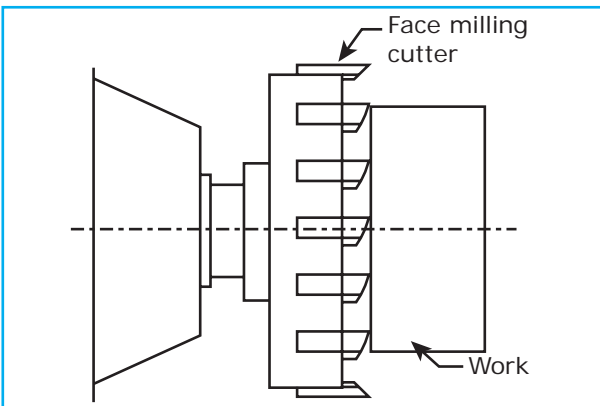

Face milling operation

Side milling

Side milling is the operation of machining a vertical surface on the side of a work piece by using a side milling cutter.

Straddle milling

It is the operation of production of two vertical surfaces on both sides of the work by two side milling cutters mounted on the same arbor. By using suitable spacing collars, the distance between the

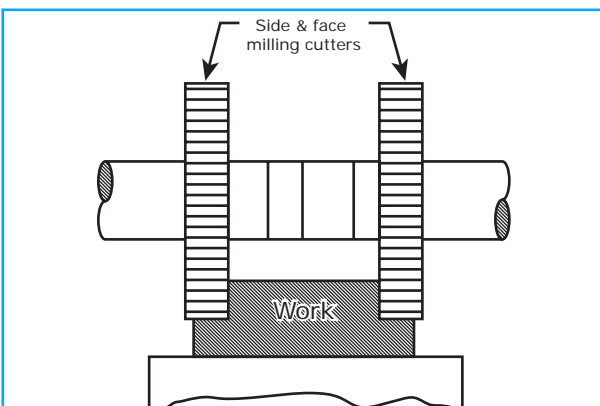

Straddle milling operation

two cutters are adjusted correctly. The straddle milling is commonly used to produce square or hexagonal surface.

Angular milling

Production of an angular surface on a workpiece other than at right angles to the axis of the milling machine spindle is known as angular milling. Example of angular milling is the production of the 'V' blocks.

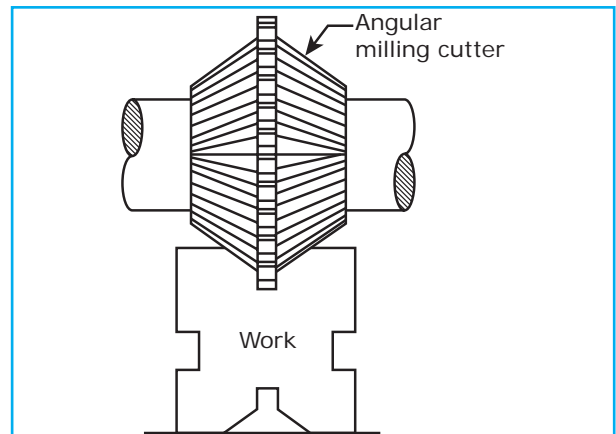

Angular milling operation

Gang milling

It is the operation of machining several surfaces of work simultaneously by feeding the table against a number of cutters (either of same type or of different type) mounted on the arbor of the machine. This method saves much of machining time and mostly used in production work.

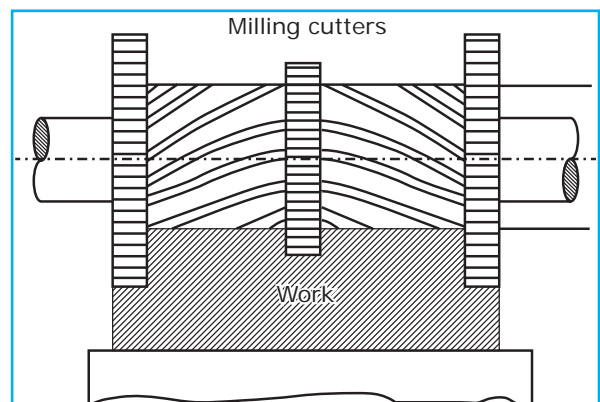

Gang milling operation

Form Milling

The form milling is the operation of production of irregular contours by using from cutters. Machining convex and concave surfaces and gear cutting are some examples of form milling.

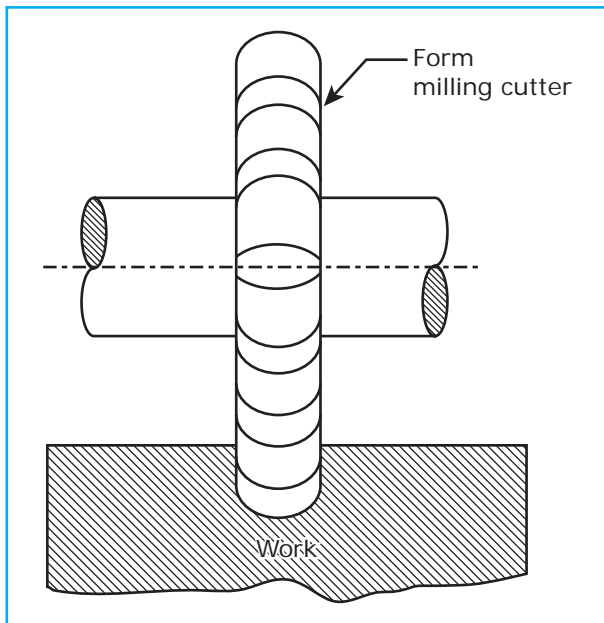

Form milling operation.

End milling

It is the operation of producing a flat surface which may be vertical, horizontal or at an angle to the table surface. The end milling is performed by a cutter known as an end mill. End milling is mostly performed in a vertical machine.

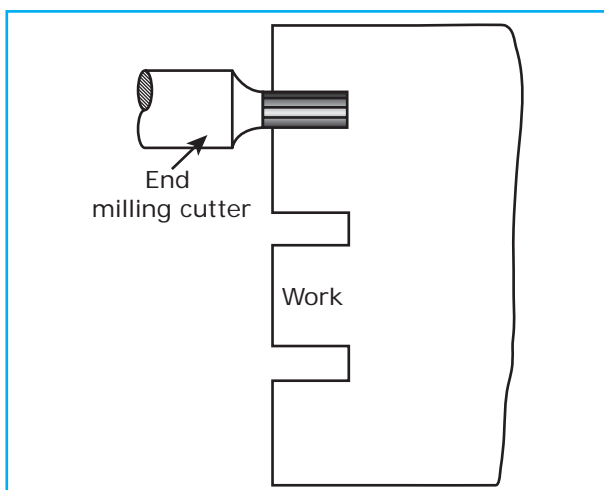

End milling operation

Keyway milling

The operation of production of keyways, grooves and slots of different shapes and sizes can be performed in a milling machine by using a plain milling cutter, a metal slitting saw, an end mill or by a side milling cutter.

Gear cutting

Gear cutting operation is performed in a milling machine by using a form cutter. The work is held between centers on a universal dividing head. A proper gear cutter is selected and the teeth are cut by DP, module method.

Cam milling

Cam milling is the operation of producing cams in a milling machine with the use of a universal dividing head and a vertical milling attachment. It is performed by end mills on the cam blank.

5.16 Cutting speed, feed and depth of cut

Cutting speed

It is the distance travelled by a point on the cutting edge of the milling cutters to remove metal in time duration of one minute. It is expressed in meters per minute.

$$\text{Cutting speed} = \frac{\pi dn}{1000} \text{ meter/minute}$$

$$\pi = \frac{22}{7} \text{ (or) } 3.14,$$

Where, D = The diameter of the milling cutter in mm

N = Spindle speed in rpm.

The cutting speed depends upon the material to be machined, the cutter

material, depth of cut, feed, type of operation and the coolant used.

Example

Calculate the cutting speed to perform milling with a cutter of diameter 60 mm and spindle speed of 250 rpm.

Solution

Given Diameter of cutter (D) = 60 mm

Spindle speed (N) = 250 rpm

$$\text{Cutting speed} = \frac{\pi dn}{1000} \text{ meter/minute}$$

$$\begin{aligned} \pi &= \frac{22}{7} \text{ (or) } 3.14, \\ &= \frac{22}{7} \frac{60}{1000} \frac{250}{1000} \\ &= 47.14 \text{ metre/minute} \end{aligned}$$

Feed

The feed in a milling machine is defined as the distance the workpiece advance under the cutter. Feed can be expressed in three different methods.

- 1. Feed per teeth:** It is the distance the work advances in time between engagements by the two successive teeth. It is expressed.
- 2. Feed per cutter revolution:** It is the distance the work advance in the time when the cutter turns through one complete revolution. It is expressed in mm per revolution of the cutter.
- 3. Feed per minute:** It is the distance the work advances in one minute. It is expressed in mm per minute. The feed in a milling machine depends on the material to be machined, cutter material, depth of cut, cutting speed, type of operation and the rigidity of the machine.

Depth of cut

The depth of cut is the thickness of the material removed in one pass of the work below the cutter. It is expressed in mm.

5.17 Indexing head

Indexing is the method of dividing the periphery of a piece of work into any number of equal parts. The attachment used for performing indexing is known as indexing head.

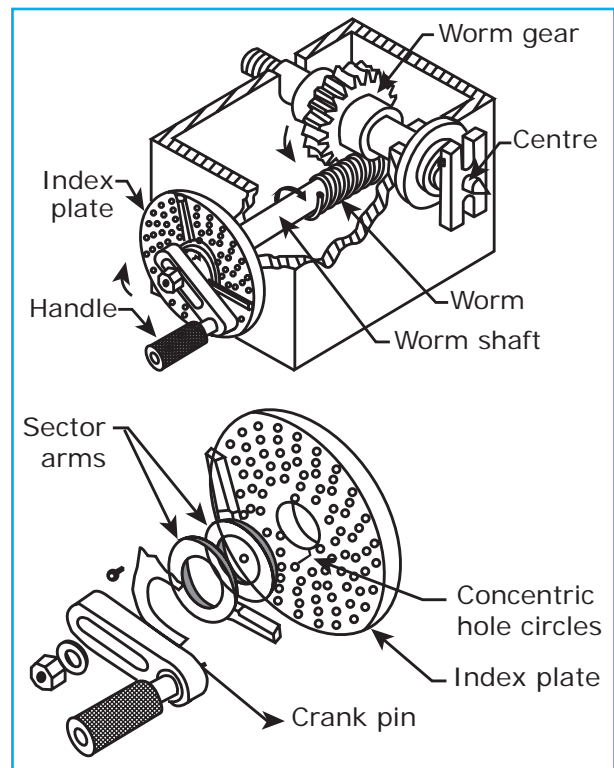

Indexing head

Uses of indexing

The indexing operation can be adapted for cutting gears, ratchet wheels, keyways, fluted drills, taps and reamers. The indexing head serves as an attachment for holding and indexing the work in during the above tasks. There are three different types of indexing heads namely

1. Plain or simple dividing head
2. Universal dividing head
3. Optical dividing head

5.18 Construction of indexing head

The construction of a universal dividing head as shown in figure and explained below.

Base

The base of the indexing head is fitted in the 'T' – slots of the milling machine table. It supports all the other parts of dividing head.

Spindle

The spindle is situated at the centre of the dividing head. It has a taper hole to receive a live center. The spindle is supported on a swiveling block, which makes the spindle to be tilted through any angle from 5° below horizontal to 10° beyond vertical. A worm wheel is mounted on the spindle. While doing direct or rapid indexing the index plate is directly fitted on the front end of the spindle nose.

Worm shaft

It is situated at right angles to the main spindle of the dividing head. A single threaded worm is mounted on the worm shaft which meshes with the worm wheel.

An indexing plate is fitted on the front end of the worm shaft and with the help of a handle, the worm shaft can be rotated to a pre determined amount.

Indexing Plate

It is mounted on the front end of the worm shaft. It is circular disk having different numbers of equally spaced holes arranged in concentric circles. The crank is positioned in the required hole circle and rotated through a calculated amount while indexing. The sector arm is used to eliminate the necessity of counting the holes on the index plate each time the index crank is moved.

Tail Stock

The work is held between the center of the spindle and the tailstock. It can be made slide and positioned at the required location.

Working principle of dividing head

When the crank is rotated with help of a handle through the required number of holes in the index plate. The work is rotated to required amount. This is possible because of the worm and worm wheel mechanism.

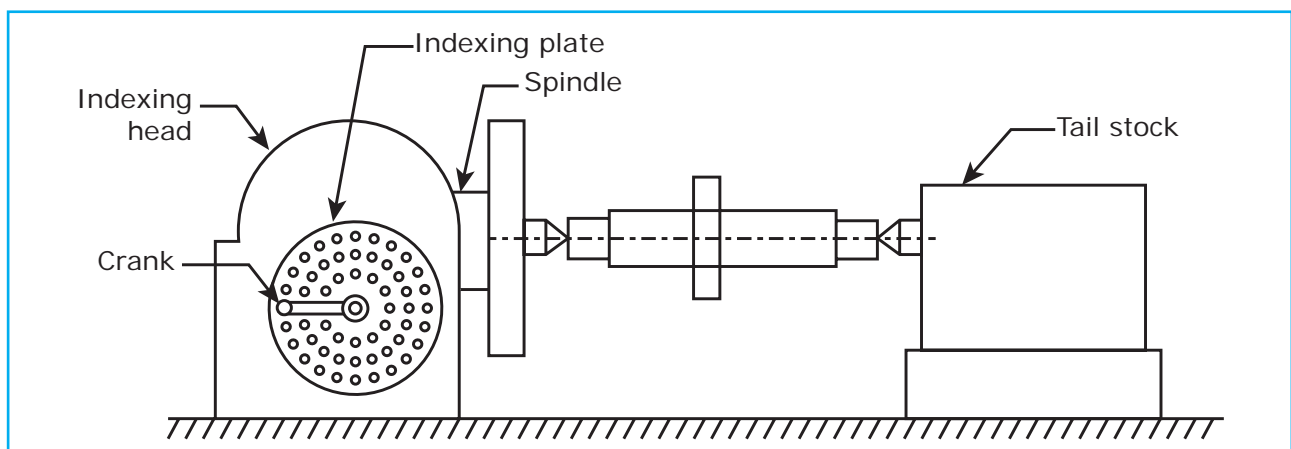

Construction of an indexing head

A gear train is arranged between the main spindle and the driven shaft when indexing is done by differential indexing method. The work is rotated as usual when the handle is rotated. At the same time, the index plate is also made to rotate a small amount through the gear train when indexing is by this differential indexing method, the index plate is released from the lock pin.

5.19 Indexing methods

There are several methods of indexing and they are

1. Direct or rapid indexing
2. Plain or simple indexing
3. Compound indexing
4. Differential indexing
5. Angular indexing

5.20 Safety precautions

Before operating the milling machine, the operator should know how to operate various controls of the machine. It should be ensured that the workpiece is held rigidly on the milling machine table. The cutter should not be in contact with the work even before the machining is commenced.

The spindle speed of machine should not be altered when the machine

is in operation. When the power of the machine table is on the arbor should not be removed or tightened. The operator should keep his body away from the rotating cutter. No steps should be taken to measure the workpiece while the cutter is cutting or revolving near the workpiece when the machine is in operation, safety guards should be placed in their position to prevent coolant and metal chips from spilling out.

The metal chips should be removed with suitable brushes and with bare hands. The operation should seek assistance from others while handling special attachments and heavy workpieces. The operator should always be present in person at the machine tool when the machine is in operation.

The machine tool should always be started and stopped by the operator himself. Danger's can be averted by handling the cutters with sharp cutting edges with great care. The machine tool should be kept clean. Milling cutters and measuring instruments should not be placed on the machine. The attention of the operation should always be focused on the task only. When troubles happen in the machine, they should be corrected with assistance of proper technicians in general safety should be ensured to the operator, the workpiece and the cutting tool.

ACTIVITIES

1. To arrange the students visit nearby industry and demonstrate the milling machine construction details and various kinds of operations.
2. To explain the different types of indexing methods with practical examples.

Questions

Part I.

Choose the correct option 1 Mark

1. Milling machine was developed by
 - a. Henry Maudslay
 - b. Eli Whitney
 - c. James Nasmith
 - d. Michael Faraday
2. In a milling machine, cutters are mounted on
 - a. Column
 - b. Spindle
 - c. Over hanging arm
 - d. Arbor
3. The distance of table-travel is controlled by
 - a. Saddle
 - b. Trip dogs
 - c. Cross-slide
 - d. Elevating Screw
4. The distance travelled by a point on a milling cutter in one minute is known as,
 - a. Cutting speed
 - b. Depth of cut
 - c. Spindle speed
 - d. Feed



Part II.

Answer the following questions

in one or two sentences 3 Marks

5. What is milling?
6. What are the types of milling machine?
7. How is the size of a milling machine specified?

8. Name the fundamental milling process?
9. What are the types of peripheral milling?
10. Name four work holding devices in a milling machine?
11. What is indexing?
12. What are the uses of indexing head?
13. What are the types of indexing head?
14. What are the methods of indexing?

Part III.

Answer the following questions in

about a page

5 Marks

15. What are the differences between a plain milling machine and a universal milling machine?
16. List out various milling machine special attachments.
17. List out various types of milling cutters.
18. Mention the different types of milling machine operations.

Part IV.

Answer the following Questions in

detail.

10 Marks

19. Draw a neat diagram of a milling machine and explain its construction.
20. Explain – up milling and down milling.
21. Explain any four cutter holding devices with diagram.
22. Draw a neat diagram of a plain milling cutter and explain its nomenclature.

Machine Tool Maintenance



Learning Objectives

- Students to understand the following maintenance of machine tools.
- To avoid the repair of machines, instruments, and machine parts.
- By using the maintenance tools, how to operate the machines.
- To increase the duration of life of the machines.



Seydhakka alla seyakkedum seydhakka
Seyyamai yaanum kedum. –Kural 466.

He will perish who does not what is not fit to do; and he also
will perish who does not do what it is fit to do.

CONTENTS

- | | |
|---|---|
| 6.1 Introduction | 6.10 Central maintenance department |
| 6.2 Purpose of Maintenance | 6.11 Types of maintenance |
| 6.3 Tear and wear | 6.12 Routine maintenance |
| 6.4 Back lash | 6.13 Daily maintenance |
| 6.5 Lubrication | 6.14 Weekly maintenance |
| 6.6 Important machine parts for lubrication | 6.15 Preventive maintenance |
| 6.7 Purpose of lubrication | 6.16 Breakdown maintenance |
| 6.8 Types of lubricant | 6.17 Capital repairs |
| 6.9 Types of lubrication | 6.18 Planned maintenance program |
| | 6.19 Instruments needed for maintenance |

DO YOU KNOW?

Spanner was invented by Solymen Merrick in 1835.



Solymen Merrick

inside the workshop and increase the production capacity.

All the machine tools are driven by electrical motors. It is necessary that the switches, fuse, the connections and other controls should be in order. Care should also be taken to keep in good conditions. The parts used for transmitting power from the motor – gears, chain drive, belt drive etc.

6.1 Introduction

“Prevention is better than cure”. With reference to this proverb, the task performed to make the machine tools work perfectly is called ‘Maintenance’. This is achieved by ensuring that machine tools cutting tools and measuring instruments function properly without any fault.

6.2 Purpose of ‘Maintenance’

The primary objective of the maintenance department is to ensure the machine tools, instruments, tools and accessories in good working condition. It is also necessary to ensure safety to both the machine tools and the operator. The accuracy and efficiency of the machine tools and the instruments are also to be maintained properly. By performing maintenance, we can avoid accidents

The rotating shafts of the machine tools are fitted with bearings and suitably supported by different types of brackets. As bearings are precision parts, we have to apply grease or any lubricating oil at recommended intervals to keep them in good operating conditions. The sliding parts of various machine tools should be maintained cleanly without any dirt on them. The metal chips should be cleaned at regular intervals.

The moving and rotating parts should be properly lubricated at the brackets where they are fitted.

The coolant pumps, filter elements, pipelines and valves should always be in good working condition.

The tools, accessories, special attachments and measuring instruments should be in good working conditions and be placed in their respective places.



6.3 Tear & Wear

Wear and tear

Due to continuous working of a machine tool and the nature of work performed on it, wear and tear is observed in the sliding parts of machine tools. As a result of this, the accuracy of the products is affected. In remedy, it is necessary to repair the said machine tools. The affected parts are to be replaced if necessary.

6.4 Backlash

Some slackness is observed in holding of parts, meshing gears or bolt and nut assembly. This slackness is known as backlash. If the amount of backlash is more in the case of mating gears, they should be replaced. The wear and tear on the gears should be observed once in a week time.

6.5 Lubrication

Rotating and sliding parts, which make contact with other parts, are subjected to wear due to friction. Viscous oil called lubricant is applied to these parts to avoid direct contact between them. The process of reducing friction is called lubrication.

Applying oil or grease to the axle shaft of the bullock cart and the cycle wheel, gearbox of automobiles, motor shafts of pumps, fans and sewing machine are some examples of lubrication.

Friction occurs as the shafts are rotating and the sliding parts moving on each other. It generates heat and the parts get damaged.

In order to keep the machine tools accurate and durable, it is necessary to apply lubricants between mating parts. It will reduce friction and wear is minimized.

Lubrication is the nerve centre of machine tool. As it is blood circulation for the human body, lubrication is for the machine tools.

6.6 The machine parts which need to be lubricated

1. Mechanisms of hydraulic systems
2. Guideways and sliding parts
3. Rotating shafts
4. Gear box
5. Feed Box
6. Speed changing mechanisms
7. Bearings

6.7 Purpose of of lubrication

1. Smooth functioning of sliding movable parts
2. To reduce friction and consequent wear
3. To remove burrs and dust
4. To reduce the heat generated due to friction
5. To prevent rust formation on precise parts
6. To provide cushioning effect to the load shocks
7. For hydraulic circuits to transmit power

6.8 Types of lubricants

The materials used for reducing wear between moving and sliding parts are called lubricants. Though there are many types of lubricants available, oil and grease are mostly used.



Grease

Grease is manufactured with the ingredients of soap and mineral oils. Different types of grease are manufactured for specific applications under different commercial names. So, it is necessary to know the specific type of grease to be applied for the specific part.

6.9 Types of lubrication

The different types of lubrication are

1. Ring lubrication
2. Wick Lubrication
3. Splash Lubrication
4. Grease Lubrication

Ring Lubrication

The method of lubrication involves a ring hanging from down the rotating

shaft. The bottom portion of the ring is immersed in the oil container. When the shaft starts rotating, the ring also rotates. While the ring rotates, it carries a small amount of oil and the oil is spread into the bearing and the shaft.

Wick lubrication

Wick lubrication is a method in which the wick along with a flexible thin piece of metal is used. A container having oil is placed above the bearing. The wick connects the container and the part to be lubricated. This lubrication enables the oil to flow from the container to the required place.

Splash lubrication

The rotating part of the machine itself is made to be immersed in the oil

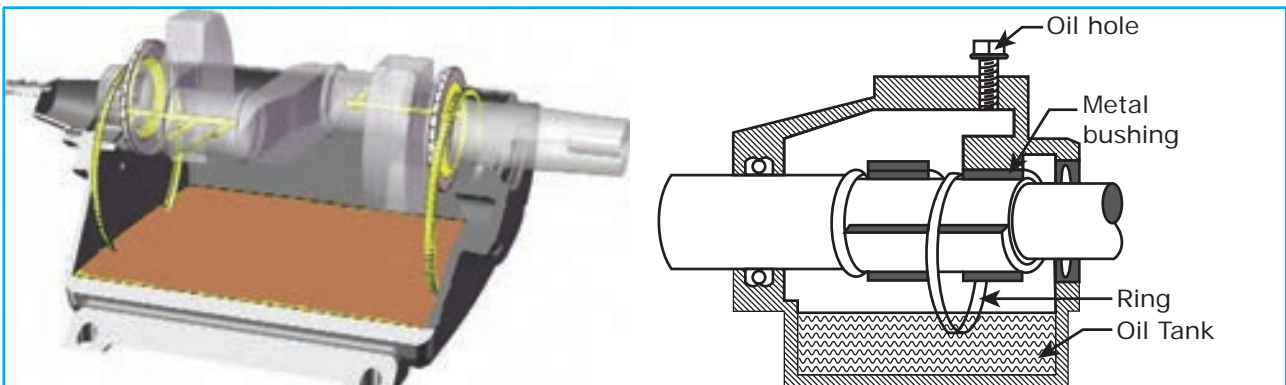

Ring Lubrication



Wick Lubrication

container. When the part starts rotating, the oil is splashed and the moving parts are lubricated. Bearings are generally lubricated by this method. Little spoons are attached to the rotating parts to get more quantity of oil to the part to be lubricated.

Grease lubrication

Grease lubrication is done with the help of grease guns. Another way of doing it simply is so fill a container with grease and the container is connected to the parts to be lubricated by means of a small tube. When a screw is screwed into the container, a good amount of grease is taken to the required place.

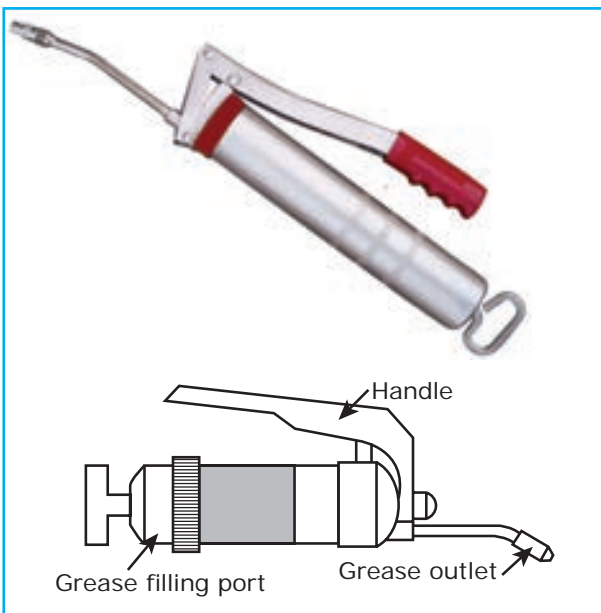

Grease gun

Lubrication oil and grease are manufactured under several trade names by the Indian oil companies. Suitable lubricants are used for specific purposes.

6.10 Central maintenance department

The primary aim of maintenance department is to ensure the machine

tools, instruments, tools and accessories in good working conditions. More maintenance attention is needed when the work load increases. If the machines are maintained properly, we can look out for more production.

Separate maintenance department will be functioning in major machine shops and industries. Experienced engineers, supervisors, technicians will be working in this department. Separate equipments and instruments will be used in the department.

6.11 Types of maintenance

There are different types of maintenance and they are



1. Routine maintenance
 - a. Daily maintenance
 - b. Weekly maintenance
2. Preventive maintenance
3. Breakdown maintenance
4. Capital repairs or Corrective maintenance

6.12 Routine maintenance

Routine maintenance is done to avoid unnecessary breakdown of machine tools. It involves regular works like cleaning and lubricating, making minor adjustments and doing small repair works.

It is important to chart out what are all to be done, daily, weekly and monthly.

6.13 Daily maintenance

1. Cleaning all the parts of the machine tool.

2. Lubricating the movable parts with grease and oil as per requirements.
3. To correct the machine tool to make it operate accurately.
4. To look at whether the coolant apply and auto lubricating equipments are working properly.
5. To remove the burrs cleanly.

6.14 Weekly maintenance

1. The measuring instruments, gauges and hand tools are checked and corrected if necessary.
2. The spare parts and integral parts of the machine tools should be cleaned.
3. The entire workshop premises should be maintained cleanly.
4. Grinding wheels of bench grinders and tool and cutter grinders should be dressed. The work rests of these machines should be adjusted properly.
5. The protective devices in the machine tool are checked whether they are properly fixed. And they are corrected if necessary.
6. The cables and electrical connections should be checked.
7. The position and working of belt, chain etc., are checked and adjusted.
8. Parts like gears, clutches and bearings are checked for their proper functioning.
9. The accuracy of precision measuring instruments are checked and corrected. They are also checked for zero error.

6.15 Preventive maintenance

In order to avoid sudden breakdown of machine tools and maintenance programme is charted out. This will ensure that there is no slip in the rate of production.

In case of any major breakdown to the machine tool, two types of losses are incurred to the management.

1. Direct losses
2. Indirect losses

- Direct loss is the expenditure incurred for repairing the machine tools and getting them back in action.
- Indirect losses happen by the loss of income for the disturbed production. The management has to pay the labourers their wages. It will also be earning a bad name due to non-deliverance of the products to its customers. So, it is necessary to plan the preventive maintenance program to avoid such losses.

Even if the machine tools are working in proper conditions, it is better to stop production once in a while to make the necessary repairs and adjustments. Certain parts should be replaced if necessary.

6.16 Breakdown maintenance

Even after enforcing routine maintenance and preventive maintenance, there are chances that some machine parts may fail due to some reason or other. In order to bring back the machine to its original working condition, some minor or major repairs are needed to be done. This type of maintenance is known as breakdown maintenance.

6.17 Capital Repairs (or) Corrective maintenance

Even if the machine is functioning properly, it is necessary to halt the functioning of the machine to do some major repair once in a year. To do that, the machines parts are to be disassembled completely and worn out parts are replaced. Some parts of the

machine may be in a condition that they need to be replaced soon. To correct all such difficulties, the machine is stopped from functioning to do all and every repairs to bring back the machine to accurate machining conditions. This called as capital repairs (or) corrective maintenance .

6.18 Planned maintenance programme

The main objective of planned maintenance programme is to increase the production by keeping the machine tools always ready in good condition. It is done by keeping the machine tools to perform all the activities correctly with the required accuracy at desired speed with full safety protection.

The planned maintenance programme is to be prepared and executed as follows.

1. When a new machine tool arrives to the machine shop or the existing machine tools are to be replaced, it is required to install the machine tools properly, level and align them correctly and connect them to the electrical terminals safely.
2. If errors are found in the dimensional accuracy, the errors should be recorded and analysed whether the machine is in bad condition.
3. It is necessary to plan and get ready the materials, spares and tools required for the maintenance in advance so that the maintenance work is carried out in time.
4. The operators and supervisors should know the importance of the cutting speed, feed data of the machine tools.

5. Emergency repair works should be done without any delay in the case of breakdown of any of the machine tools.
6. The machine should be overhauled if the working efficiency of the machine tool goes below a particular level.
7. If the machine tools become very old and not performing to the desired level, it has to be dismantled completely and worn out parts should be replaced to bring it to the normal working condition.
8. The following details should be prepared and made as charts the layout plan of the shop, the size and specification of the machine tools and the parts to be lubricated. The manuals and the list of spare parts of all the machine tools are also to be kept ready.
9. Annual budget for the maintenance work should be prepared atleast six month or once in year in advance.

6.19 Instruments needed for maintenance

- | | |
|---------------------|----------------------------|
| 1. Steel rule | 11. Spanner set |
| 2. Try-square | 12. Hammers |
| 3. Calipers | 13. Screw drivers |
| 4. Micrometer | 14. Wrenches |
| 5. Vernier calipers | 15. Hacksaw frame & blades |
| 6. Gauges | 16. Lubricating devices |
| 7. Vise | 17. Emery sheets |
| 8. Files | 18. Scraper |
| 9. Tap & Die | |
| 10. Screw gauges | |

ACTIVITIES

1. Students to visit the industry and workshops nearby school, to observe how to maintenance of machines and tools.
2. To give exercises to tabulate the tools and instruments for different types of machines.

Questions

Part I.

Choose the correct option **1 Mark**

1. Maintenance done once in a year is known as
 - a. Routine maintenance
 - b. Preventive maintenance
 - c. Breakdown maintenance
 - d. Corrective maintenance
2. Daily maintenance is
 - a. Routine maintenance
 - b. Preventive maintenance
 - c. Breakdown maintenance
 - d. Corrective maintenance
3. Maintenance of belt, bearing and chain is
 - a. Daily maintenance
 - b. Weekly maintenance
 - c. Preventive maintenance
 - d. Corrective maintenance



7. Define backlash.
8. What is lubrication?
9. Name the different types of lubrication.
10. What are the types of maintenance?

Part III.

Answer the following questions in about a page **5 Marks**

11. Explain the “Lubrication”.
12. What are the parts to be lubricated?
13. Explain “Ring Lubrication” with a diagram.
14. Explain wick lubrication with a neat sketch.
15. Explain splash lubrication.
16. Sketch and explain “Grease Lubrication”.
17. Explain Routine Maintenance
18. Explain corrective maintenance.

Part IV.

Answer the following Questions in detail. **10 Marks**

19. Explain any two types of lubrication with diagram.
20. Explain “Preventive maintenance”.
21. Explain “Breakdown maintenance”.
22. Explain “Planned maintenance program”.

Part II.

Answer the following questions in one or two sentences **3 Marks**

4. Define “Maintenance”.
5. What is the objective of maintenance?
6. What do you mean by “wear”?

Welding



Learning Objectives

- Students understand the process of welding and its uses, types of welding used in industries.
- To know about various field of using welding nowadays.



Nirai neera neeravar kaenmai piraimadhi
Pinneera paedhaiyaar natpu. – Kural 782.

The friendship of the wise waxes like the new moon; (but) that
of fools wanes like the full moon.

CONTENTS

- | | |
|--|---|
| 7.1 Introduction | 7.11 Gas welding |
| 7.2 Types of welding | 7.12 Types of welding |
| 7.3 Classification of welding process | 7.13 Filler rods used in gas welding |
| 7.4 Arc. Welding | 7.14 Advantages of Gas welding |
| 7.5 Arc welding equipments | 7.15 Disadvantages of Gas welding |
| 7.6 Difference between D.C. welding generator, and AC welding Transformer. | 7.16 Difference between Arc welding and Gas welding |
| 7.7 Specification of Electrodes. | 7.17 Resistance welding |
| 7.8 Types of Electrodes. | 7.18 Welding Related processes. |
| 7.9 Selection of electrodes. | 7.19 Types of welding joint |
| 7.10 Carbon Arc welding | 7.20 Safety precautions for welding. |



The Inventor of Arc welding is Sir Humbry David, by using two carbon electrodes and he find the flame between the rods.

Gas welding was invented by Nicole Benar Dass, Russian scientist by using oxygen Acetylene gas and found high flame which is used to connect two metals.

7.1 Introduction

Welding can be defined as the process of joining two metal parts by applying heat. In industry, welding process is primarily used for fabricating works.



Welding is useful in making permanent joints. It can be performed by applying or not applying pressure. The contours of the metal parts are molten to make the joint in some methods. In some types of welding processes, filler metal is used. In some other methods, filler metal is not used.

The process of welding finds application in manufacturing automobiles, aeroplanes, rail coaches, machine components, metal structures, boilers and ships. Generally, welding process is applied wherever metal works are performed.

7.2 Types of Welding

There are two types by which welding is performed

1. Plastic welding
2. Fusion welding

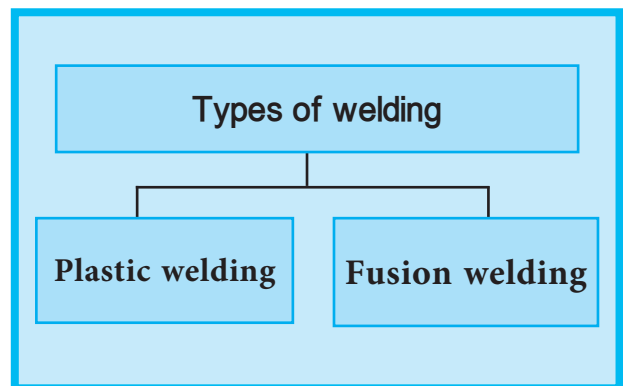

Plastic Welding

In this type, the metal parts are heated to plastic state, In this stage. Pressure is applied to make a perfect joint. It is also known as pressure welding.

Fusion Welding

The metal parts are heated upto the point of melting in this type. The joint is made at this stage and the parts are allowed to cool. On cooling, the molten metal forms a solid joint. No pressure is applied in this method. Hence, it is also known as pressure less welding or Fusion welding Arc welding and gas welding fall in this category.

7.3 Classification of Welding processes

1. Arc welding
 - a. Carbon arc welding
 - b. Metal Arc welding
 - c. Metal inert gas welding
 - d. Tungsten inert gas welding
 - e. Atomic hydrogen welding
 - f. Plasma arc welding
 - g. Submerged welding
 - h. Electro slag welding
2. Gas Welding
 - a. Oxy – acetylene welding
 - b. Air – acetylene welding
 - c. Oxy hydrogen welding
3. Welding related processes
 - a. Oxy – acetylene cutting
 - b. Arc cutting
 - c. Hard facing
 - d. Brazing
 - e. Soldering

7.4 Arc welding

In arc welding, the edges of two metal parts are melted by an electric arc and the joint is made. An electrode made of a suitable metal is utilised for this purpose. The electrode is taken closer to the parts to be joined and electric current is supplied to both the parts and the electrode. An electric arc is made between the electrode and the metal parts. This arc generates high temperature and melts the metal parts. The parts are joined at this molten state. The filler metal in the form of electrode is deposited along the joint. The metal parts are joined without the application of any



pressure. Electrical energy is converted into heat energy in arc welding.



The distance between the metal parts and the electrode should be around 3mm. The heat generated during arc welding ranges from 5000°C to 6000°C. A generator or a transformer supplies the required current to both the electrode and the metal parts. The electrodes are flux coated to prevent the molten metal from reacting with the atmosphere.

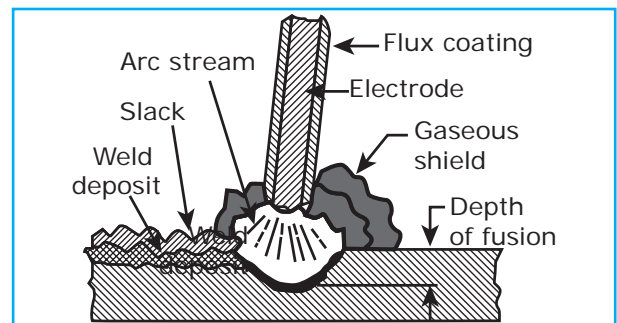

Arc welding

7.5 Arc welding equipments

The following equipments are used for the process of arc welding

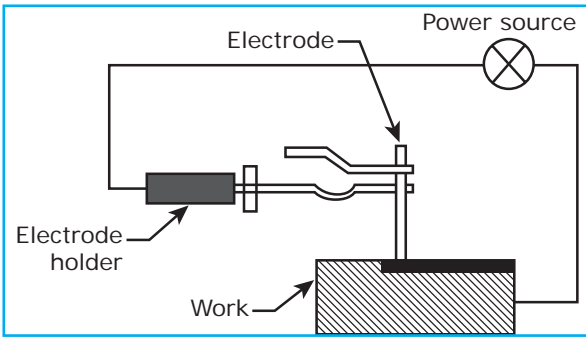

Arc welding equipments

1. D.C welding generator (or) AC transformer
2. Cables
3. Electrode cable
4. Work cable
5. Electrode holder
6. Electrode
7. Gloves
8. Protective shield (or) Goggles
9. Apron for the operator
10. Wire brush
11. Chipping hammer

7.6 Differences between DC generator and AC transformer

DC generator	AC transformer
Low efficiency	High efficiency
High power cost	Low power cost
High machine cost	Low machine cost
Runs on low voltage	Runs on high voltage
Safe equipment	The chances of accidents is high
Uncoated electrodes may be used	Only flux coated electrodes are used
Joints are made with ferrous and non-ferrous metal parts.	Non-ferrous metal parts cannot be joined

Work is connected to the positive terminal (+) and the electrode is connected to the negative terminal (-)	No restriction in the direction of power supply connection
Noisy functioning	No noise during operation
Easy maintenance of equipments	Requires proper maintenance
The cost of the process is low	High process cost
Thin metal parts can easily be welded	Difficult to weld thin parts

7.7 Specification of electrodes

Electrodes - figure

Generally, the size of the electrodes is specified by the length and its diameter. They are available to a maximum of 12 mm diameter and 450mm length. The size of the electrode increases with the current used. In manual welding, the size of the electrode changes according to the thickness of the metal parts. Spring like electrodes are used in automatic welding.



7.8 Types of electrode

The electrodes used in arc welding are two types

1. Consumable electrode
2. Non – consumable electrode

There are three types of consumable electrodes. They are

1. Bare electrodes
2. Lightly coated electrodes
3. Heavily coated electrodes

Non – consumable electrodes are used in the processes of atomic hydrogen welding and TIG welding.

7.9 Selection of electrodes

The material used for manufacturing electrodes depends upon the material to be welded. Given is the list indicating suitable materials for manufacturing electrodes for welding different metals.

S. No	Material to be welded	Electrode material
1	Wrought iron	Low Carbon Steel Rod
2	Mild Steel	Mild Steel, Copper coated Rod
3	Alloy Steel	Nickel Steel Rod
4	Cast Iron	Cast Iron Rod
5	Aluminium	Cast Aluminium Alloy Rod
6	Carbon Steel	Steel wire (0.15% Carbon & 0.025%) Phosphorous & Sulphur
7	Copper	Copper Rod
8	Brass	Brass Rod

7.10 Carbon arc welding

In carbon arc welding, the process of welding is carried out by an electric arc. The arc formed between the electrode and the work piece generates high amount of heat. In D.C electric supply, the carbon electrode is connected to the negative terminal and the positive

terminal is connected to the work piece. During the formation of the electric arc, the temperature of the positive terminal is 4000°C and the negative terminal will be around 3000°C . Carbon, the electrode material will not fuse with the work piece materials. This prevents the joint from becoming weak. A lengthy arc produces carbon – monoxide at the location of welding and prevents the molten metal from reacting with the atmospheric air.

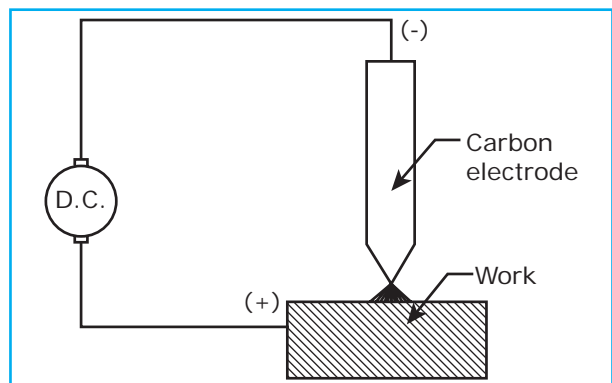

Carbon arc welding

Both ferrous and non-ferrous metals can be welded by this method. Steel sheets, copper and its alloys, brass and aluminium parts are welded using carbon arc welding. This method of welding can also be done automatically. Starting of the electric arc is easy and the temperature is controlled easily. The disadvantage of this method is the presence of blow holes in the joint.

7.11 Gas welding

Gas welding is the process of melting and joining metal parts by means of a gas flame. Generally pressure is not applied during the process of gas welding. Oxygen and acetylene gases are made to pass through the welding torch. These gases are mixed at the required ratio



at the torch and the tip of the welding torch is ignited to produce the flame. Because of the heat generated by the flame, the edges of the metal parts are melted. Filler rod provides the additional metal required for making the joint. The flux coated on the electrodes prevents oxidation and removes impurities. This method is suitable in welding metal parts of thickness varying from 2mm to 50mm. The temperature of the flame is around 3200°C.

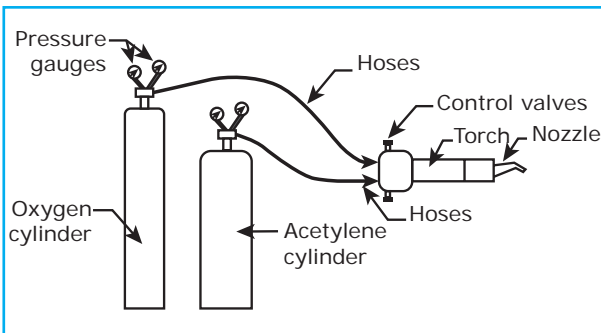

Gas Welding

Gas Welding equipments

The following equipments are necessary for gas welding

1. Gas cylinders
2. Regulators
3. Pressure gauges
4. Rubber hoses
5. Welding torch
6. Safety goggles
7. Gloves
8. Spark lighter
9. Wire brush

Gas cylinders

Oxygen and acetylene gases are stored in separate cylinders and used for gas welding. The colour of oxygen cylinder is black and the acetylene gas is stored in maroon cylinders. Oxygen is stored at a pressure of 125kg/cm². Acetylene gas is stored at a pressure of 16Kg/cm². In the cylinder.



Gas Cylinder

Regulators

Separate regulators are fitted on both the cylinders. A regulator is used to control the working pressure of the gases. The working pressures of oxygen is $1\text{Kg}/\text{cm}^2$ and acetylene is $0.15\text{Kg}/\text{cm}^2$. Working pressure of these gases are altered according to the thickness of the metal parts of the joint.



Regulators

Two pressure gauges are fitted each on the oxygen cylinder and on the acetylene cylinder. One of the pressure gauges indicates the pressure of the cylinder and the other gauge indicates the working pressure of the specific gas.

Hoses

Separate hoses are used to connect the two cylinders with the welding torch through regulators. The colour of the hose from the

oxygen cylinder is black and the one from the acetylene cylinder is red. These hoses carry the gases to the welding torch.



oxygen hose

acetylene hose

Welding torch

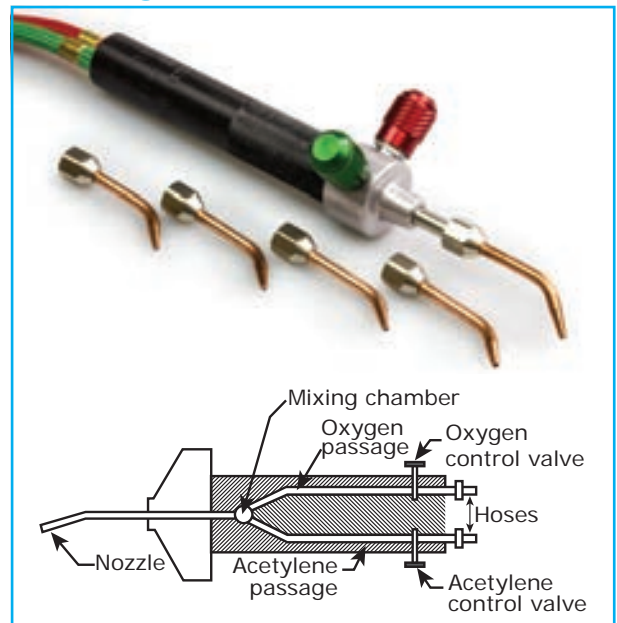

Welding Torch

Oxygen and acetylene reach the welding torch through the passages of hoses from the respective cylinders. These gases

are mixed in the mixing chamber of the welding torch. Flame is produced at the tip of the torch when the gases are ignited. There are two control valves present in the torch to control the quantity of oxygen and acetylene. By this control, the grade of the flame can be altered. The size of the flame is altered to suit the thickness of the metal parts.

Goggles

Oxy acetylene flame emits ultraviolet and infrared rays. These rays are highly harmful to bare eyes. In order to protect the eyes of the welder, goggles should be used by him.



Goggles

Welding gloves

Protective hand gloves are used by the operator to prevent possible damages that may be caused by high temperatures and metal splashes during welding.



Gloves

Spark lighter

Spark lighter is used to ignite the oxy-acetylene gas at the tip of the welding torch.





Spark Lighter

Wire brush

Wire brushes are useful for cleaning the weld before and after the welding process.

7.12 Types of gas flame

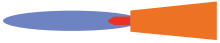
The size of the flame can be altered by varying the ratio of oxygen and acetylene. By doing so, the following three types of flames are obtained.

1. Neutral flame 
2. Carburising flame 
3. Oxidising flame 

Neutral flame

The supply of equal quantities of oxygen and acetylene produces neutral flame. There are two zones in this flame-1. Sharp and bright inner cone and 2. Bluish outer cone. The temperature of the inner cone will be around 3200°C. This neutral flame is generally used as it will not cause any chemical reaction upon the heated metal.

Carburising flame

This flame is also known as reducing flame. The supply of acetylene will be more than oxygen to produce this flame. Carburising flame consists of three zones namely,

1. Sharp inner cone
2. White intermediate cone
3. Bluish outer cone

Carburising flame is useful in welding low carbon steel and alloy steels. It is also used to harden the outer surface of metal parts.

Oxidising flame

Oxidising flame is obtained by supplying more oxygen than acetylene. It consists of two zones namely bright inner cone and outer cone. This flame is useful in welding brass and bronze.

7.13 Filler rods used in gas welding

Filler rods used in gas welding supply the additional metal in making joints. These rods are melted by the gas flame and deposited over the parts of the joint. Generally the filler rods are made of the same metal as that of the parts of the joint.

The diameter of the filler rod depends upon the thickness of the parts to be welded. The strength of the welding joint is increased by adding Nickel or Chromium in filler rods. A thin coat of copper is provided on the filler rods to prevent the molten metal from reacting with atmospheric oxygen. Flux may be applied either in powdered form or liquid form.

7.14 Advantages of gas welding

1. Applied for different classes of work
2. Welding temperature is controlled easily
3. The quantity of filler metal added in the joint can easily be controlled
4. The cost of the welding unit is less
5. The cost of maintenance is less
6. Both welding and cutting can be done

7.15 Disadvantages of gas welding

1. Intended for welding thin work pieces only
2. The process of welding is slow
3. The time taken by the gas flame to heat the metal is more when compared with electric arc.
4. The strength of the joint is less
5. Great care should be taken in handling and storing gas cylinders.

7.16 Differences between arc welding and gas welding

Arc welding	Gas welding
The heat is generated by the electric arc	The required heat is provided by the gas flame.
The working temperature is about 4000°C	The temperature of the gas flame is about 3200°C
The filler rod is used as electrode.	Filler rod is used separately
Care should be taken against the dangers that may be caused because of electricity	The danger of the process is because of the gases at high pressure

The strength of the joint is more	The joint is not as strong as that of arc welding
Brazing and soldering cannot be performed by the electric arc.	The processes of brazing and soldering can be done with the gas flame.
The filler rod metal should be selected as the same metal as that of the parts of the joint.	The filler rod metal can be different from that of the parts of the joint.

7.17 Resistance welding

The process of resistance welding involves

Developing electrical resistance in the parts of the joint to bring them into a plastic state and

Applying pressure on the parts to make the joint.

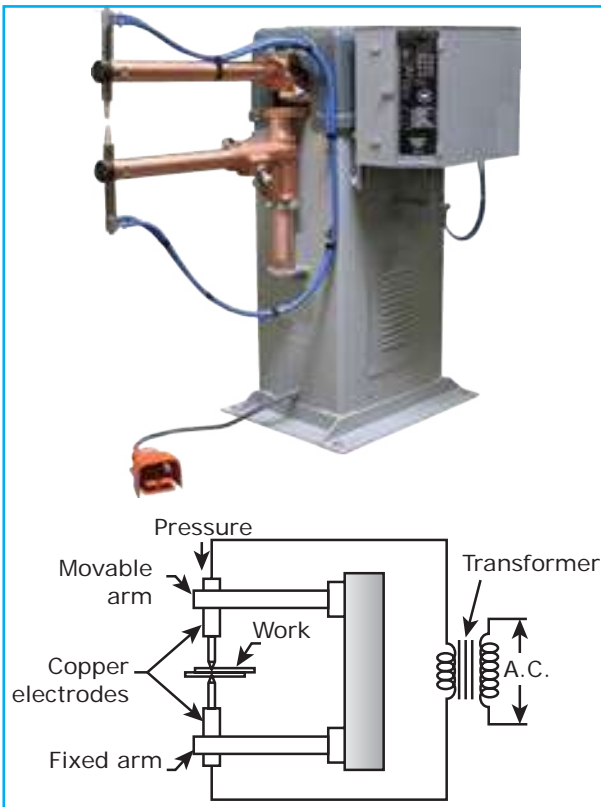

Resistance welding

Two copper electrodes are connected to an electric circuit of low resistance. The parts to be welded are placed between the electrodes. When current is allowed to pass through the electrodes, high electrical resistance is developed at the joint. Because of the resistance, heat is generated at the joint. The metal parts reach plastic state at this high temperature.

At this point, pressure is applied by means of either mechanical or hydraulic or pneumatic power source to make the joint. Current is provided by a suitable A.C. transformer. Resistance welding is useful in welding sheet metal, bars and pipes.

7.18 Welding related processes

Following are some important welding related processes used in industries.



1. Oxy - acetylene cutting
2. Arc cutting
3. Hard facing
4. Soldering
5. Brazing

Oxy-acetylene cutting

Plates made of iron and steel are cut by oxygen, acetylene cutting torch. Oxygen and acetylene are mixed in the cutting torch and a gas flame is generated. The flame heats the sheets to bring them to red hot condition. High pressure oxygen is supplied on the red hot metal through a separate central hole of the cutting torch. Iron and steel sheets are thus cut by the jet of oxygen.

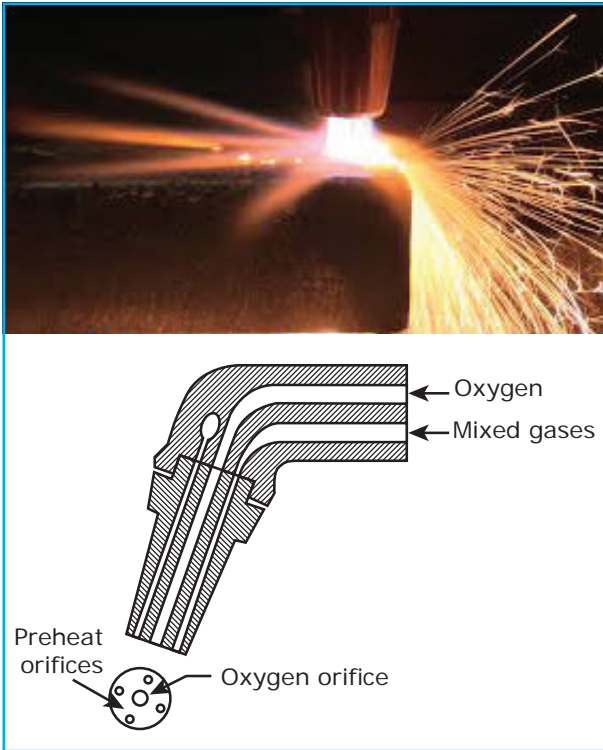

Oxy - Acetylene Cutting

Arc cutting

In this process, the metal parts are heated by means of carbon or metal electrodes. High pressure air is supplied on the molten metal to remove it and cut the metal parts. Oxygen jet is supplied along with the electrode instead of air nowadays. Arc cutting is not suitable for accurate work.

Hard facing

Hard facing is a process of coating a hard material on soft metal parts. Powdered coating metal is filled in the welding gun. The metal powder is melted by the oxy-acetylene gas flame. The supply of inert gas at pressure makes the powdered metal to split into small particles. These particles are sprayed on the surfaces of the soft metal. Coatings of Tungsten carbide, Chromium carbide and Aluminium oxide can be made on the surfaces of different cutting tools and cutters.

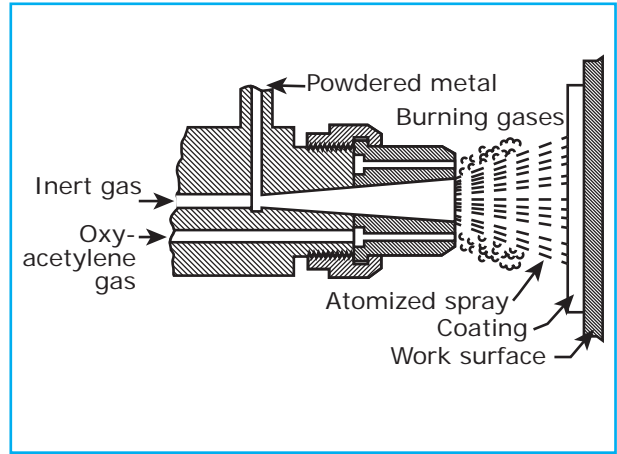

Hard facing

Soldering

Two parts made of similar or dissimilar metals are joined by a solder made of a fusible alloy. Solder is an alloy made of Tin and Lead. The melting temperature of the solder is in the range of 150°C to 350°C. The surfaces of the two metal parts are cleaned and held in correct positions. Flux paste made of zinc chloride is applied on the parts by soldering iron. Application of flux prevents oxidation. The solder is melted by the heat provided by the soldering iron and filled between the metal parts. The solder solidifies and joints the metal parts.

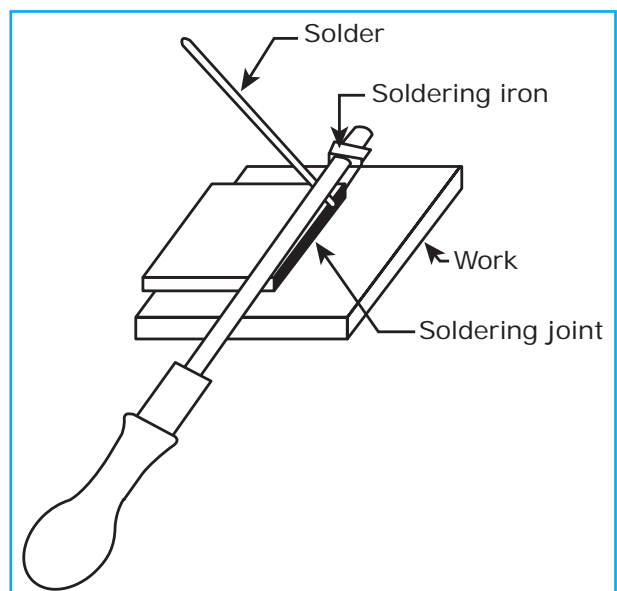

Soldering

Brazing

In brazing, filler metal in molten state is filled between the metal parts of the joint. The filler rod is heated up to 450° C. The parts to be joined are cleaned and the molten filler metal is applied between the parts to make the joint. In this method, the metal parts are not melted.

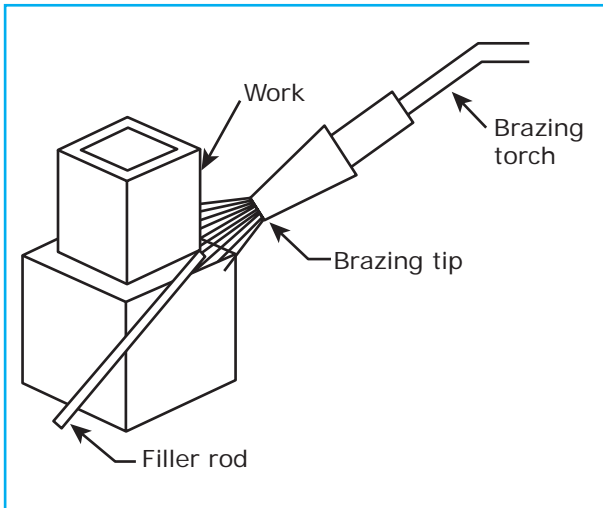

Brazing

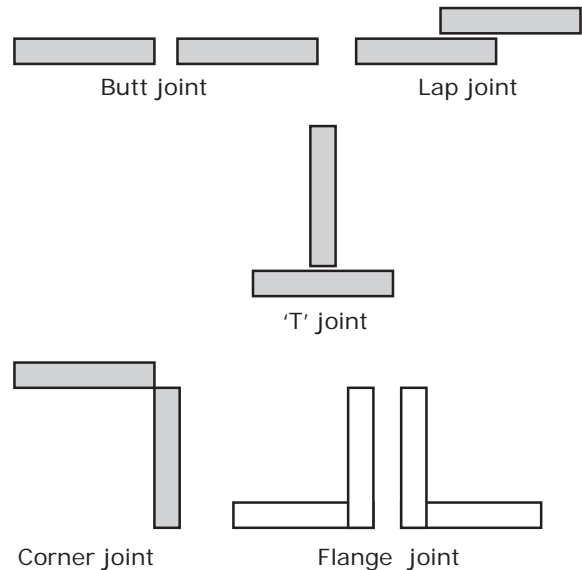

Type of welding Joints

7.19 Types of welding joints

Following are the various types of welded joints

1. Butt joint
2. Lap joint
3. T-joint
4. Corner joint
5. Flange joint

Butt joint

Butt joint is a joint in which the corners or the edges of two metal parts are joined. The process is done by keeping the metal parts on a same plane. The edges of metal parts of thickness upto 5mm may be kept open square. If the thickness of the metal parts exceeds 5mm, edges of the parts need to be prepared in proper shape before welding.

Lap Joint

It is a joint in which the metal plates are placed over lapping before welding. The edge of one part is welded with the surface of the other plate. There are two types of lap joint namely (i) single lap joint and (ii) double lap joint.

T-Joint

This joint is made by keeping the metal plates at perpendicular (90°) to each other. Sheets with thickeners over 3mm only are welded by this type of joints.

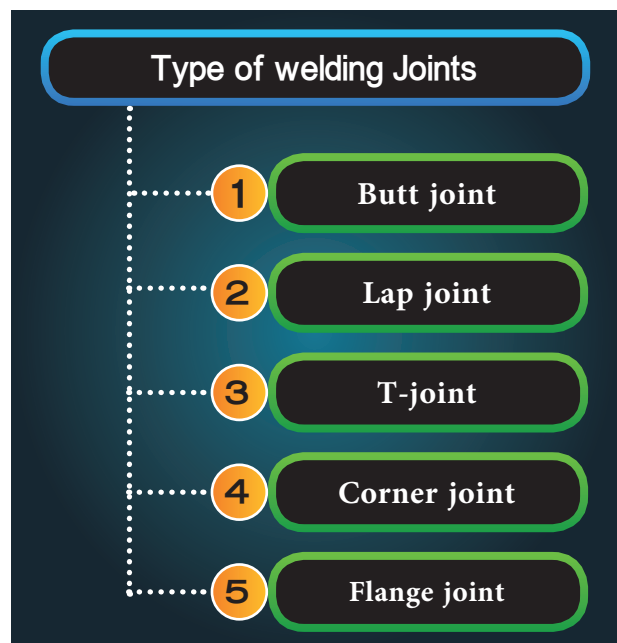

Corner joint

Two metal sheets kept at 90° to each other are welded by this joint. This method is adopted when making boxes and tanks. Corner joints are adopted for thin and thick sheets.

Flange joint

The plates of the joint may be kept parallel or at 90° to each other. The edges of the plates are bent to form the shape of a flange.

7.20 Safety precautions for welding

We make use of electrical devices and inflammable gases like oxygen and acetylene in welding. If proper care is not shown in handling them, there is always a possibility of accidents taking place. So, welding process should be carried out with due safety and caution.

Safety precautions for gas welding

1. Gas cylinders should be kept in ventilated locations.
2. Cylinders should not be kept near hot locations. They should be kept away from electrical terminals.

3. Pressure regulators should be closed after the welding work is completed.
4. Regulators should be handled properly.
5. Old and worn out regulators should be replaced immediately.
6. The operator should wear goggles, gloves, apron and proper footwear.
7. Fire extinguishers and first – aid box should be kept ready always.

Safety precautions for arc welding

1. The welder should always wear goggles. Gloves, apron and proper footwear during welding
2. Welding shop should be located properly so that it does not cause any discomfort to others.
3. The welder should act carefully against electric shocks.
4. A high quality electrode holder should be put into use.
5. Power supply should be provided at required voltage and uniform current
6. Fire extinguishers and First – aid box should always be kept ready in a welding shop.

ACTIVITY

1. Students to visit the welding workshop to study different types of welding joints and give practice any two types of welding joints.

Questions

Part I.

Choose the correct option 1 Mark

1. Carbon Arc welding is related to
 a) Gas welding
 b) Resistance welding

- c) Arc welding
- d) Solid state welding

2. The heat generated during arc welding is
 a) $100^\circ\text{C} - 150^\circ\text{C}$ b) $50^\circ\text{C} - 100^\circ\text{C}$
 c) $5000^\circ\text{C} - 6000^\circ\text{C}$ d) $15^\circ - 200^\circ\text{C}$

3. The pressure of acetylene in the cylinder of gas welding equipments is
 - a) 16kg/cm²
 - b) 125kg/cm²
 - c) 100kg/cm²
 - d) 14 kg/cm²
4. The pressure of oxygen in the cylinder of gas welding equipment is
 - a) 16kg/cm²
 - b) 125kg/cm²
 - c) 100kg/cm²
 - d) 14 kg/cm²
5. Plastic welding is
 - a) Pressure welding
 - b) Resistance welding
 - c) Fusion welding
 - d) Arc welding
6. Fusion welding is
 - a) Pressure welding
 - b) Non-pressure welding
 - c) Resistance welding
 - d) Thermit welding



12. Name the three types of flames generated in gas welding.
13. What are the types of welded joints?

Part III.

Answer the following questions in about a page **5 Marks**

14. Explain any two types of equipments used in gas welding.
15. Explain any one type flame obtained in gas welding with a diagram.
16. What are the advantages of gas welding?
17. Explain the oxy-acetylene cutting with diagram.
18. Explain Hard-facing with diagram.
19. Explain Soldering with diagram.

Part IV.

Answer the following Questions in detail. **10 Marks**

20. Explain arc welding with a diagram.
21. List out the arc welding equipments with a diagram.
22. What are differences between AC arc welding transformer and DC arc welding generator?
23. Explain carbon arc welding with a diagram.
24. Explain gas welding with a neat sketch.
25. List out the differences between arc and gas welding.
26. Sketch and explain resistance welding.
27. What are the safety precautions during the process of gas and arc welding?

Part II.

Answer the following questions in one or two sentences **3 Marks**

7. Mention any three types of arc-welding.
8. State any three types of gas welding.
9. State any three types of welding related process.
10. How is the welding electrodes specified?
11. What are the types of electrodes?

Hydraulic Equipments



Learning Objectives

- Students to understand the hydraulic equipments of pump, cylinder and valves in detail.
- To understand the types of pumps, working method and its applications
- To understand the differences between centrifugal pump and reciprocating pump.
- To understand the hydraulic circuit for shaping machine.



Kaalaththinal seytha nandri siridheninum
Gnaalathin maana perithu. –Kural 102.

A favour conferred in the time need, though it be small(in itself),
is (in value) much larger than the world.

CONTENTS

- | | |
|---|--|
| 8.1 Introduction | 8.10 Difference between centrifugal and a reciprocating pump |
| 8.2 Hydraulic pumps | 8.11 Rotary pump |
| 8.3 Properties of positive displacement pump | 8.12 Hydraulic motor |
| 8.4 Properties of Non-positive displacement pump. | 8.13 Hydraulic cylinder |
| 8.5 Types of centrifugal pump | 8.14 Hydraulic valve |
| 8.6 Types of Reciprocating pump | 8.15 Hydraulic circuit for shaping machine |
| 8.7 Types of Rotary pump | 8.16 Advantages of hydraulic drive over mechanical drive |
| 8.8 Centrifugal pump | |
| 8.9 Reciprocating pump | |



Joseph Bramah (1749 - 1814) was source person for creating hydraulic Technology in 1795. He controlled the machine movements by using the highly pressurized liquid.

8.1 Introduction

The volume of a liquid cannot be changed by applying pressure. This property of liquid forms the base of study of hydraulics. In modern metal working plants, hydraulic pressure is being used to operate practically every type of machine tool.



8.2 Hydraulic pumps

Hydraulic pump is a device, which transforms mechanical energy into hydraulic energy. It serves as the heart of the hydraulic circuit. It provides the force used to move the load in the circuit but the pressure of the circuit is no developed by the pump. The pressure built up in a circuit is because of the quantity of the oil or the setting of pressure relief valve.

Principle of a hydraulic pump

Every hydraulic pump has an inlet and outlet. Partial vacuum is created at the inlet port because of the rotation of the impeller. Hydraulic liquid is forced to flow from the reservoir because of this vacuum through a pipeline and is pumped out through the outlet.

Size of the pump

The size of the pump is specified by the quantity of the oil to be pumped, suction head (the depth from which oil is to be

sucked) and the delivery head (the height up to which oil is to be pumped).

Types of hydraulic pump

Hydraulic pumps are classified according to three different features.

1. According to the displacement of hydraulic liquid.
 - a. Positive displacement pump
 - b. Non-positive displacement pump
2. According to the volume of hydraulic liquid
 - a. Constant delivery pump
 - b. Variable delivery pump
3. According to the nature of movement of the moving part
 - a. Rotary pump
 - b. Reciprocating pump

8.3 Features of positive displacement pump

1. It can pump against high pressure
2. It can handle small amount of oil at high pressure
3. When the pump is working against high pressure, the volume of the outlet will not have any slip. So the outlet should not be closed while pumping as it will cause damage to the pump. A pressure relief valve is connected to the circuit next to this pump.
4. This pump has got self priming (The pump can draw liquid from the reservoir)

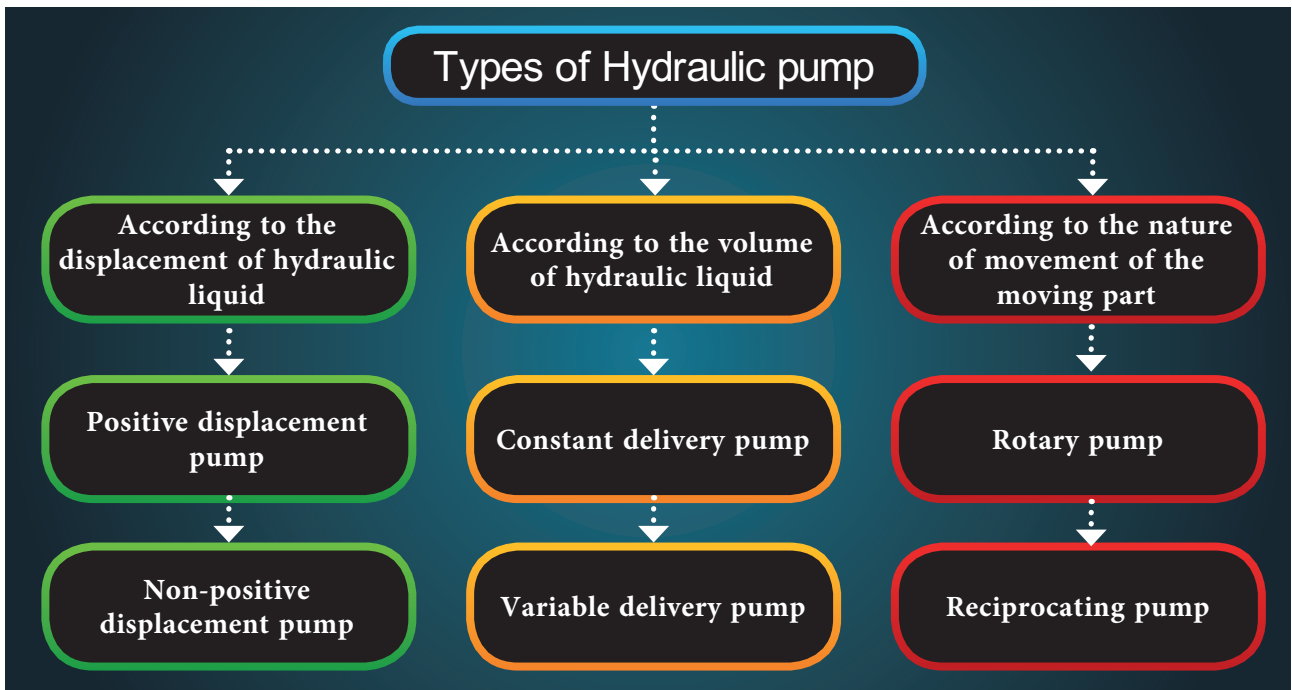

8.4 Features of Non-positive displacement pump

1. It cannot pump against of high pressure
2. It can handle more amount oil at low pressure.
3. A ship is volume will be felt, when the pump is working against at high pressures. Even if the outlet is closed, it will not cause any damage to the pump.
4. Self-priming is not possible.

8.5 Types of centrifugal pump

1. According to head of liquid
 - a. Low lift pump
 - b. Medium lift pump
 - c. High lift pump
2. According to type of the casing
 - a. Volute casing pump of oil
 - b. Vortex casing pump
 - c. Diffuser casing pump

3. According to number of impellers
 - a. Single state pump
 - b. Multi stage pump
4. According to the type of impeller
 - a. Closed impeller pump
 - b. Semi-open impeller pump
 - c. Open impeller pump
5. According to direction of flow
 - a. Radial flow type
 - b. Axial flow type
 - c. Mixed flow type

8.6 Types of reciprocating pump

1. According to the shape of the reciprocating part
 - a. Piston pump
 - b. Plunger pump
2. According to the action of the liquid
 - a. Single acting pump
 - b. Double acting pump
3. According to number of cylinders
 - a. Single cylinder pump
 - b. Multi cylinder pump

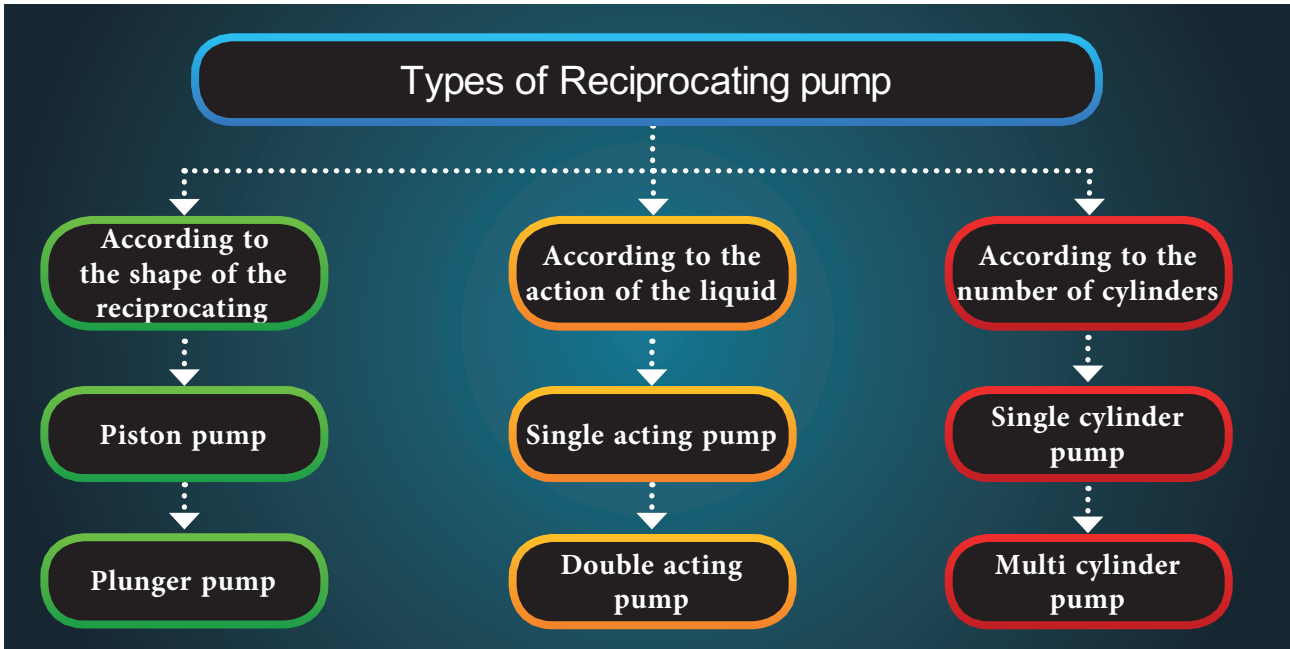

8.7 Types of rotary pump

1. Gear pump
2. Vane pump
3. Lobe pump
4. Screw pump

Special pump

1. Bore-hole pump
2. Jet pump
3. Deep well submersible pump

8.8 Centrifugal pump

Main components of a centrifugal pump:

1. Prime mover
2. Impeller
3. Casing
4. Suction pipe
5. Delivery pipe

Prime mover

The prime mover of a pump may be an electric motor or an oil engine. It provides the rotational power to the shaft of the device.

Impeller

It is the rotating part in the device. Vanes or blades are arranged in series on it. The vanes are fitted on the shaft and rotated by the prime mover.

Casing

Casing is a hollow chamber surrounding the impeller. It is made as an air-tight unit. The sectional area of the casing gradually increases in the direction of the flow of liquid. This construction ensures the decrease in the velocity of the liquid and increase of the pressure.

Suction pipe

The top of the suction pipe is connected to the impeller (inlet). The bottom end is attached with a foot valve and a strainer.

Delivery pipe

The lower end of the delivery pipe is connected to the outlet of the pump. The liquid is pumped out through the other end of the pipe.

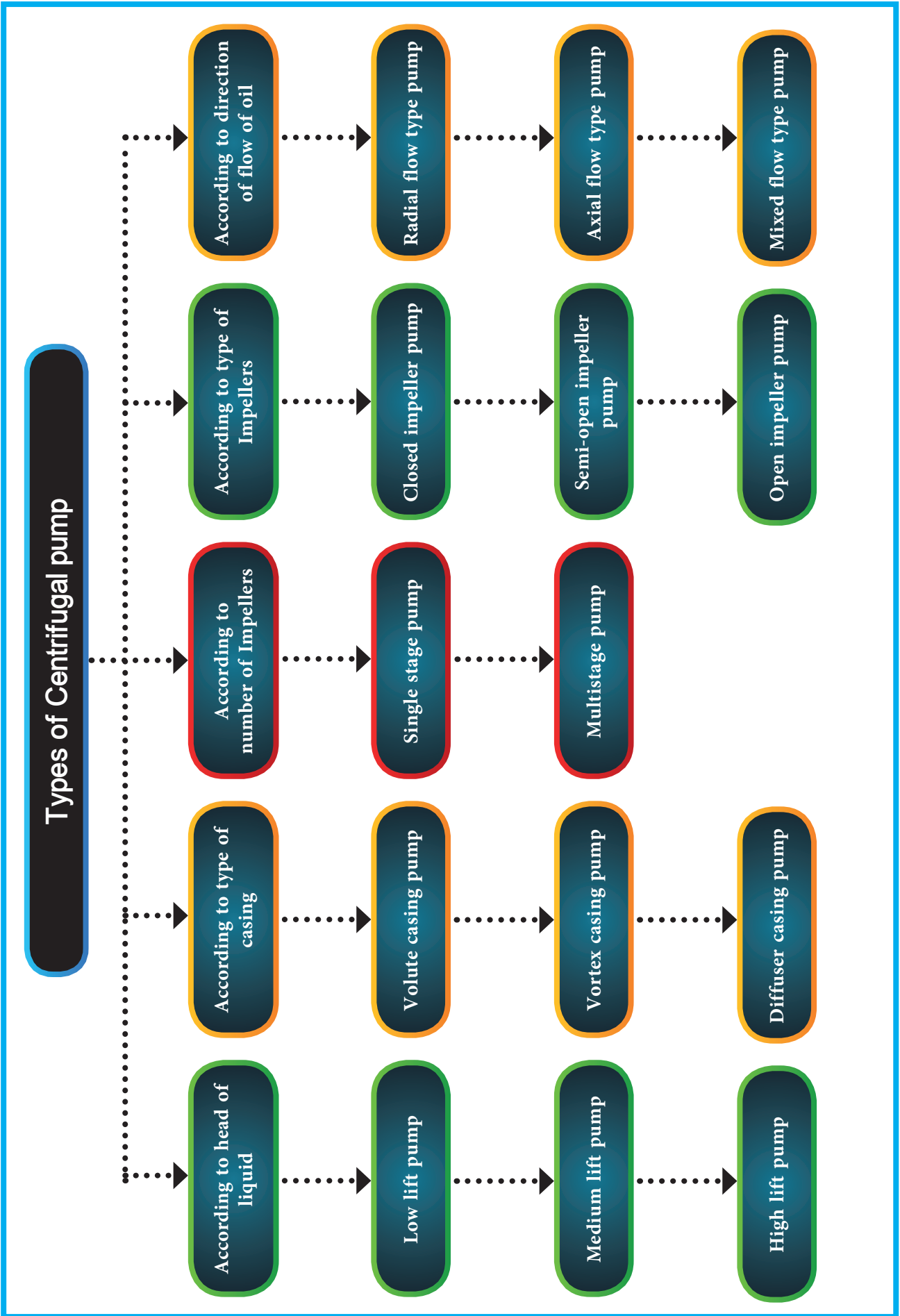

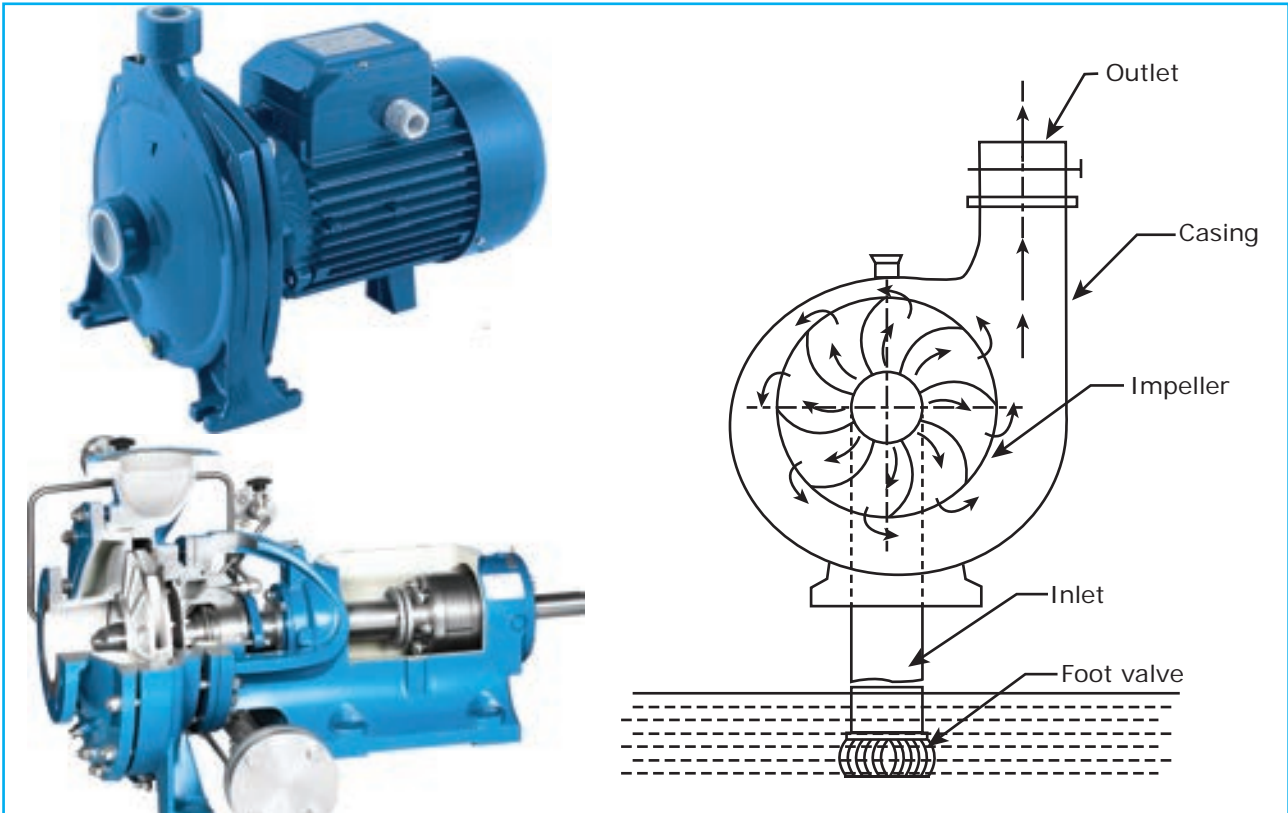

Centrifugal pump

Working principles of centrifugal pump

Before the pump is set on for pumping, priming is done. Priming is done by filling water in the suction pipe and the impeller. While doing so, the air valve is opened. As a result, no air pocket is left in the casing. The presence of any air will certainly decrease the sucking capacity of the impeller.

After the priming is over, the pump is started. The prime mover operates the impeller. The vane on the impeller create centrifugal force inside the casing. Vacuum is created at the centre of the impeller (eye). Water from the reservoir reaches the casing through the inlet. Due to the centrifugal force, water is thrown radically outwards. As the sectional area of the casing gradually increases, velocity energy of the liquid is transformed into pressure energy. The

liquid with increases pressure is pumped to a required height through the outlet. As the impeller goes on rotating, more water is pumped out.

Application of centrifugal pump

- Water pump houses
- Sewage treatment
- Irrigation
- Oil refineries

Advantages

- Durability
- Low cost
- Suitable for pumping coolant

Disadvantages

- Low efficiency
- Limited to be used at low pressure

8.9 Reciprocating pump

Reciprocating pump is one in which the liquid is pumped by the reciprocating action of the moving part known as a piston or a plunger inside a cylinder.

Components of a reciprocating pump

1. Cylinder
2. Piston
3. Connecting rod
4. Crank
5. Suction pipe
6. Suction valve
7. Delivery pipe
8. Delivery valve

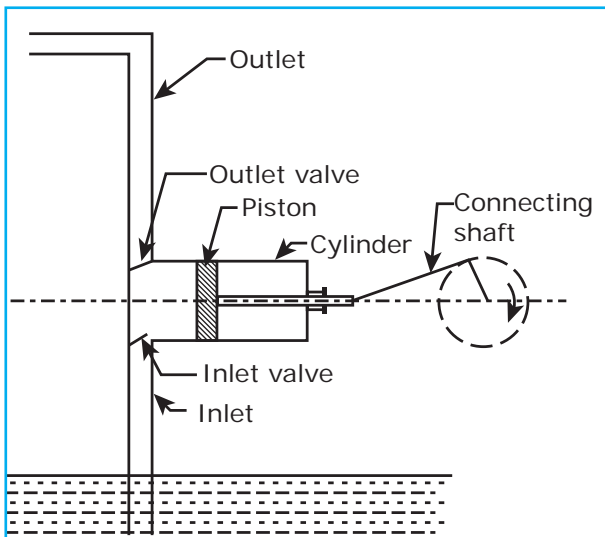

Reciprocating pump

Cylinder

Cylinder is a hollow part inside of which is accurately machined. Piston reciprocates within the cylinder.

Piston

Piston is the reciprocating part of the pump. A connecting rod is connected to it on one side.

Connecting rod

Connecting rod is attached to piston on one end and with a crank on the other end. It converts the rotary motion of the crank into reciprocating motion of the piston.

Working principle of a reciprocating pump

When the crank is made to rotate by means of prime mover, the piston reciprocates within the cylinder to pump out the liquid.

Suction stroke

As shown in fig, when the piston starts moving towards right, a vacuum is created on the left side of the cylinder. The suction valve opens and the liquid is sucked through the suction pipe into the cylinder. The delivery valve remains closed at this stage.

Deliver stroke

Due to the rotation of the crank, piston is moved towards left side. The piston exerts pressure on the liquid inside the cylinder and the delivery valve opens. The liquid is thrown through the delivery pipe with pressure. At this stage, the suction valve remains closed.

On continuous reciprocation of the piston, liquid is sucked and pumped continuously.

Application of reciprocating pump

- Pumping sea water, ship and marine field
- Air pumping devices
- Filling water in small grade boilers
- Oil pumping

8.10 Differences between centrifugal pump and a reciprocating pump

Centrifugal pump	Reciprocating pump
Handles high volumes of liquid	Handles less volumes of liquid
Practically handles all types of liquid, oil, sewage, chemicals, paper pulp, jiggery, and liquids of high viscosity.	Used for pumping pure liquids and liquids with low viscosity.
Rotates at higher speeds	Moves at a slow speed
Not provided with suction valve and delivery valve	Provided with suction valve and delivery valve.
The discharge of liquid is continuous	The discharge is pulsating
Less maintenance cost	High maintenance cost
Less weight	High weight
Occupies less space	Occupies more space
Consists of few simple parts	Consists of complicated parts
The efficiency is low	The efficiency is high

8.11 Rotary pump

The types of rotary pumps are

1. Gear pump
2. Vane pump
3. Lobe pump

Gear pump

In a gear pump, two gears are placed inside a hollow casing in such a way that they rotate in opposite direction. One of these two gears is given rotary motion. The other

gear will also rotate meshing with the first one. The shaft on the driving gear will be extending outside to get rotation from a prime mover. A little gap is left between the gears and the casing.

Working principle of gear pump

The inlet of the pump is immersed in the reservoir. The prime mover actuates the driving gear. This movement makes the other gear also to rotate. As these gears rotate, the liquid is trapped between their teeth and casing. The liquid is pumped out through the outlet of the pump. A gear pump is illustrated in figure.

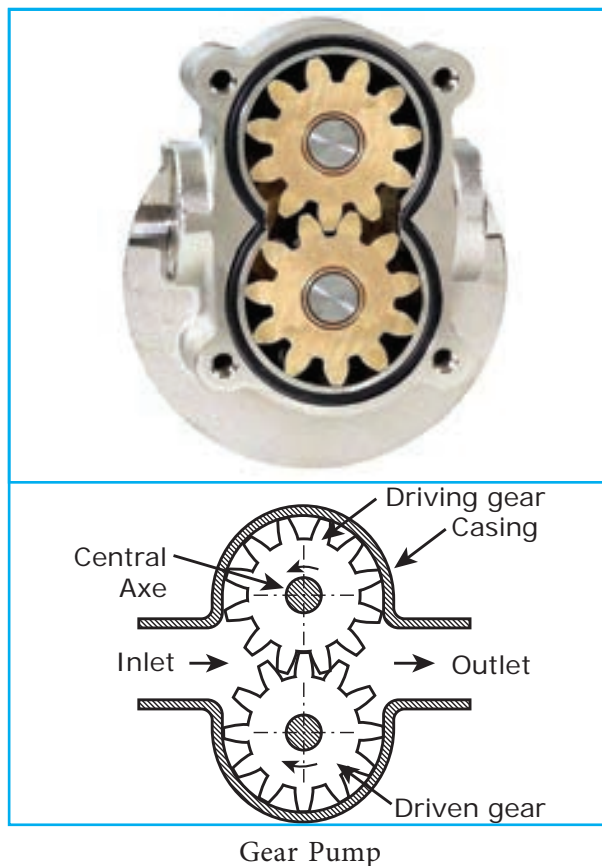

Uses

- Lubricating oil and liquids with high viscosity are pumped by pumps fitted with spur gears. Pumps with helical gears are useful in pumping water and chemicals. Gear pumps can handle pressures up to 140 kg/cm². The output can be 450 liters per minute.

Vane pump

Construction

Vane pumps are equipped with a rotor. Radial slots are present on the rotor. Vanes are attached to these slots and are designed to slide inside them. Rotor is placed inside the casing. The casing and the rotor are placed eccentric. When the rotor is made to rotate, vanes come out of the slots due to centrifugal force. Vanes rotate by touching the inner walls of the casing. In some pumps, vanes are attached to the slots by means of springs to increase the pressure. A vane pump is illustrated in figure.

Working principle of vane pump

The rotor is rotated by a prime mover. The liquid is trapped in between the vanes. The design of the pump is such that the volume of the incoming liquid is increasing and the volume of the outgoing liquid is decreasing. So the liquid from the outlet is pumped with increased pressure. Care is taken that the outlet volume of the liquid does not back to the inlet.

A single layer vane pump can handle pressures from 17.5 to 70 kg/cm² and a two layer pump can handle up to 150 kg/cm² of pressure.

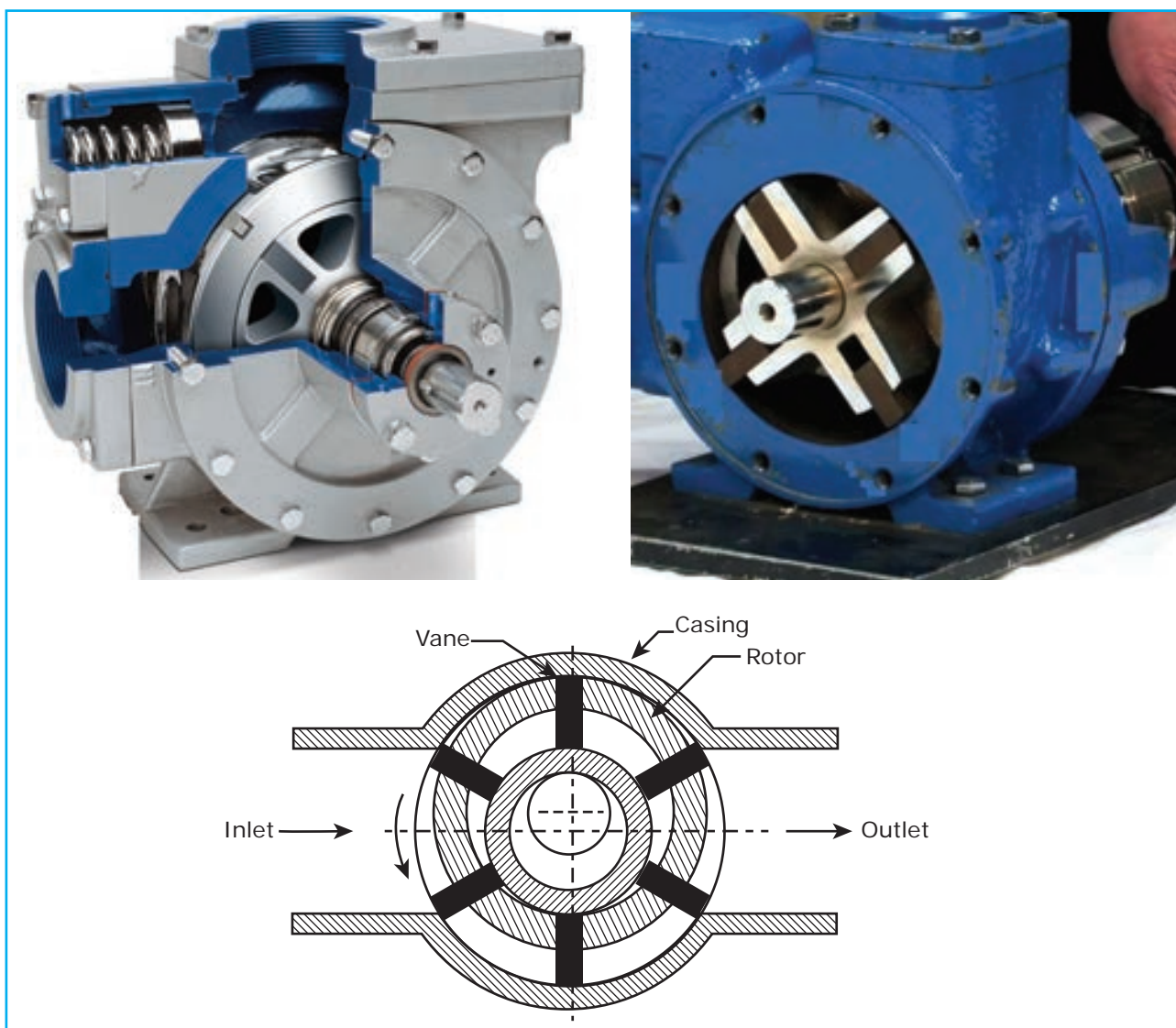

Vane Pump

Lobe pump

In a lobe pump, two lobes are placed inside a casing and casing and are made to rotate to pump out liquids. A lobe pump is illustrated in figure.

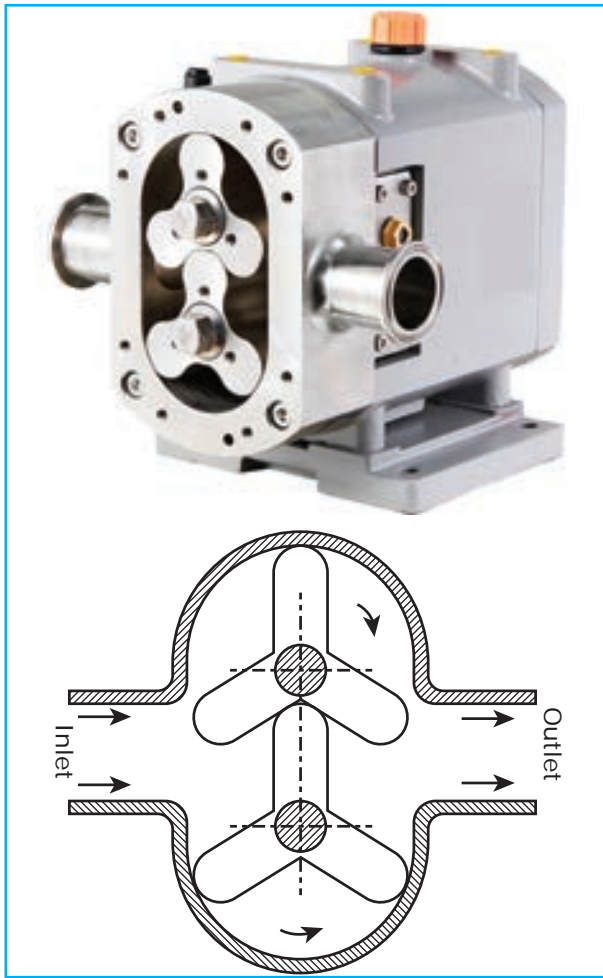

Lobe Pump

The case of the pump is made of cast iron. Both the lobes get rotational power separately to rotate at same speed. Both the shafts will be extending outside to receive power. They are secured properly in the case with proper packing to avoid leakage of oil.

The pump is provided with an inlet and an outlet. The gap between the lobes and the case is minimum and so the oil is pumped through the gaps from the inlet to the outlet.

Screw pump

Screws having helical grooves are used in this pump. When the screw starts rotating, the oil is allowed through the helical grooves. The action of the pump is simple and smooth and pumps out the liquid at high speed. They are used mostly in submarines.

8.12 Hydraulic motor

It is a device used to transform hydraulic energy into mechanical energy. Any hydraulic motor can be used as a hydraulic pump. But a few types of pumps only can be used as hydraulic motor.

The capacity of the hydraulic motor depends upon the quantity of the hydraulic energy that it receives and its mechanical efficiency.

Hydraulic gear

The combination of hydraulic pump and hydraulic motor can be called as hydraulic gear. It is equivalent to a gear box in a mechanical drive.

Types of hydraulic motor

The different types of hydraulic motors are

1. Rotary motor
2. Reciprocating motor
3. Constant speed motor
4. Variable speed motor

As in hydraulic pumps, there are different types of hydraulic motors like gear motor, vane motors, radial reciprocating motor, linear reciprocating motor etc.,

8.13 Hydraulic cylinder

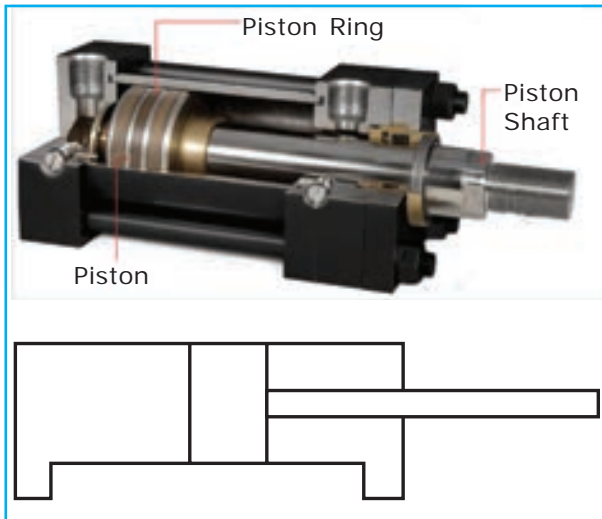

Hydraulic cylinder

A hydraulic cylinder converts hydraulic energy into linear mechanical energy. It is also called as “linear actuator”. The piston placed inside a cylinder can be made to move to a required distance at a required point of time by the liquid.

In order to maintain perfect alignment between piston and cylinder, a leak proof arrangement of piston ring and packing’s (cup shaped packings & ‘V’ shaped packing) are introduced between piston and the cylinder.

8.14 Hydraulic valve

The device which is used for control the quantity, direction and pressure of the flow of liquid passing through hydraulic circuit is called “hydraulic valve”.

The efficiency of a hydraulic circuit depends upon the working condition of hydraulic valves. Hydraulic valves control the hydraulic energy.

Various types of hydraulic valves are used in hydraulic circuits. The most important valves are

1. Direction control valve
2. Pressure relief valve

Direction control valve

The hydraulic valve which is used for change the direction of flow of liquid in a hydraulic circuit is called as “Direction control valve”

Direction control valves are used to allow the hydraulic liquid into various parts of the equipment by changing the direction of flow of the liquid. They are also known as plunger valve, selector valve or main valve.

According to number of inlets (incoming) and outlets (outgoing) available in a hydraulic circuit, the direction control valves are classified as follows.

- a. One way valve or check valve
- b. Two way valve
- c. Three way valve
- d. Four way valve

One way valve

This valve is useful in allowing the flow of liquid in only one direction. It does not allow the reverse flow. A puppet type valve is shown in fig. The valve now is in closed condition by a spring. The liquid enters only one direction.

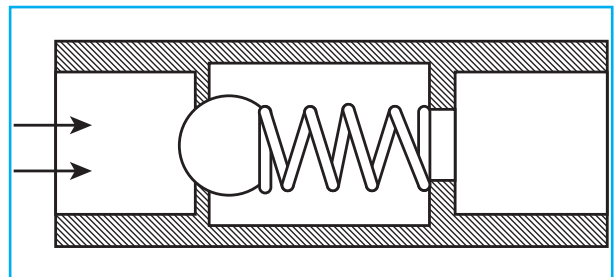

One way valve or check valve

Four way valve

There are four ways in this valve. When the plunger (spool) is pushed to one side, P connects with A and E with B.

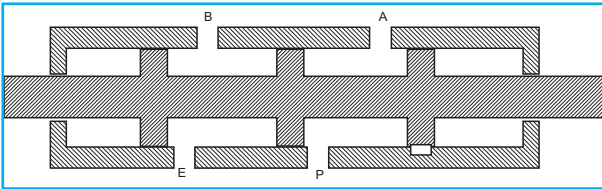

Four way valve

If the plunger reverses, P connects with B and E with A. This four way valve is used for operate and control a double acting hydraulic cylinder.

Pressure Relief valve

The pressure of flow of liquid is limited in a hydraulic circuit. If the pressure exceeds the limit, it affects the hydraulic circuit.

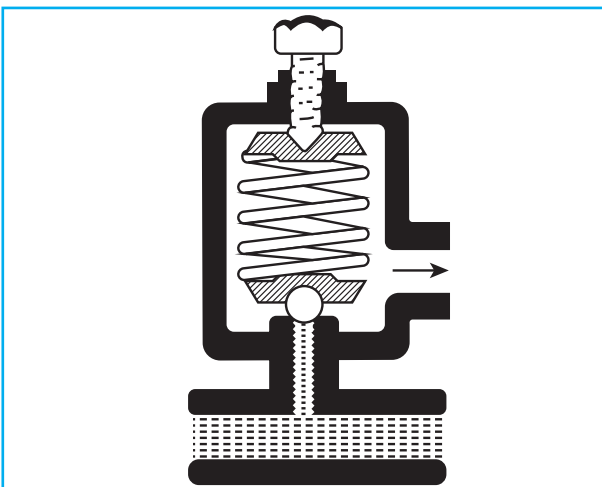

Pressure Relief valve

So pressure relief valve is used for control the pressure of the liquid within the required limit.

8.15 Hydraulic circuit of a shaping machine

The important elements of a hydraulic shaper are

1. Constant discharge hydraulic pump
2. Pressure relief valve
3. Direction control valve
4. Cylinder with piston

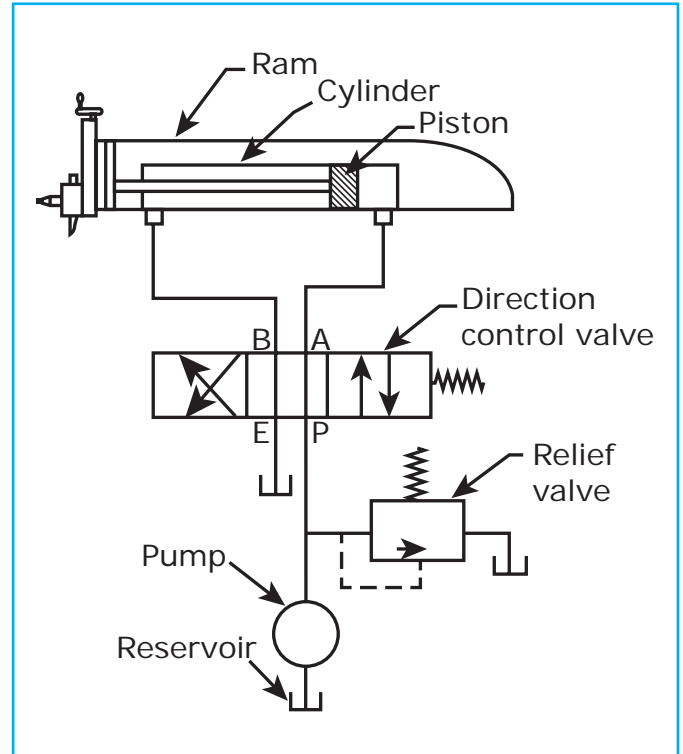

Hydraulic Circuit for Shaping Machine

Working principle

In hydraulic circuit, liquid is pumped by a constant discharge pump into the direction control valve. It has four ways and three stages. If the pressure goes beyond desired limits, the excess pressure is released by the pressure relief valve.

The liquid reaches the right side of the cylinder through the inlet P and outlet A of the valve. Due to the pressure of the liquid, the piston moves towards left.

The tool head moves forward to perform the forward cutting stroke. The liquid on the left side of the piston is sent back to the reservoir through B and E.

Due to the change of position of plunger (spool) inside the direction control valve, the liquid reaches the left side of the cylinder through the inlet P and outlet B. Piston moves towards right. The tool head moves in the opposite direction and this movement is known as the return stroke. The liquid on the

right side of the piston is sent back to the reservoir through A and E.

Quick return of the ram

Due to the change of stroke volume of the cylinder during forward and return stroke the piston returns at a faster rate. The stroke volume of the cylinder during return stroke is comparatively smaller than during forward stroke due to the presence of the piston rod. So the pressure increases automatically to push the piston and the tool head at a faster speed during return stroke.

8.16 Advantages of Hydraulic Drive over Mechanical Drive

1. Producing of heat is removed, when mechanical force is applied
2. It has high efficiency. No sound is produced
3. Always pressure is even
4. Hydraulic equipments are stable
5. No need of locking the hydraulic equipments
6. Withstand the overload accurately
7. Piston is functioned without decreasing of pressure inside, even if the flow of liquid is stopped in hydraulic equipment
8. Hydraulic energy can be transformed easily to desired place
9. It is easy to operate the control equipments of hydraulic drive
10. There is no need of belt, chain, clutch, brake, cam, lever in hydraulic drive
11. It is easy to change the speed of rotational, horizontal, continuous, or constant force of work in hydraulic drive
12. It is reliable and acts rapidly
13. It is very simple to form
14. Low space is enough
15. It can be done the work at desired place even if the hydraulic equipment is in long distance
16. It is possible to change the direction of rotational or linear movement of hydraulic equipment in working condition
17. Rotational or linear speed may be changed or not, according to our head
18. It is possible to get minimum force with minimum energy
19. Easy to design machines, when using of hydraulic equipment
20. Erection and maintenance is easy
21. If using of electrical equipments caused danger, we may use hydraulic equipments instead of electrical equipments.

Disadvantages

- Leakage of oil causes dust and dirt
- Hydraulic pipes may be damaged due to dust
- If the pressure of flow oil exceeds the limit, hydraulic pipe may be burst.
- Due to leakage of oil, there may be causing of fire accident

ACTIVITIES

1. To arrange the students to know about the working principle of hydraulic equipments by visiting polytechnic or Engineering college.

Questions

Part I.

Choose the correct option 1 Mark

1. A device which transforms mechanical energy into hydraulic energy is
 - a. Hydraulic pump
 - b. Hydraulic Cylinder
 - c. Hydraulic motor
 - d. Hydraulic valve
2. Impeller is a part found in a
 - a. Reciprocating pump
 - b. Gear pump
 - c. Centrifugal pump
 - d. Vane pump
3. The pump which is used in ship and marine field
 - a. Centrifugal pump
 - b. Reciprocating pump
 - c. Rotary pump
 - d. Special pump
4. The device which is used for control the quantity, direction and pressure of the flow of liquid passing through hydraulic circuit is
 - a. Hydraulic pump
 - b. Hydraulic motor
 - c. Hydraulic cylinder
 - d. Hydraulic valve



Part II.

Answer the following questions in one or two sentences 3 Marks

5. Define “Hydraulics”
6. What are the uses of “centrifugal pump”?
7. What is “priming”?
8. What are the uses of “hydraulic cylinder”?

Part III.

Answer the following questions in about a page 5 Marks

9. What are the five major types of centrifugal pump?
10. What are the types of reciprocating pump?

Part IV.

Answer the following Questions in detail. 10 Marks

11. List out the difference between a centrifugal pump and a reciprocating pump?
12. Draw the circuit of a hydraulic shaping machine and label its parts and explain its working principle.

CNC Machines



Learning Objectives

- Students to know how the machines are controlled by numerical control.
- To know about the computer numerical control machines, its elements and functions of elements.
- To know about the classification of CNC machines in detail.
- To know about the programme of CNC machine.



Nandrikku viththaagum nalozhukkam theyozhukkam
Endrum idumbai tharum. –kural 138

Property of conduct is the seed of virtue; impropriety will ever
cause sorrow.

CONTENTS

- 9.1 Introduction
- 9.2 Numerical control
- 9.3 Computer Numerical control
- 9.4 Elements of CNC machines.
- 9.5 Software
- 9.6 Input Media
- 9.7 Machine control unit
 - a. Inbuilt MCU
 - b. Swivel MCU
 - c. stand alone MCU
- 9.8 Driving devices
- 9.9 Machine tool.
- 9.10 Classification of CNC machine tools.
- 9.11 Advantages of CNC machines over conventional machine tools.
- 9.12 Programming for CNC machines.
- 9.13 Advancements in NC machines.



Numerical control machine was invented by an American John T. Parsons in 1940. He worked in Massachusetts institute of technology.

9.1 Introduction

Production is a process of converting raw material into finished products. The process of productions is achieved by the collective efforts of man and machine using materials and tools. It requires information and energy to accomplish production by machining. Over the period of time, several techniques and methods are used in the process. The evolution of new methods of production saw the increasing involvement of machines in providing the information and energy required for production and the role played by the humans declined.

Prepared programs consisting of information and instructions took the role of controlling the machines instead of manual control. This has led to a manufacturing system of higher production at lower cost with more accuracy.



CNC Machine

9.2 Numerical control

In NC system, intervention of human beings in the machining process is substituted by some operating instructions in a coded

form. This coding, otherwise known as part program, is stored in cards or tapes. Getting the required instructions from these input media, the machine carries out different tasks in a proper sequence.

Numerical control can be defined as a system in which actions of a machine tool are controlled by recorded informations in the form of numerical data.

9.3 Computer Numerical Control

When the activities of a numerical control machine is administered by a computer, it is known as computer numerical control machine tool. The functions of the machine tool are controlled by the instructions stored as programs in the computer.

9.4 Elements of CNC machines

As explained earlier, the NC system requires the preparation of part program based on the product drawing, preparation of input media (punched cards & punched tapes), the data entry into the control unit, consequent processing and actuation of the machine tool to produce the desired part.

To perform all the above operations the NC machine have the following elements

1. Software
2. Machine control unit
3. Driving devices
4. Machine tool

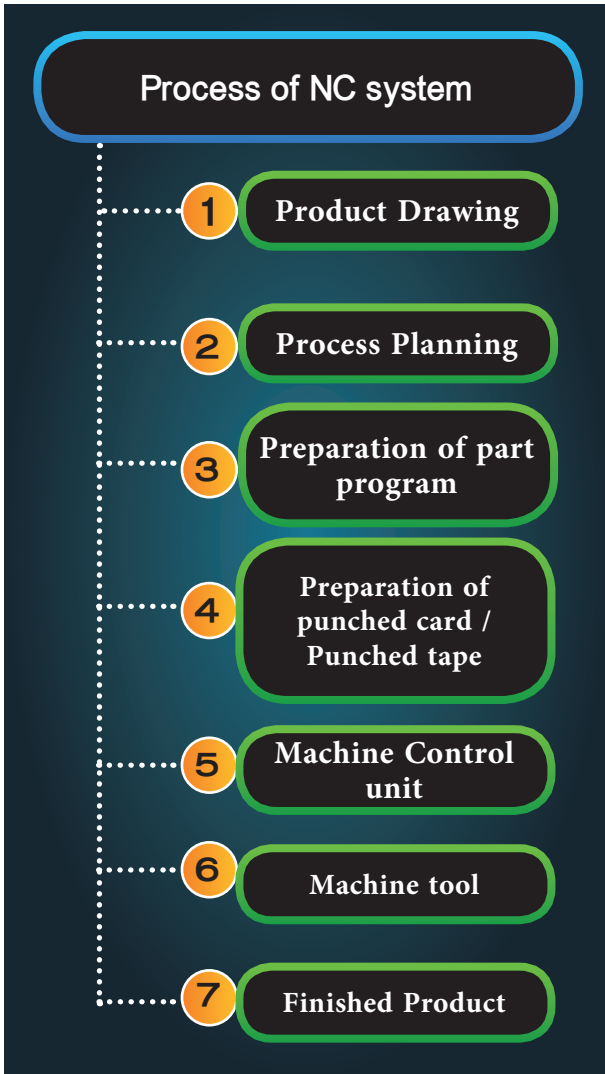

1. Punched cards
2. Punched tapes
3. Magnetic tapes
4. Floppy disks

Punched cards and punched tapes are useful in storing data in the form a series of punched holes. Punched tapes may be made of paper, plastic or aluminium foils. Magnetic tapes are made of plastic material and coated with Gamma ferric oxide layer. Magnetic tapes may be used for storing more informations and it may erased and reused.

9.7 Machine Control Unit (MCU)

Machine Control Unit consists of electronic circuits (hardware) that are useful in reading and interpreting the instructions (NC



program) fed by means of input media and convert them into mechanical actions of the machine tool.

There are three types of MCU. They are

- A. Inbuilt type
- B. Swivel type
- C. Stand alone type

A. Inbuilt MCU

When the control unit of the NC machine is mounted in the construction of the machine itself, it is known as Inbuilt MCU. Inbuilt MCU is shown in figure.

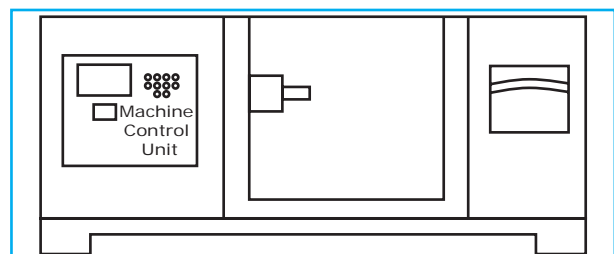

Inbuilt MCU

9.5 Software

Software of a NC system can be referred to items comprising of instructions, (programs) computer languages used for write these programs and a variety of input media.

In order to provide informations into the control unit or a computer, binary format is used. In this system, only two digits 0 and 1 are used.

9.6 Input Media

Different types of input media are used to store informations and to provide input to various control units of the NC machine. They are

B. swivel MCU

The MCU is a separate unit and is connected to the machine by swinging arrangements. The MCU as a whole can be swing around the machine depending upon the position of the operator. Swivel MCU is shown in figure.

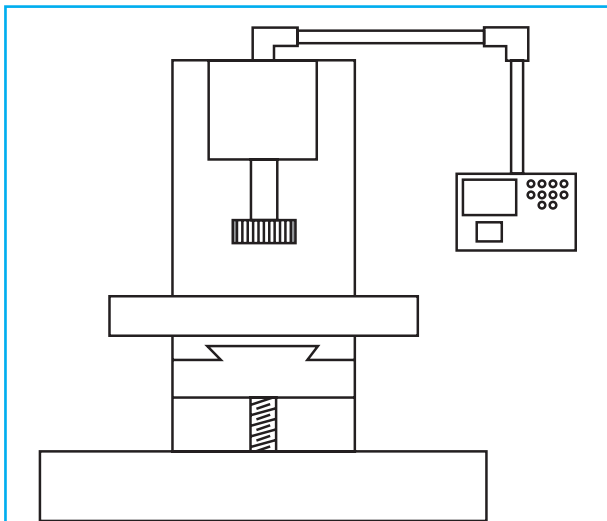

Swivel MCU

C. Stand alone MCU

Stand alone MCU is designed as a separate unit and placed at a distance from the machine. Stand alone MCU is shown in figure.

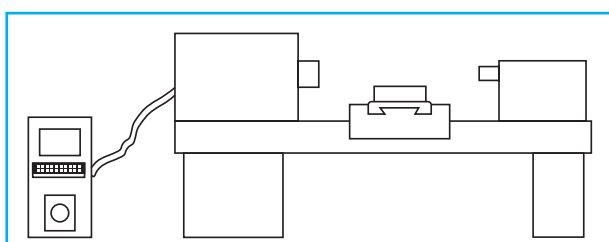

Stand Alone MCU

Elements of a machine control unit

A machine control unit consists of following elements

1. Input reading unit
2. Memory unit
3. Processing unit
4. Output unit
5. Feedback unit

Input Reading Unit

It is a electromagnetic device useful in reading the NC programs in the form of instructions.

The main functions of an input reading unit are

1. To accept the input media
2. To collect the input media instructions.
3. To send them into processing unit.
4. To keep the input media safety for reuse.

Memory Unit

The information received from input reading unit will be saved in memory unit. It will be send to processing unit, when it is required.

Processing Unit

The informations received from the memory unit are processed here and are given to various parts of the CNC machine. The processing unit serves as a link between the memory unit and output unit.

Output Unit

The wires coming out of the processing unit are called output unit. This output unit emit electric pulses of low voltage. In order to drive various slides of the machines, the pulses are amplified by means of electronic or electro-magnetic amplifiers.

Feedback Unit

Feedback unit consists of some electrical or electronic hardware. This is used for converting physical quantities like displacement and velocity into electrical pulses.

Process of a NC Machine Tool



9.8 Driving devices

Driving devices consist of different types of motors and gear trains. They convert the instructions from MCU, into accurate mechanical displacements of the machine tool slides.

Servomotor, stepper motor, synchros and resolver are different types of motors used as drives in NC machines.

9.9 Machine tool

Machine tool is the machine which converts the raw materials into finished components. It is designed to perform various machining operations.

It consists of a machine table, spindles, cutting tools, work holding devices such as jigs and fixtures, coolant systems, swarf removal systems and other auxiliary equipments.

9.10 Classification of CNC Machine tools:

CNC machine tools are classified as follows

1. According to the type of power to the drives
 - a. Electrical
 - b. Hydraulic
 - c. Pneumatic
2. According to motion control system of slides
 - a. Point-to-point System
 - b. Continuous path system
3. According to the feedback system
 - a. Open loop system
 - b. Closed loop system



4. According to number of axis

a. 2 – axis	b. 3 – axis
c. 4 – axis	d. 5 – axis

Motion control unit

The cutting tool and the work are located at certain positions in NC machine. During the machining, they are moved from their positions with relation to each other. This system is known as “motion control system”

Point to Point motion control system

Machining is performed only after the cutting tool and the works are located (positioned) at defined positions and there will not be any change in their positions during machining. This system is also called positioning system for this reason.

The relocation is achieved by their movement in two main axes (x axis and y axis). This is the reason for this system to be called as point-to-point system. This system is used in drilling machines, jig boring machines and spot welding machines.

Continuous path motion control system

In this system, both the cutting tool and the work change their positions depends all axes during machining. This system is also called as ‘contouring system’ and is mainly used in milling machine.

Feed back control system

The actual output movement of NC machines is compared with the desired value as given in the input media. This type of control system is called as “feedback control system”.

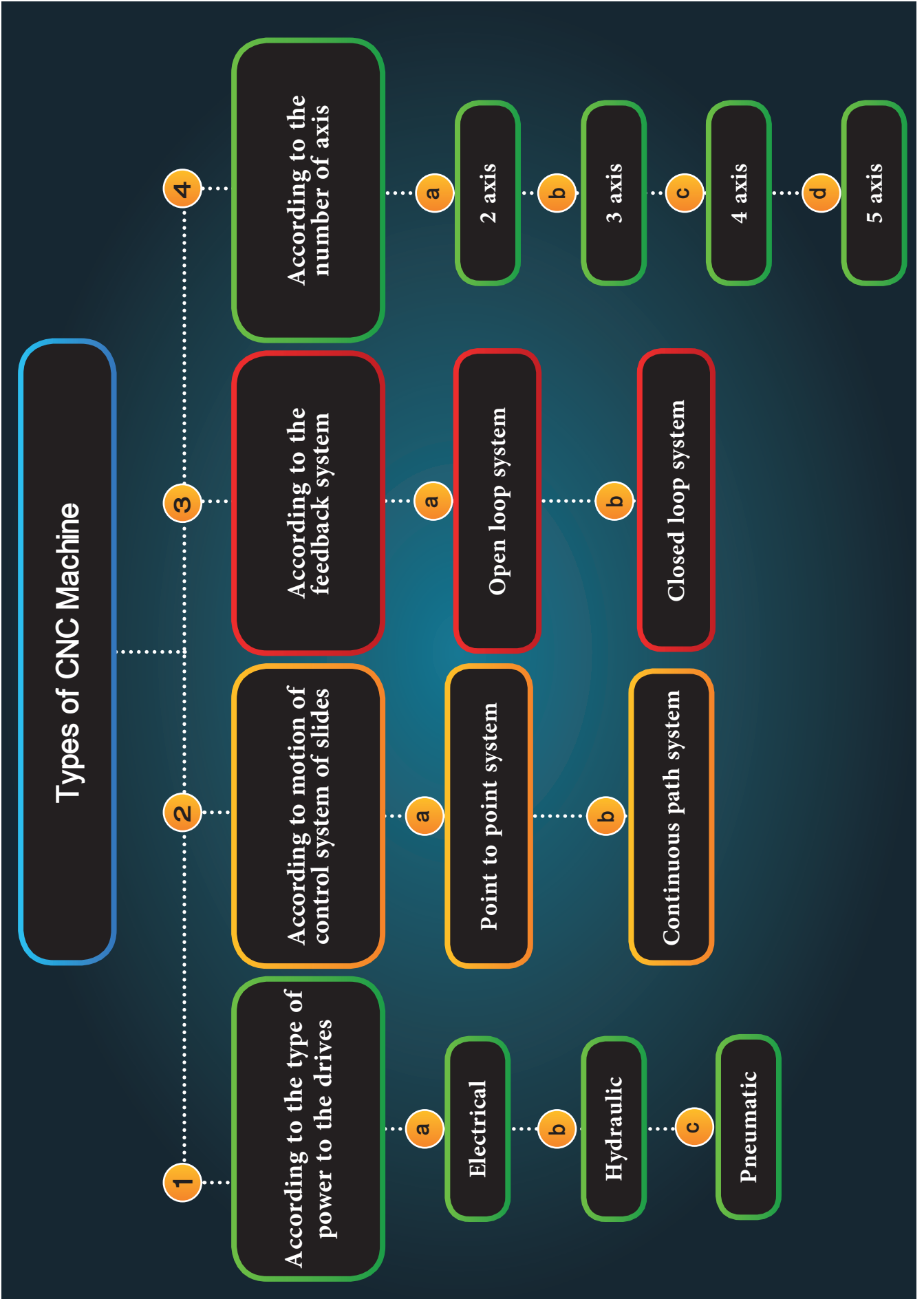

Open loop system

When a NC system does not have any feedback arrangement, it is known as 'open look system'. In this system actual output movement of spindle and table is not compared with the desired movement given by input media.

Closed loop system

The movements of spindle and sliders are measured and compared with the values given by input media. If the output values are not matched with input values, the difference is corrected in machine control unit of NC machine. This system is used where the higher accuracy is required.

9.11 Advantages of CNC machines over conventional machine tools

1. The process of production, planning becomes easy.
2. The production of a single CNC machine is equivalent to production of many conventional machine tools. So the time is lesser.
3. As a single CNC machine is doing many machine functions, it is not necessary to buy many machines. It ensures reduction of floor space.
4. The time required for making input media is very less, when compared with making jigs and fixtures.
5. Smaller quantities of production is possible so keeping low raw material is enough
6. The design change of the component can be done easily and quickly
7. As the CNC machines require very little attention of the operator, the machine utilization is better
8. Jigs and fixtures are not used in CNC machines. It reduces the tooling costs.
9. In a single set up of tool and work piece, many operations are done. So the time is saved
10. Due to higher accuracy, it leads to better assembly and reduces fitting costs. The quality of the product also becomes better.
11. Operators errors are less, so wastage is also less
12. As a single operator can supervise several machines at a time, the labour cost is reduced.

9.12 Programming for CNC Machines

Based on the component drawing, a lot of information are need to be fed into the control unit for processing and machining. The informations include dimensions, shape, cutting speed, feed, depth of cut, sequence of operations, tool and work material. The said information should be fed into the machine control unit in an acceptable form. Preparation of the instructions in the above form is known as 'programming'.

Part Program

A series of instructions describing the part to be produced in an acceptable form to the control unit or computer is known as part program. Generally part programming is done be the following methods.

1. Manual assisted part programming
2. Computer assisted part programming

APT (Automatically programmed tools), ADAPT, EXAPT, SPLIT, PROMPT are some of the high level languages for writing NC programs.

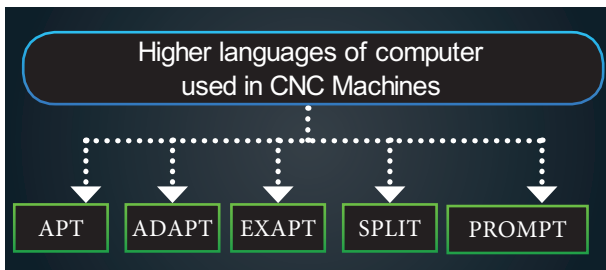

9.13 Advancements in NC machines

After the modern micro-processor based computers took control of the NC system, the technology in this field has grown tremendously. Following are two major advancements of NC system.

1. Direct Numerical control(DNC)
2. Adaptive control(AC)

Direct Numerical control (DNC)

A manufacturing system in which several NC machines are connected to and controlled by a remotely located main frame computer is known as 'Direct Numerical Control' (DNC). The basic constituents are

- a. Main frame computer
- b. Bulk memory
- c. Network system
- d. NC machine tools

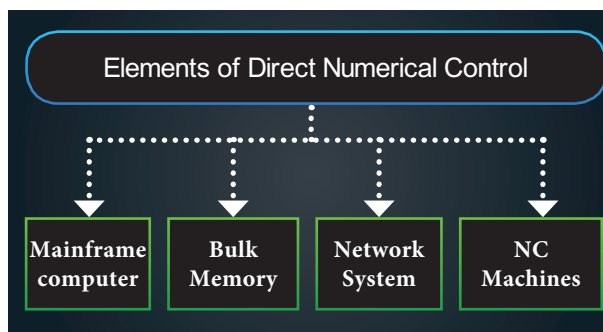

DNC system eliminates the need of separate machine control units, input media, this system governs the scheduling of work of all the NC machine tools. The required network system may be a LAN (Local Area Network) or WAN (Wide Area Network)

Adaptive control

During machining, cutting speed, feed and depth of cut are measured and compared with desired values.

If it is not so, it will adapted (modified), then it is called as "Adaptive control".

ACTIVITIES

1. Students to visit the polytechnic, Engineering colleges for showing the CNC machines and its functioning.

Questions

Part I.

Choose the correct option 1 Mark

1. Production is achieved by
 - a) man and machine
 - b) materials and tools
 - c) men, machine, materials and tools
 - d)men and tools
2. In NC system the program instructions are given as,
 - a) Information
 - b)numerical data
 - c) symbols
 - d)thread symbols

3. IC refers to
- a) Information control
 - b) Instruction control
 - c) Internal control
 - d) Integrated circuits



4. When a NC system does not have any feed back arrangement, it is known as
- a) Positioning system
 - b) contouring system
 - c) closed loop system
 - d) open loop system

Part II.

Answer the following questions in one or two sentences 3 Marks

- 5. Define “Numerical control”.
- 6. What are the types of Machine control unit?

- 7. Mention any three types of elements in Machine control unit.
- 8. What are the functions of input reading unit?

Part III.

Answer the following questions in about a page 5 Marks

- 9. Draw a flow – chart of NC system.
- 10. Explain “Input Media”
- 11. Explain with neat sketch any one types of Machine control unit.

Part IV.

Answer the following Questions in detail. 10 Marks

- 12. Draw a flow-chart of “Machine Tool”
- 13. What are different types of CNC machines? Explain “point to point motion control system”.

Automation and Robotics



Learning Objectives

- Students to know about, how the automatic machine is working without man, working principle and their automatic technology.
- Students to know about how the Robotic machine is working as man are man's activities.



Ennenba enai ezhuththenba ivvirandum
Kannenba vaazhum uyirkku. –Kural 392

Letters and members are the two eyes of human being.

CONTENTS

- | | |
|--|---------------------------------------|
| 10.1 Introduction of Automation | 10.10 Advantages |
| 10.2 Types of Automation | 10.11 Three main components of Robots |
| 10.3 Need for industrial Automation | 10.12 Asimov Laws of Robotics |
| 10.4 The advantages of Automation | 10.13 Need of Robotics |
| 10.5 Applications of Automation | 10.14 Types of Robots |
| 10.6 Elements of Automation | 10.15 Applications of Robotics |
| 10.7 Introduction of Robotics | 10.16 Parts of Robots |
| 10.8 Definition of Robotics | 10.17 Materials used for Robots |
| 10.9 Objectives of industrial Robotics | |

10.1 Introduction of Automation

Automation is the technology by which a process or procedure is performed without human assistance.



Automation covers applications ranging from a household thermostat controlling a heater, to a large industrial control system.

Automation has been achieved by various means including mechanical, hydraulic, pneumatic, electrical, electronic devices and computers, usually in combination. Complicated systems, such as modern factories, airplanes and ships typically use all these combined techniques.

The word “Automation” is derived from ancient Greek words of Auto (means “Self”) Matos (means “moving”). Thus, a mechanism move by itself or self dictated is called automation.

10.2 Types of Automation

1. Based on control

a. Partial Automation

It means replacement of human activities or involvement by automatic means only partially.

b. Fully automation

The human involvement is totally eliminated and the process is entirely carried out and controlled through automatic means along with a proper feedback system.

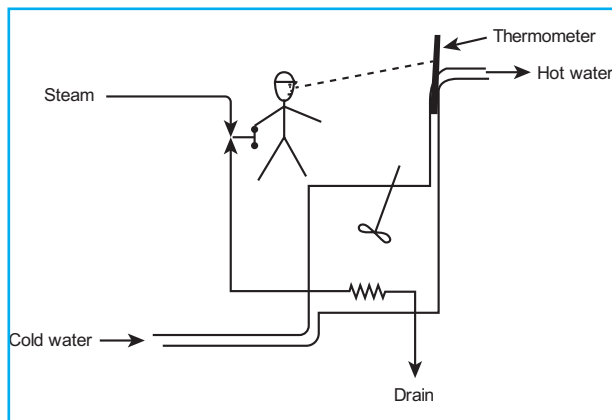

Partial Automation

2. Based on Application

a. Building Automation System (BAS)

It is the automatic centralized control of building’s heating ventilation, air conditioning and lighting and other systems through a building automation system (BAS). The classifications are

- i. Home Automation
- ii. Office Automation

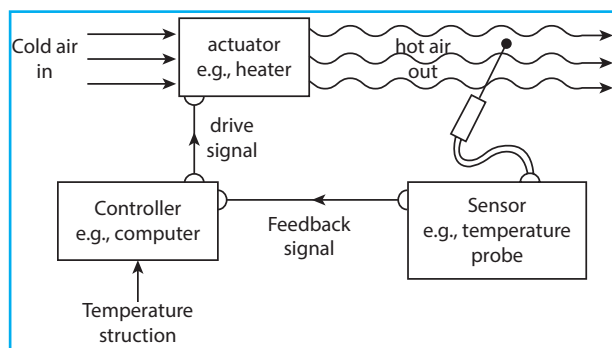

Whole Automation

b. Industrial Automation

It is use of computers and robots to control industrial processes like manufacturing without significant human assistance. The classifications are



Building Automation System (BAS)



Home Automation



Industrial Automation System

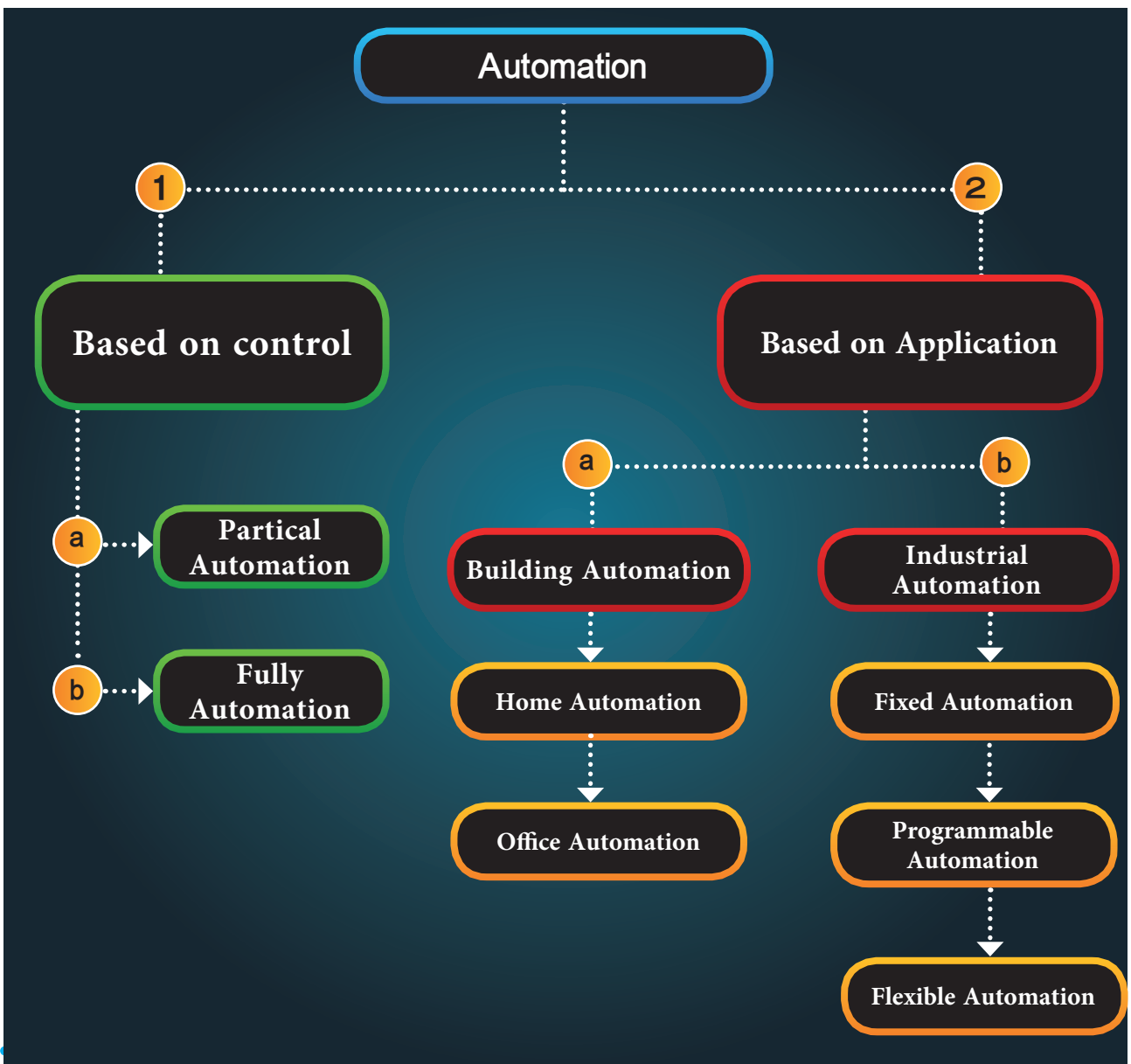

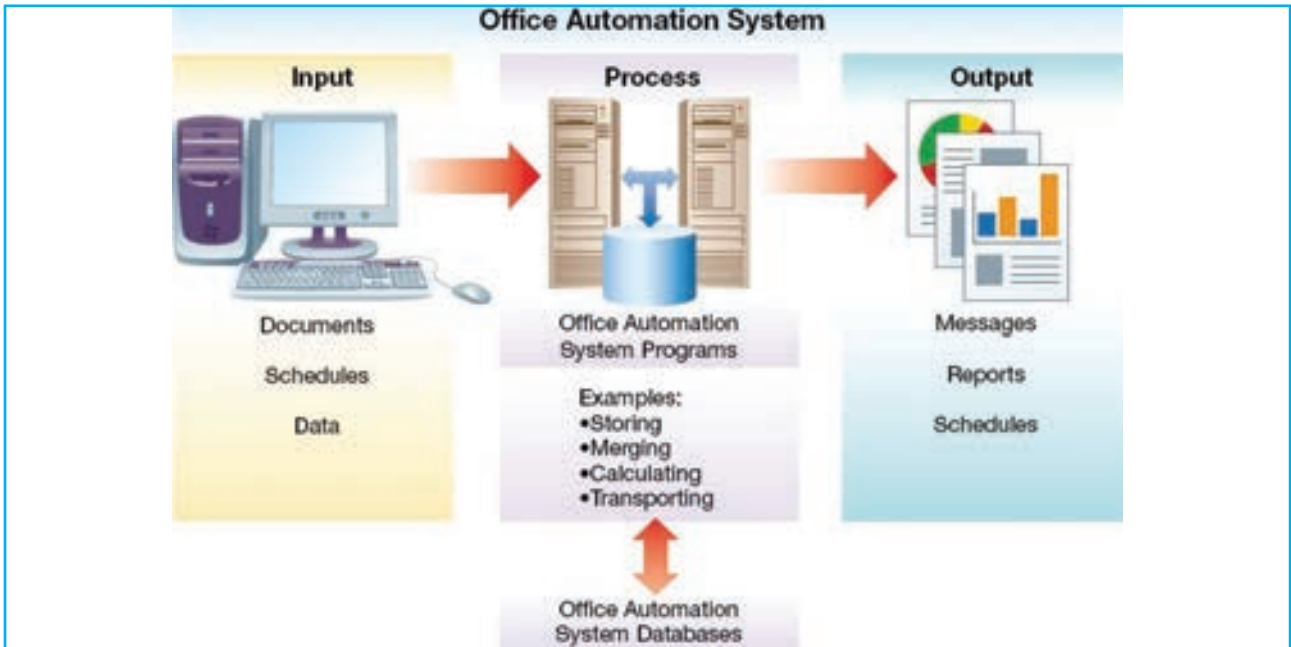

Office Automation

A. Fixed Automation (Hard Automation)

Fixed automation is a system in which the sequence of processing (or assembly) operations is **fixed** by the equipment configuration.

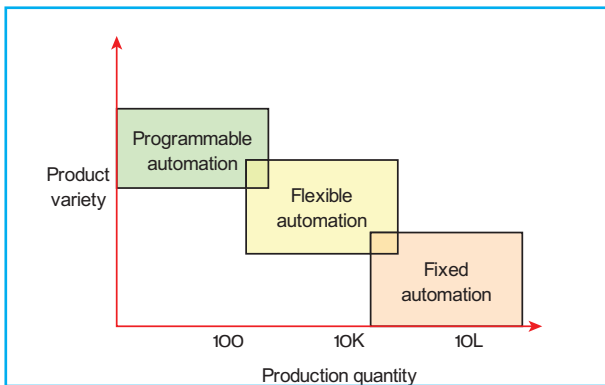

Advantages

1. The movement of parts is very fast and efficient
2. Very high efficiency
3. Unit cost is low

Disadvantages

1. High initial investment
2. Inflexibility

B. Programmable Automation

The word “Programmable” means that one set of task can be easily switched over to another set by changing the computerized instructions.

- i. Computer Aided Design (CAD)
- ii. Computer aided Manufacturing (CAM)
- iii. Computer Integrated Manufacturing (CIM)

Advantages

- For large batches the unit cost is low
- The change in product can be dealt with flexibility

Disadvantages

- Unit cost, as compared to fixed automation is high
- Long setup time is required for new product

C Flexible Automation (Soft Automation)

It has the capability of producing a variety of parts with minimal change over time from one part to the next.

Advantages

- Customized products
- Design variations can be dealt with flexibility
- Parts with complex shapes can be produced.

Disadvantages

- High initial investment
- Unit cost is relatively high

10.3 Needs for Industrial Automation

- To increase the labour productivity
- To improve the product quality
- To reduce the labour or production cost
- To reduce routine manual tasks
- To improve safety
- To assist remote monitoring

10.4 The advantages of automation

- Increased throughout productivity.
- Improved quality or increased predictability of quality
- Reduce overall production cost
- Less floor area required
- Human fatigue is greatly minimized
- Replaces humans in tasks done in dangerous environments (i.e. fire, space, volcanoes, nuclear facilities, underwater, etc.)

- Reduces operation time and work handling time significantly.
- Reduce maintenance requirements
- Uniform components are produced

The disadvantages of automation

- Possible security threats/vulnerability due to increased relative susceptibility for committing errors.
- Unpredictable or excessive development costs.
- High initial cost.
- Displaces workers due to job replacement.
- Leads to further environmental damage and could compound climate change.

10.5 Applications

- Numerical Control Machines
- Automated production lines
- Automated assemble lines
- Robots in manufacturing
- Flexible manufacturing system
- Automation in Daily life



Father of automation

Nikola Tesla (1856 – 1943)

“Nikola Tesla” is called the father of automation. Year: 1856 – 1943. He was a Serbian – American inventor, Electrical engineer, Mechanical Engineer.

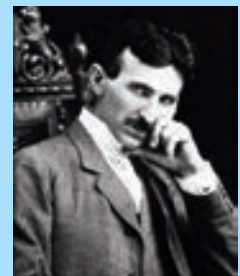

Nikola Tesla
(1856 – 1943)

10.6 Elements of automation

1. Source of power
2. Feedback control
3. Machine programming

ROBOTICS

10.7 Introduction

Robotics is an interdisciplinary branch of engineering and science that includes mechanical engineering, electronics engineering, computer science, and others. Many definitions have been suggested for what we call a robot. (The word may conjure up various level of technological specification, ranging from a simple material handling device to a humanoid). It is widely accepted that today's robots used in industries originated in the invention of programmed material handling device by George. C. Devol in 1954.



FIRST ROBOT IN THE WORLD

Father of Robotics Mr. George Devol

In 1954 George Devol invented the first digitally operated and a programmable robot called the Unimate. In 1956, Devol and his partner Joseph Engelberger formed the world's first robot company. In 1961, the first industrial robot, Unimate, went online in a General Motors automobile factory in New Jersey. Oct 16, 2017.



10.8 Definition-Robotics

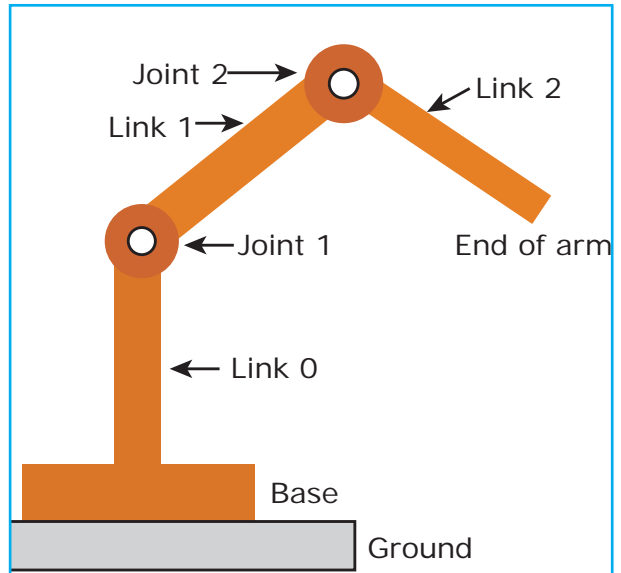

The latest technologies are used to develop machines that can substitute for humans and replicate human actions are called robot.

The robots are mainly used in dangerous environments, manufacturing process or where human cannot survive.

Autonomy

Interaction between the human control and machine motions.

1. Tele operation:
A human controls each movement, each machine actuator change is specified by the operator.
2. Supervisory:
A human specifies general moves or position changes and the machine decides specific movements of its actuators.
3. Task – Level – autonomy
The operator specifies only the task and the robot manage itself to compose it.
4. Fully autonomy
The machine will create and complete all its task without human interaction

10.9 Objectives of Industrial Robotics

1. To reduce production time
2. To minimize labour requirement
3. To raise the quality level of products
4. To increase the productivity
5. To improve existing manufacturing processes.

10.10 Advantages

1. Lifting and moving heavy objects
2. Working in holistic environment
3. Providing repeatability and consistency

4. Working during unfavourable hours
5. Performing dull or monotonous jobs
6. Increasing productivity and safety
7. Achieving more accuracy than human beings

Disadvantages

- The robots lack capability to respond in emergencies
- The initial and installation cost of equipment high
- They replace human workers, thus causing unemployment.

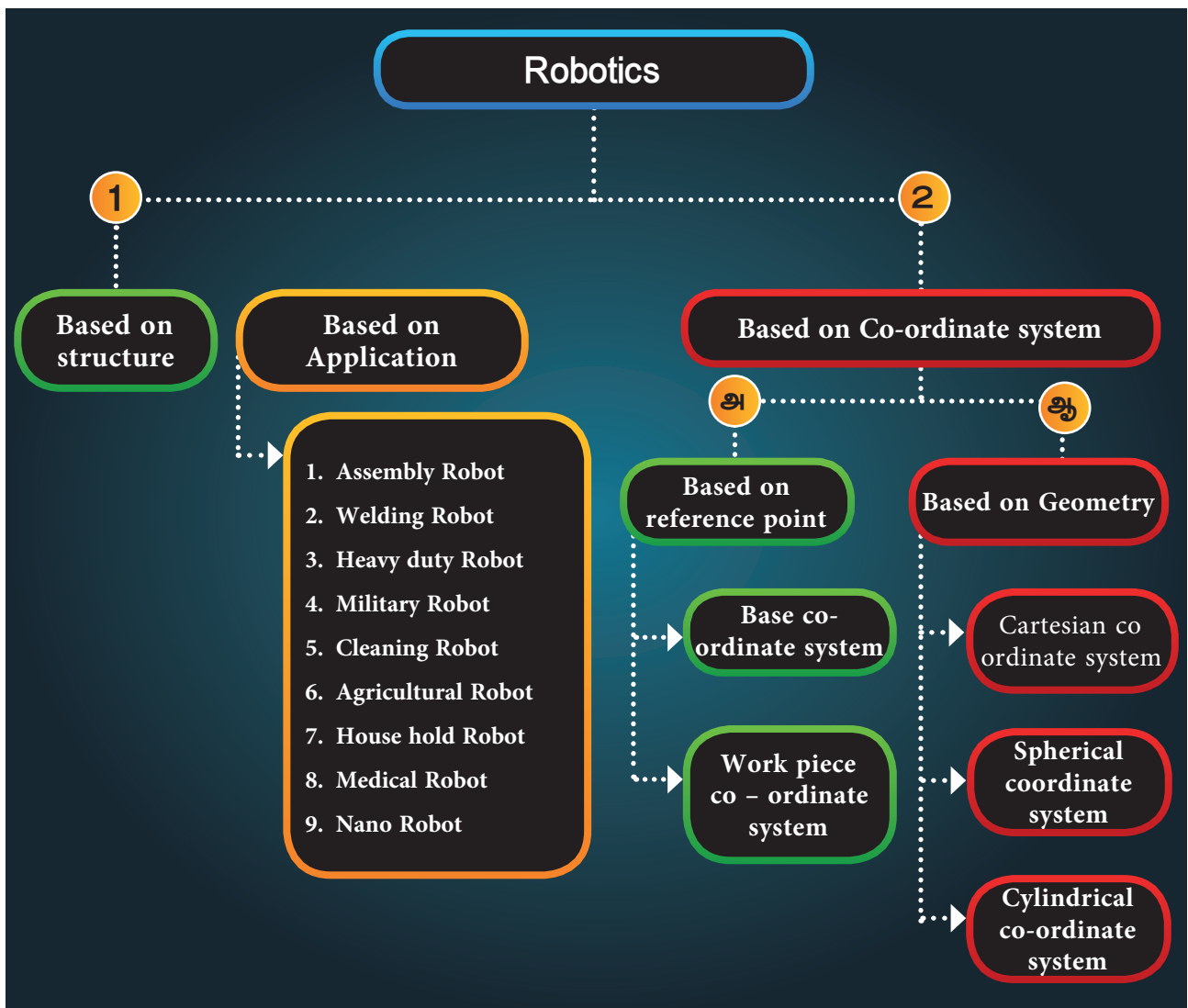

10.11 Three Main components of robots

1. Mechanical Components
2. Electrical components
3. Computer programming code

BASIC PRINCIPLE OF ROBOTICS

10.12 Asimov Laws of robotics

1. A robot must not injure a human being or, through inaction, allow a human being to come harm.
2. A robot must obey the orders given it by human being except where such orders would conflict with first law.
3. A robot must protect its own existence as long as such protection does not conflict with the first law or second law.

Mr. Isaac Asimov (1920 - 1992)

Isaac Asimov was an American writer and professor of biochemistry at Boston University. He was known for his works of science fiction and popular science. He was a prolific writer who wrote (or) edited more than 500 books and an estimated 90,000 letters and postcards.



10.13 Need of Robotics

- To improve the quality of products
- To reduce the preparation time
- To reduce the rejection rate and waste
- Higher flexibility of product type and variation

- Skilled labour shortage
- Rising cost
- Pressure to increase production rates to complete market.

Functions of Robotics

It can be classified into three areas

1. “Sensing” the environment by external sensors.
Example: Vision, Voice, Touch, Proximity, and so on
2. “Decision making” based on the information received from the sensor
3. “Performing” the task decided.

10.14 Types of Robots

1. Based on structure
2. Based on application
 - a. Assembly robot
 - b. Welding robot
 - c. Heavy duty robot
 - d. Military robot
 - e. Hospital robot
 - f. Cleaning robot
 - g. Agricultural robot
 - h. Medical robot
 - i. House hold robot
 - j. Nano robot
3. Based on coordinate system,
 - a. Base on the reference point
 - i. Base coordinate system
It is located at the base of the robot
 - ii. The work piece coordinate system
It is related to the work piece and is often the best one for programming the robot.

- b. Based on geometry
 - i. Cartesian coordinate system
 - ii. Cylindrical coordinate system
 - iii. Spherical coordinate system

- 3. It is also used in factories to build things like cars, candy bars and electronics

10.15 Applications of Robotics

1. Most robots today used to do repetitive actions or jobs considered too dangerous for human
2. It is ideal for going into a building that has a possible bomb

10.16 Parts of robots

1. The control system is – also known as the “brain” of Robot which is run by a computer program.
2. Mechanical parts – motors, pistons, grippers, wheels, and gears that

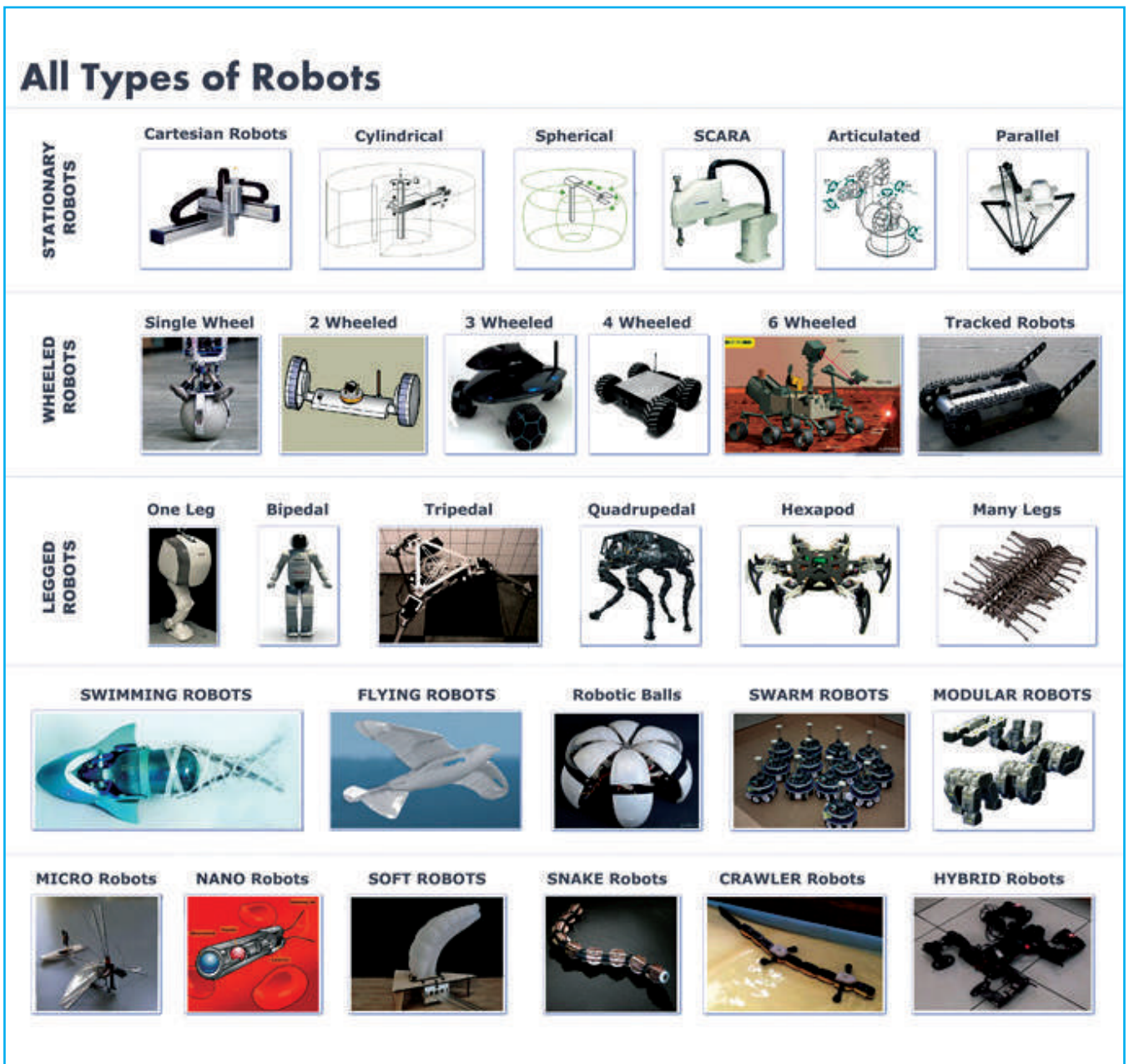

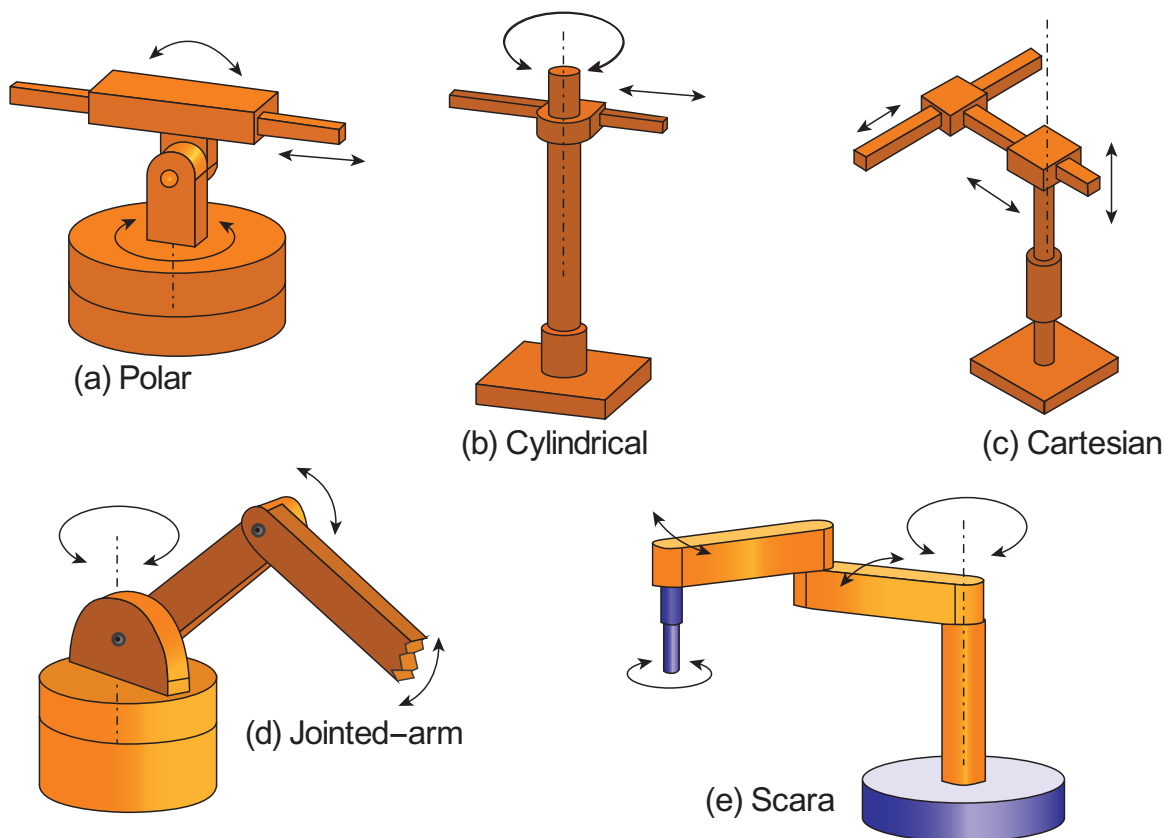

Robot Coordinate System

make the robot move, grab, turn, and lift....

3. Sensors – to tell the robot about its surroundings

10.17 Materials used for robots

Following are some of the plastics most frequently used as rigid structural materials.

1. Polystyrene
2. Plexiglass
3. Rigid PVC
4. ABS plastic
5. Polycarbonate
6. Polyethylene and polypropylene
7. Nylon

ACTIVITIES

1. Buying the Robotoys and give practice for dismantling and assembling the parts.
2. Students to know about the functioning of parts of robot.
3. How to operate the electric equipments in home and offices through the cellphone.

Questions

Part I.

Choose the correct option 1 Mark

1. “Centralized control automation” belongs to
 - a. Building automation system
 - a. Industrial automation system
 - a. Standard automation system
 - a. Partial automation system
2. The basic principles of Robot is formed by
 - a. Asimov
 - a. Hectare
 - a. George devil
 - a. Joseph rengal Berger
3. The brain of the Robot is called _____
 - a. Sensor
 - a. Control system
 - a. Piston
 - a. Gears
4. The part which receives the commands and send to the control system in Robot is
 - a. Control system
 - a. Gears
 - a. Sensor
 - a. Piston



Part II.

Answer the following questions in one or two sentences 3 Marks

5. What is meant by “Automation”?
6. What are the different types of automation?
7. What are various types of “Based on control”? of automation
8. Mention the types of “Based on Application” of automation
9. What is the purpose of Robots?

Part III.

Answer the following questions in about a page 5 Marks

10. What are the reasons for automation needed in industrial field?
11. What are the applications of automation?
12. What are the needs of robot?

Part IV.

Answer the following Questions in detail. 10 Marks

13. Mention the merits and demerits of automation.
14. Explain the parts of robots. What are the materials required to make robots?

TIME: 2.30 HOURS

MARKS: 90

PART –A**Choose the correct option**

15 x 1 = 15

- The inventor of lathe is
 - Henry maudslay
 - Eli whitney
 - James nasmith
 - Michael faraday
- A part used for taper turning
 - Cross – slide
 - Compound rest
 - Saddle
 - Apron
- The lip clearance angle of a drill is
 - 59⁰
 - 118⁰
 - 12⁰ to 15⁰
 - 135⁰
- The groove in the body of the drill is
 - V-shape groove
 - U-shape groove
 - Flute
 - Straight shape groove
- The operation mainly done in a shaping machine is
 - Turning
 - Drilling
 - Machining a flat surface
 - Thread cutting
- The part involved in reciprocation by quick return is
 - Table
 - Ram
 - Saddle
 - Crossrail
- The heat generated during dry grinding process will be
 - 20⁰ c
 - 1000⁰ c
 - 2000⁰ c
 - 1200⁰ c
- The hardest natural abrasive is
 - Sand stone
 - Emery
 - Diamond
 - Corundum
- In a milling machine, cutters are mounted on
 - Column
 - Spindle
 - Overhanging arm
 - Arbor
- In a milling machine, travelling of work table is controlled by
 - Saddle
 - Trip dogs
 - Cross – slide
 - Elevating screw

11. Maintenance done once a year is known as
 - a. Routine maintenance
 - b. Preventive maintenance
 - c. Breakdown maintenance
 - d. Corrective maintenance
12. Plastic welding is
 - a. Pressure welding
 - b. Resistance welding
 - c. Fusion welding
 - d. Arc welding
13. Impeller is a part found in
 - a. Reciprocating pump
 - b. Gear pump
 - c. Centrifugal pump
 - d. Vane pump
14. IC refers to
 - a. Information control
 - b. Instruction control
 - c. Internal control
 - d. Integrated circuit
15. "The brains of Robot" is
 - a. Sensor
 - b. Control system
 - c. Piston
 - d. Gears

PART – B

Answer any ten of the following Questions in one (or) two lines

10 x 3 = 20

16. Define "swing diameter" in lathe.
17. What is the use of "back gear" in lathe?
18. What are the special features of radial drilling machine?
19. Define "cutting speed" in drilling machine
20. What is the use of "clapper box" in shaping machine?
21. What is meant by "centre less grinding process"?
22. What is meant by "milling"?
23. What are the different types of "indexing head"?
24. What are the different types of maintenance?
25. Mention three types of flames in gas welding.
26. What are the different types of centrifugal pump?
27. What are the functions of input unit?
28. What are the types of automation based on application?

PART C

Answer any five of the following Questions for a Page

5 x 5 = 25

29. Mention the differences between turret and capstan lathe.
30. How do you specify the drilling machine?
31. List-out the types of shaping machine.
32. Explain with sketch the “truing of grinding wheel”
33. What are the differences between plain milling machine and universal milling machine.
34. Explain with sketch of “Greese Lubrication”.
35. Explain any two parts of gas welding with neat sketch

PART D

Answer the following Questions in detail.

2 x 10 = 20

36. Draw the diagram of a lathe and mention the parts
(or)
Explain the working principle of a “spindle” in drilling machine with neat sketch
37. Explain any two types of work holding devices in shaping machine with neat sketches
(or)
Explain the nomenclature of “Milling cutter” with neat sketch.

Basic Mechanical Engineering

PRACTICAL

CONTENTS

Basic Mechanical Engineering Practical

Ex. No.	Date	Title of the exercise	Page No	Teacher's signature
1.		Facing	190	
2.		Facing and plain turning	192	
3.		Step turning	194	
4.		Step turning and chamfering	196	
5.		Taper turning	199	
6.		Knurling	201	
7.		Grooving	203	

Basic Mechanical Engineering

Practical

NOTE

All dimensions are given in mm. The diameter of the round rod is given as 20 mm. The design of the exercises may be modified according to the size of the material available.

Points to be considered while working on a lathe

Some important points are to be considered before setting on to work on a lathe. They are

1. The suitable method of holding different types of work according to their shape.
2. Selection of proper cutting speed according to the size, weight, material of the work and the type of the operation.
3. Selection of proper cutting tool.
4. Mounting of the selected tool on the tool post.

The following illustrations are given to provide a good idea of holding a work, cutting speed, types of tools and setting of the tool.

Holding of the work

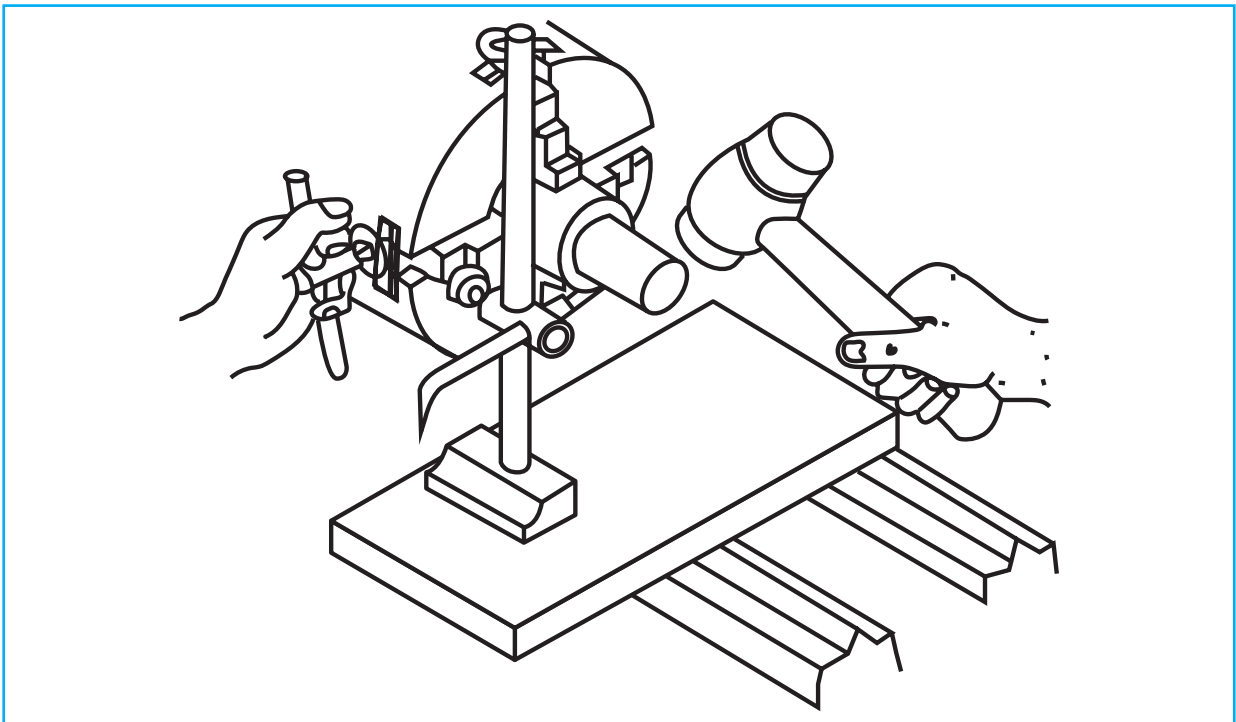

Holding of the work

The method of setting the work in a four jaw chuck with the help of a surface gauge

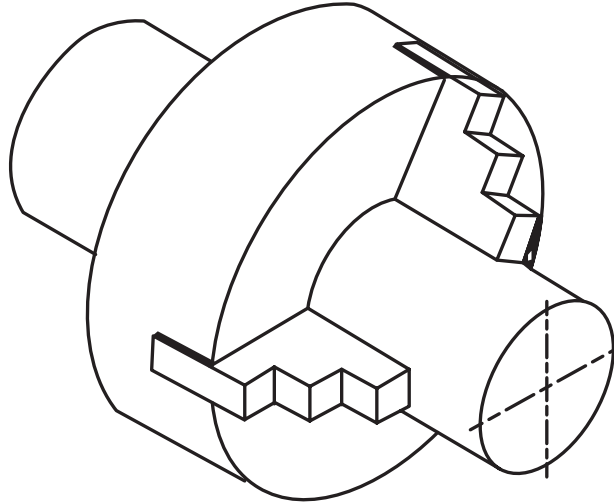

A cylindrical work is held in a three jaw chuck

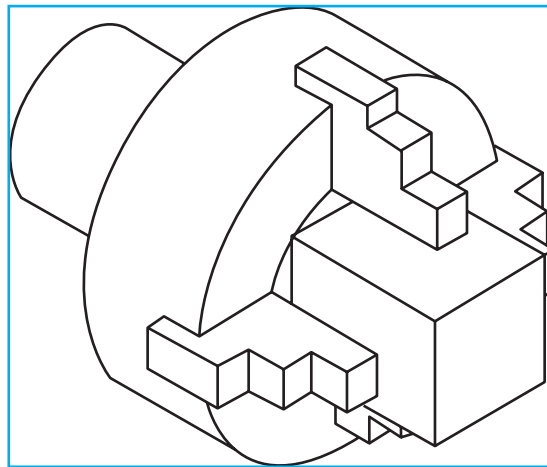

A rod of square section is held in four jaw chuck

Cutting speed

Speed can be defined as the distance an object moves in a particular time. In a lathe, the cutting speed is the distance travelled by a point on the outer surface of the work in one minute. It is expressed in meters per minute.

$$\text{Cutting speed} = \frac{\pi DN}{1000} \text{ m/min.}$$

Where,

‘d’ – is the diameter of the work in mm.

‘n’ – is the r.p.m. of the work.

$$\pi = 22/7 \text{ (or) } 3.14$$

Table showing cutting speed for various materials

Work Material	Cutting tool material		
	High speed steel	Tungsten steel	Stellite
Mild steel	30 m/min	80 m/min	58 m/min
High carbon steel	26 m/min	65 m/min	50 m/min
Cast steel	15 m/min	80 m/min	42 m/min
Cast iron	22 m/min	80 m/min	50 m/min
Aluminium	90 m/min	400 m/min	330 m/min
Brass	61 m/min	200 m/min	33 m/min

Tools used in a lathe

A. According to the construction. The lathe tools are classified into three types

1. Solid tool
2. Brazed tipped tool
3. Tool bit and tool holders

B. According to the operation to be performed, the cutting tools are classified as

1. Turning tool
2. Thread cutting tool
3. Facing tool
4. Forming tool
5. Parting tool
6. Grooving tool
7. Boring tool
8. Internal thread cutting tool
9. Knurling tool

C. According to the direction of feed movement, the following tools are used

1. Right hand tool
2. Left hand tool
3. Round nose tool

Method of mounting the cutting tool on the tool post

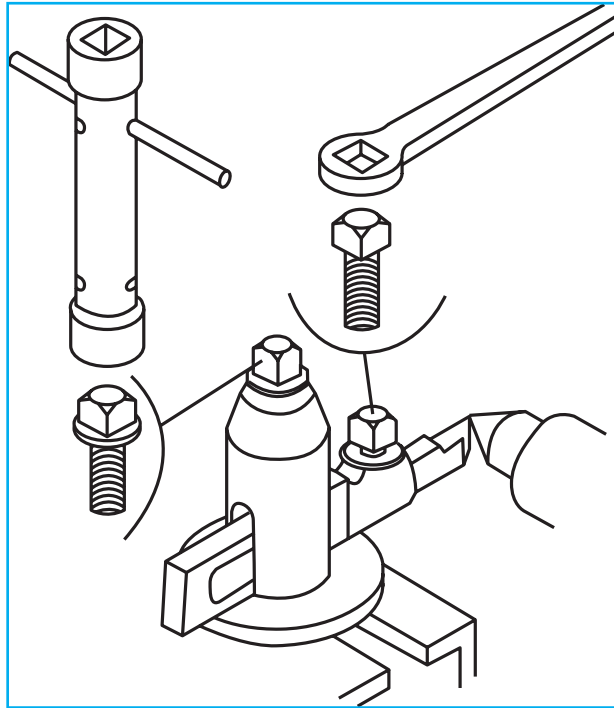

Correct method

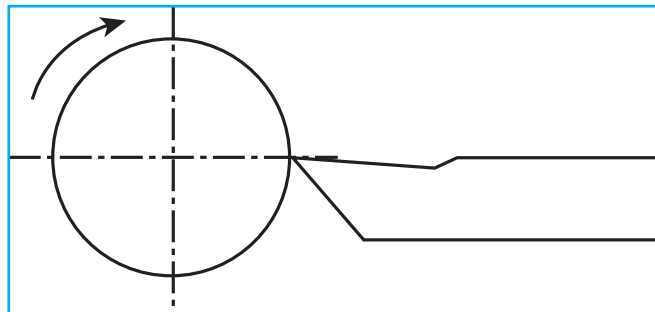

The cutting edge of the cutting tool is positioned exactly aligned to the axis of the lathe spindle.

Incorrect method-1

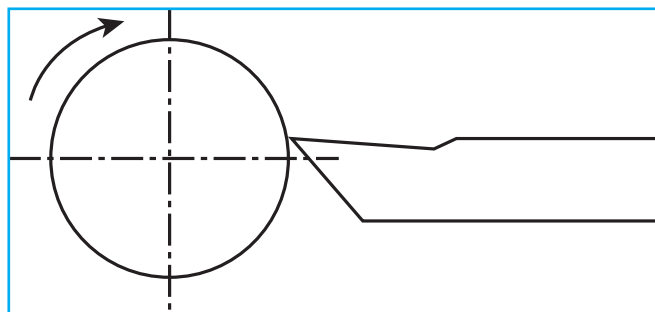

If the cutting edge of the cutting tool is positioned above the axis of the lathe spindle, the front clearance surface of the tool drags on the work. The cutting edge loses its cutting capacity due to wear.

Incorrect method-2

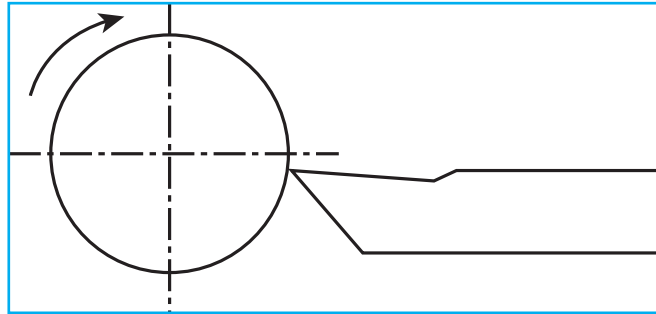

If the cutting edge of the cutting tool is positioned above the axis of the lathe spindle, the cutting edge loses its keenness. When the tool is provided with depth of cut, the work rides over the tool. The cutting edge may be broken and the work surface is damaged.

Types of toolposts

Single screw toolpost

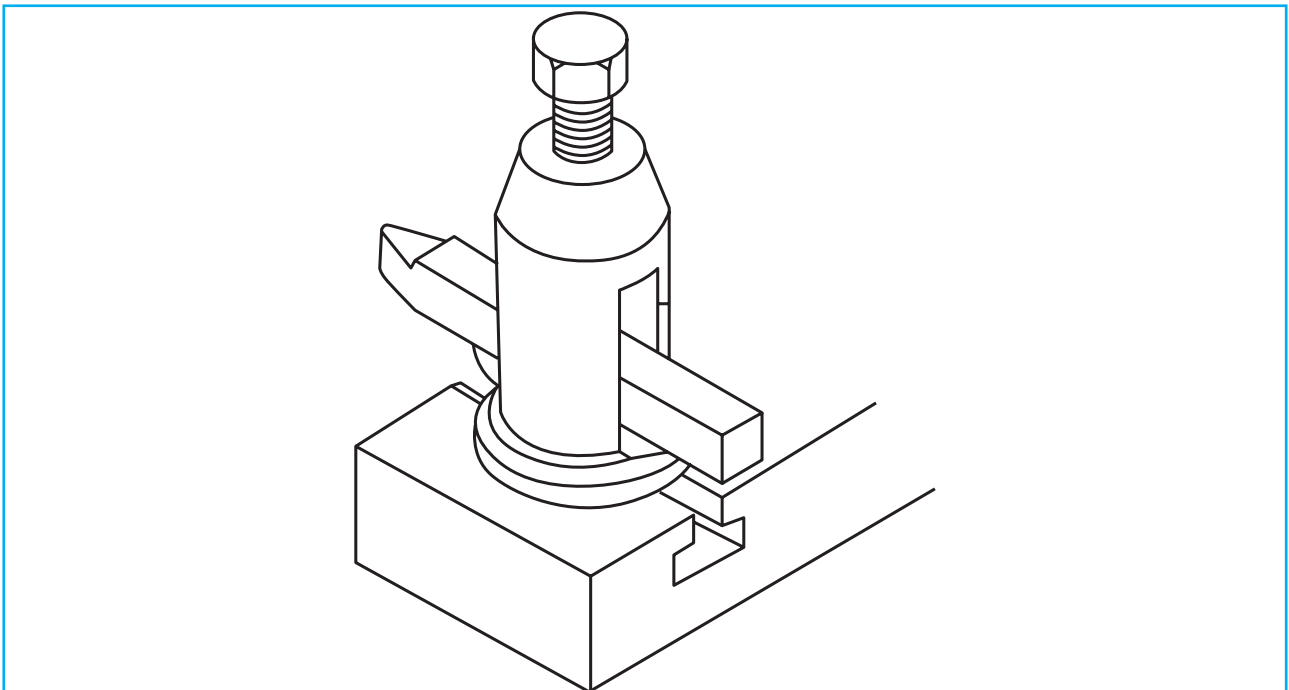

Four way toolpost

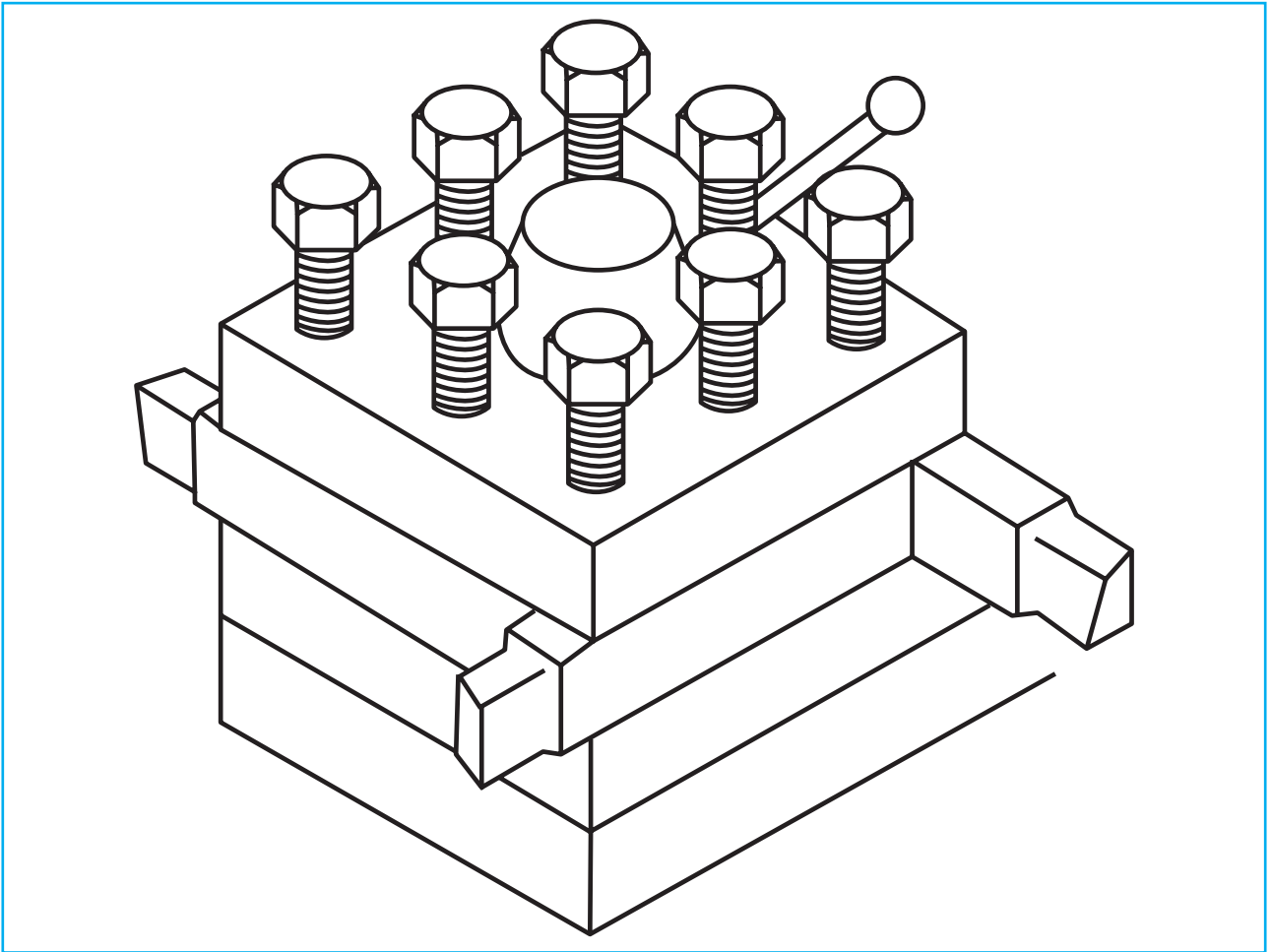



Facing

Aim

- To machine a flat surface on the face of the given round rod (Facing)

Required instruments

1. Facing tool
2. Chucky key
3. Tool holder
4. Steel rule
5. Vernier Caliper
6. Surface gauge

Tool setting

A facing tool is mounted on the toolpost and its cutting edge is set exactly aligned to the axis of the lathe spindle. The compound rest is set at 0° mark.

Holding of the work

1. The metal piece to be machined is held in the chuck of the lathe.
2. Surface gauge is used to check whether the work is held aligning with the lathe axis.

Exercise – 1

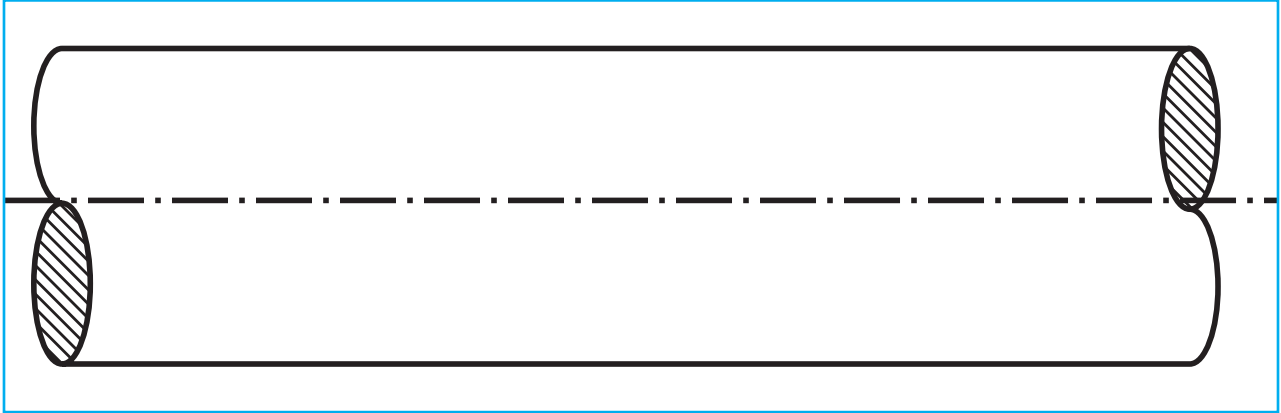

Operation – 1

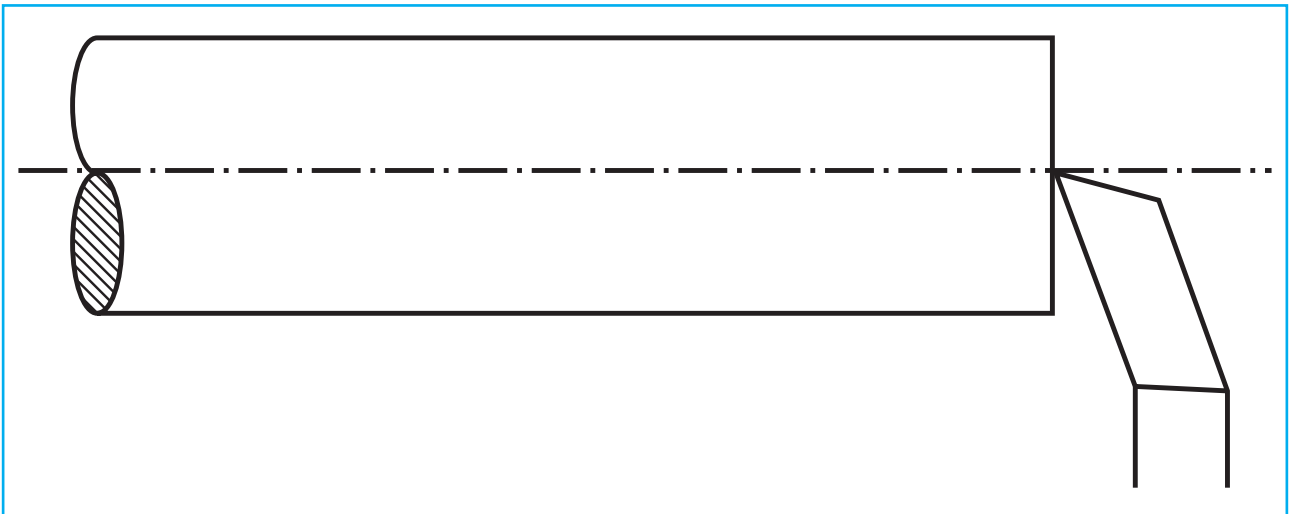

Selection of cutting speed

$$\text{Cutting speed} = \frac{\pi DN}{1000} \text{ m/min.}$$

The above formula is used to arrive at a proper cutting speed for machining and the spindle speed is adjusted suitably.

Procedure

The lathe is switched on and the facing tool mounted on the toolpost is given feed by the cross-slide perpendicular to the lathe axis. A flat surface on the face of the work is generated.

Result

The finished piece of work is sent for inspection after the machining is over.



Facing & Plain Turning

Aim

- To machine a flat surface on the face of the given round rod (Facing) and to perform plain turning operation to produce a cylindrical part of given dimensions.

Required instruments

- | | |
|-----------------------|--------------------|
| 1. Facing tool | 6. Vernier caliper |
| 2. Plain turning tool | 7. Outside caliper |
| 3. Chuck key | 8. Inside caliper |
| 4. Tool holder | 9. Surface gauge |
| 5. Steel rule | |

Tool setting

A facing tool and a plain turning are mounted on the toolpost and their cutting edges are set exactly aligned to the axis of the lathe spindle. The compound rest is set at 0° mark.

Holding of the work

1. The metal piece to be machined is held in the chuck of the lathe.
2. Surface gauge is used to check whether the work is held aligning with the lathe axis.

Selection of cutting speed

$$\text{Cutting speed} = \frac{\pi DN}{1000} \text{ m/min.}$$

The above formula is used to arrive at a proper cutting speed for machining and the spindle speed is adjusted suitably.

Facing operation

The lathe is switched on and the facing tool mounted on the toolpost is given feed by the cross-slide perpendicular to the lathe axis. A flat surface on the face of the work is generated.

Exercise – 2

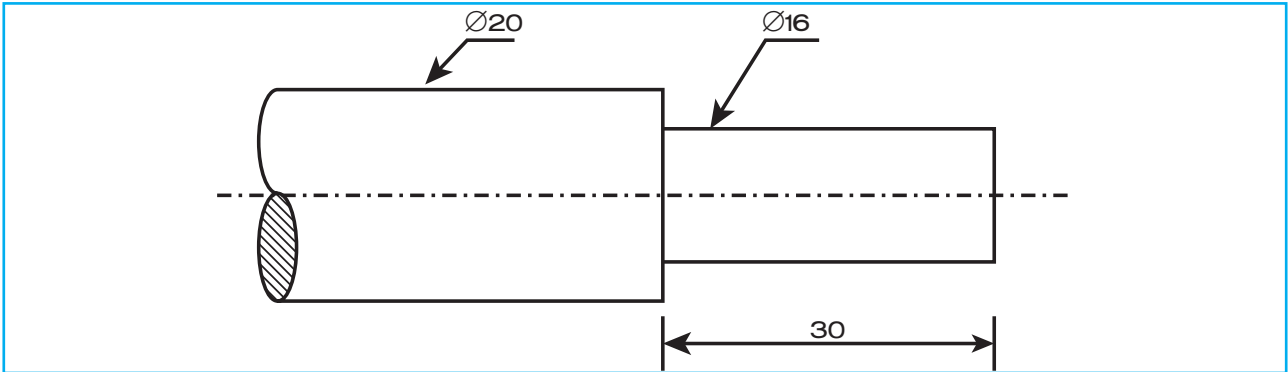

Operation – 1

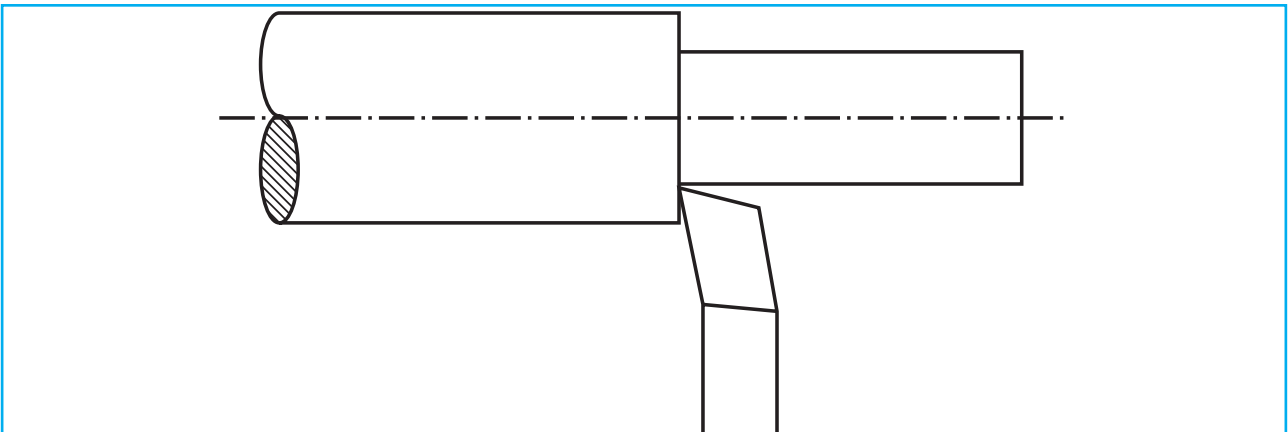

Marking

Marking is done on the work at the required point to indicate the length to be plain turned.

Procedure

1. The cross-slide is adjusted for required depth of cut and the lathe is switched on. The plain turning tool mounted on the toolpost is given feed by the carriage parallel to the lathe axis.
2. The above process is repeated until the required diameter is obtained. This is done by gradually moving the cross-slide after each cut.
3. During the process, the diameter of the work is checked with the help of outside caliper.
4. Finishing tool is used to obtain accurate dimensions of length and diameter.

Result

The finished piece of work is sent for inspection after the machining is over.



Step turning

Aim

- To perform step turning operation to produce a cylindrical part of given dimensions.

Required instruments

- | | |
|-----------------------|--------------------|
| 1. Facing tool | 6. Vernier caliper |
| 2. Plain turning tool | 7. Outside caliper |
| 3. chuck key | 8. Inside caliper |
| 4. Tool holder | 9. Surface gauge |
| 5. Steel rule | |

Tool setting

A facing and a plain turning tool are mounted on the toolpost and their cutting edges are set exactly aligned to the axis of the lathe spindle. The compound rest is set at 0° mark.

Holding of the work

1. The metal piece to be machined is held in the chuck of the lathe.
2. Surface gauge is used to check whether the work is held aligning with the lathe axis.

Selection of cutting speed

$$\text{Cutting speed} = \frac{\pi DN}{1000} \text{ m/min.}$$

The above formula is used to arrive at a proper cutting speed for machining and the spindle speed is adjusted suitably.

Facing operation

The lathe is switched on and the facing tool mounted on the toolpost is given feed by the cross-slide perpendicular to the lathe axis. A flat surface on the face of the work is generated.

Exercise – 3

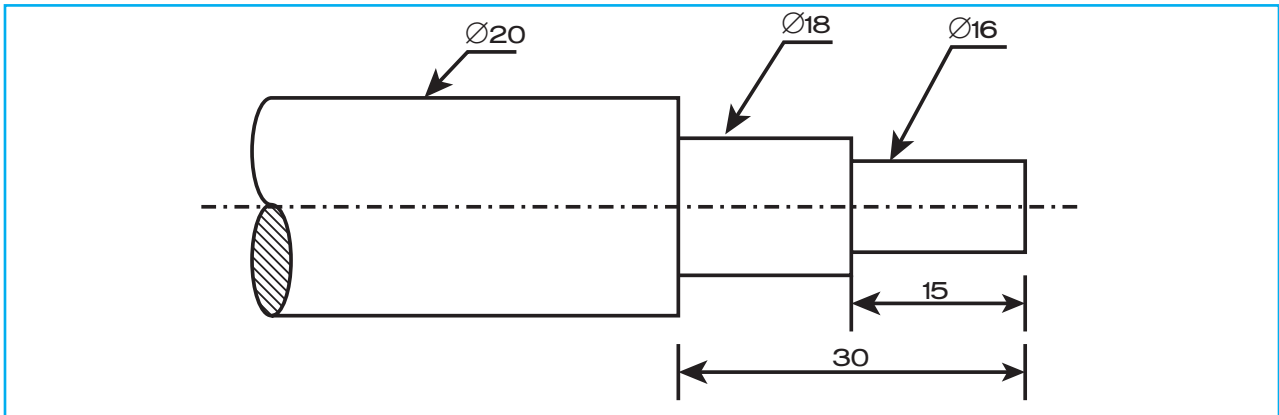

Operation – 1

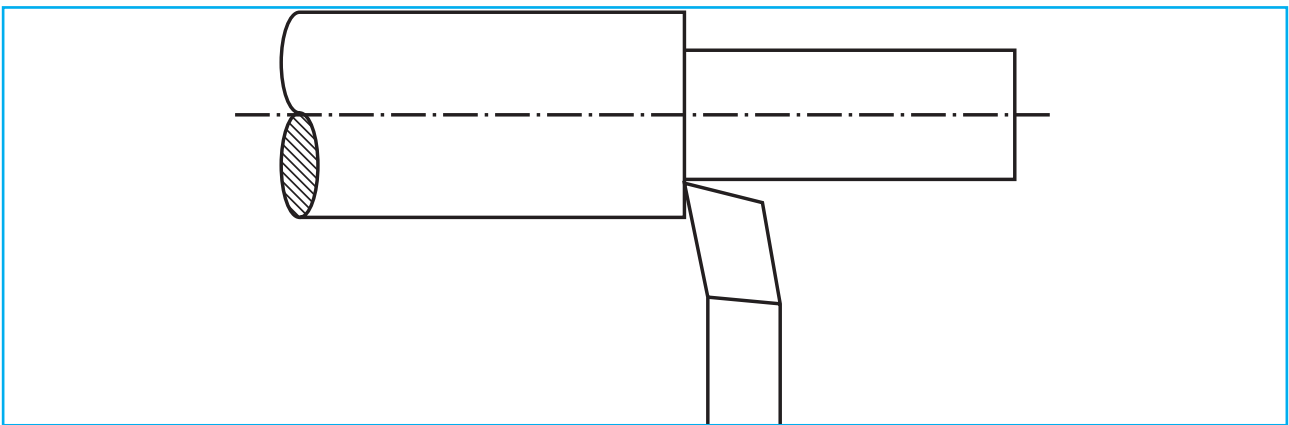

Marking

Marking is done on the work at the required point to indicate the length of the steps to be turned.

Procedure

1. The cross-slide is adjusted for required depth of cut and the lathe is switched on. The plain turning tool mounted on the toolpost is given feed by the carriage parallel to the lathe axis.
2. The above process is repeated until the required diameter is obtained. The length should be equal to the sum of the lengths of larger and smaller diameter.
3. When the larger step of given diameter is obtained, the tool is again fed parallel to the lathe axis to the given length of smaller step. Depth of cut is gradually given by the cross-slide to get the smaller step of required length and diameter.
4. Finishing tool is used to obtain accurate dimensions of length and diameter.
5. During the process, the dimensions of the work are checked with the help of outside caliper and inside calipers.

Result

The finished piece of work is sent for inspection after the machining is over.



Step Turning and Chamfering

Aim

- To perform step turning and chamfering operations to produce a cylindrical part of given dimensions.

Required instruments

- | | |
|-----------------------|--------------------|
| 1. Facing tool | 6. Steel rule |
| 2. Plain turning tool | 7. Vernier caliper |
| 3. Chamfering tool | 8. Outside caliper |
| 4. Chuck key | 9. Inside caliper |
| 5. Tool holder | 10. Surface gauge |

Tool setting

A facing tool, a plain turning tool and a chamfering tool are mounted on the toolpost and their cutting edges are set exactly aligned to the axis of the lathe spindle. The compound rest is set at 0° mark.

Holding of the work

1. The metal piece to be machined is held in the chuck of the lathe.

2. Surface gauge is used to check whether the work is held aligning with the lathe axis.

Selection of cutting speed

$$\text{Cutting speed} = \frac{\pi DN}{1000} \text{ m/min.}$$

The above formula is used to arrive at a proper cutting speed for machining and the spindle speed is adjusted suitably.

Exercise – 4

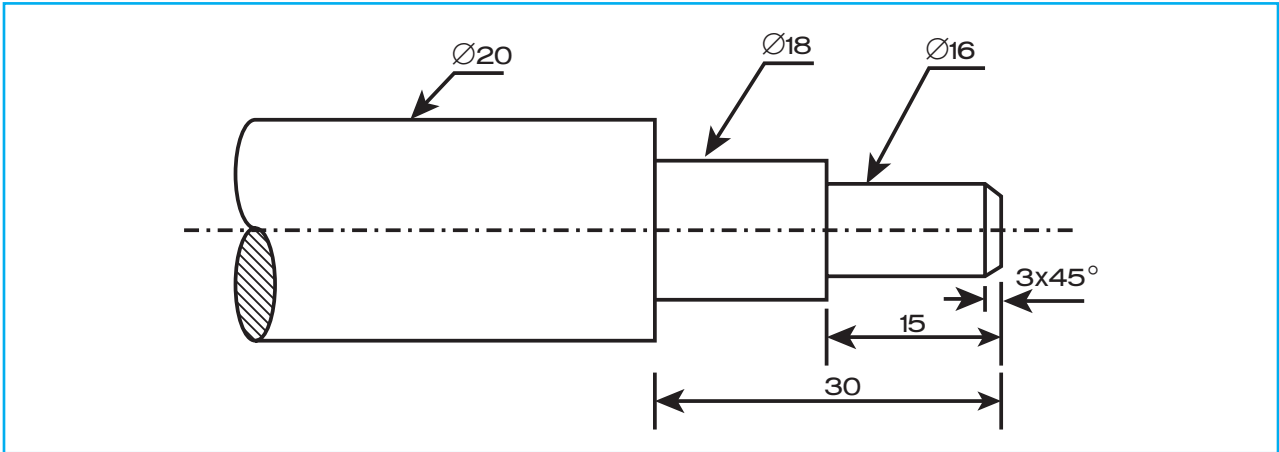

Operation – 1

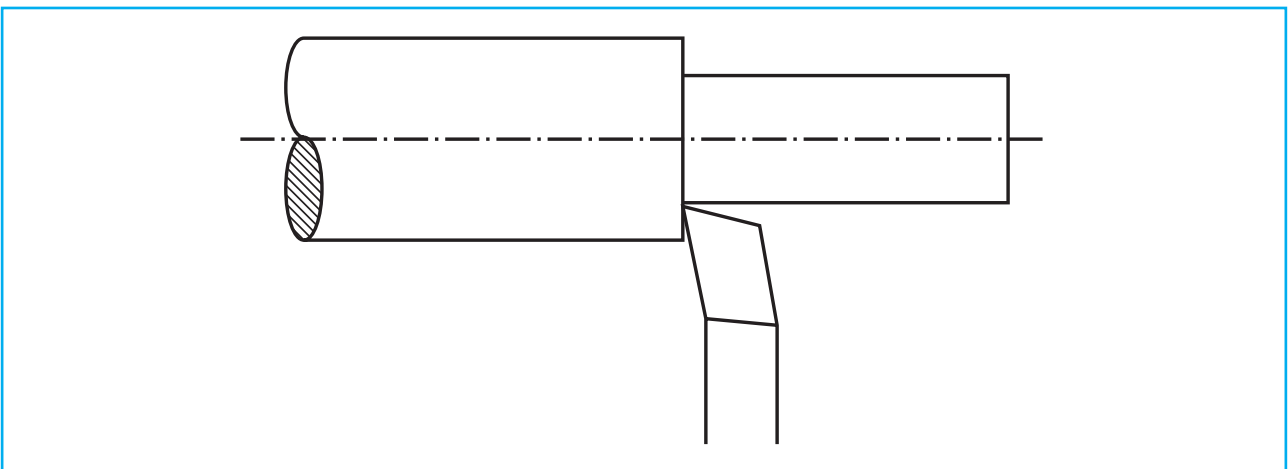

Facing operation

The lathe is switched on and the facing tool mounted on the toolpost is given feed by the cross-slide perpendicular to the lathe axis. A flat surface of the face of the work is generated.

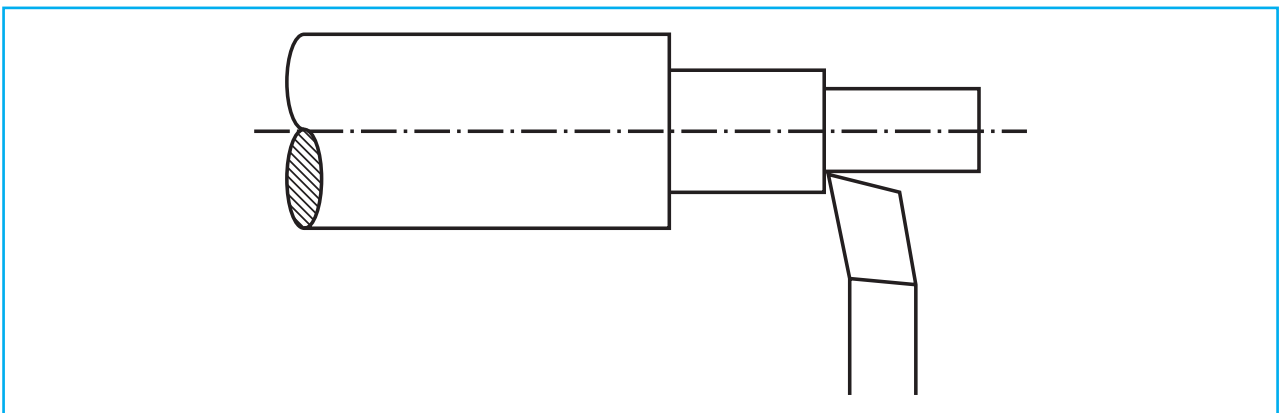

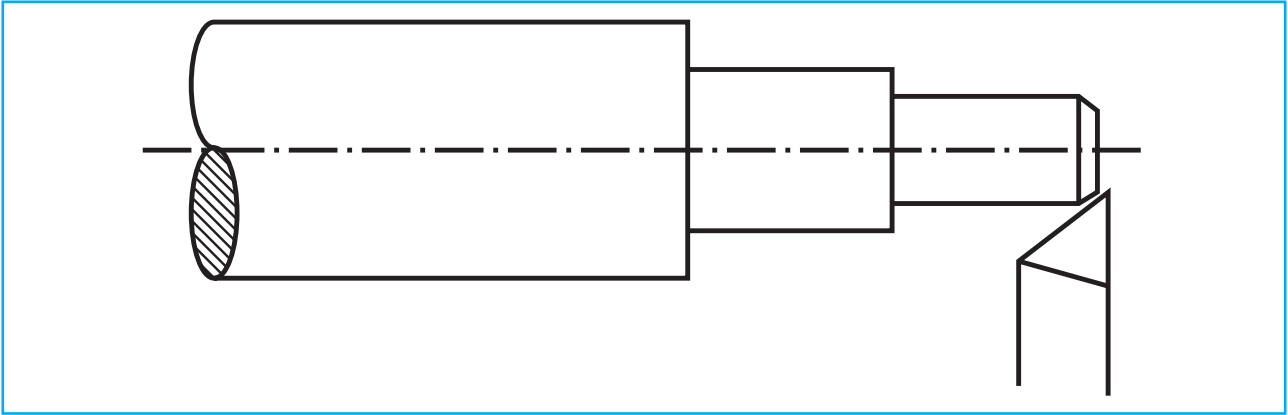

Marking

Marking is done on the work at the required point to indicate the length of the steps to be turned.

Procedure

1. The cross-slide is adjusted for required depth of cut and the lathe is switched on. The plain turning tool mounted on the toolpost is given feed by the carriage parallel to the lathe axis.
2. The above process is repeated until the given larger diameter is obtained. The length should be equal to the sum of the lengths of larger and smaller diameter. When the larger step of given diameter is obtained, the tool is again fed

parallel to the lathe axis to the given length of smaller step. Depth of cut is gradually given by the cross-slide to get the smaller step of required length and diameter.

3. During this process, the dimensions of the work are checked with the help of outside caliper and inside calipers.
4. Finishing tool is used to obtain accurate dimensions of length and diameter.
5. The chamfering tool (form tool) is set at the work at the required angle. Feed is given to the tool by the cross-slide to perform chamfering.

Result

The finished piece of work is sent for inspection after the machining is over.



Taper Turning

Aim

- To perform taper turning to produce a cylindrical part of given dimensions.

Required instruments

- | | |
|-----------------------|--------------------|
| 1. Facing tool | 6. Vernier caliper |
| 2. Plain turning tool | 7. Outside caliper |
| 3. Chuck key | 8. Inside caliper |
| 4. Tool holder | 9. Surface gauge |
| 5. Steel rule | |

Tool setting

A facing tool and a plain turning tool are mounted on the toolpost and their cutting edges are set exactly aligned to the axis of the lathe spindle. The compound rest is set at 0° mark.

Holding of the work

1. The metal piece to be machined is held in the chuck of the lathe.
2. Surface gauge is used to check whether the work is held aligning with the lathe axis.

Selection of cutting speed

$$\text{Cutting speed} = \frac{\pi DN}{1000} \text{ m/min.}$$

The above formula is used to arrive at a proper cutting speed for machining and the spindle speed is adjusted suitably.

Facing operation

The lathe is switched on and the facing tool mounted on the toolpost is given feed by the cross-slide perpendicular to the lathe axis. A flat surface on the face of the work is generated.

Exercise – 5

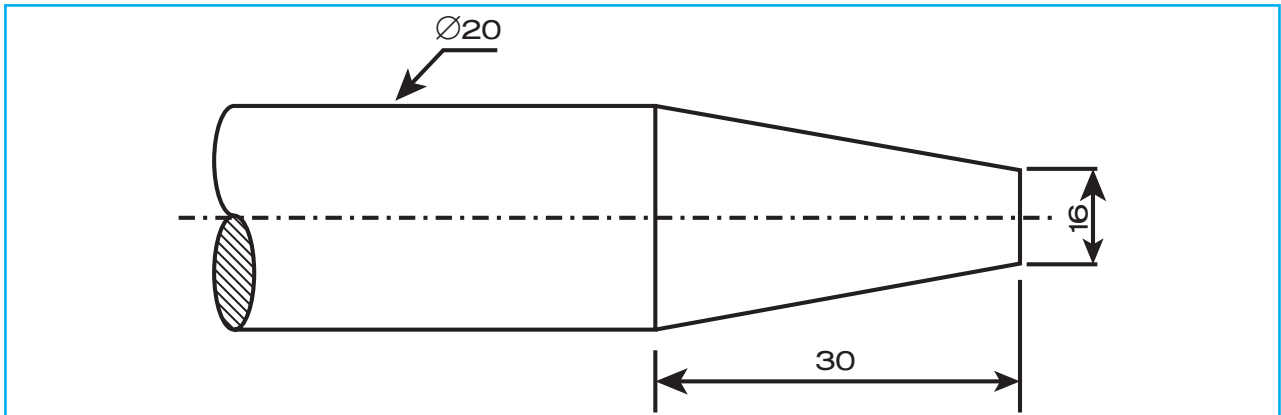

Operation – 1

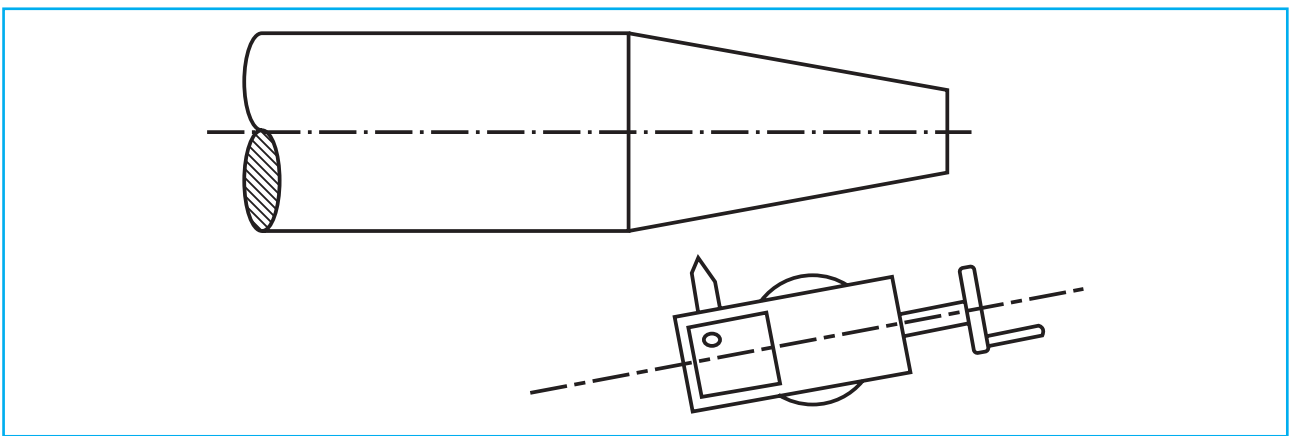

Marking

Marking is done on the work at the required point to indicate the length of the steps to be turned.

Procedure

1. The angle (θ) through which the compound slide is to be swiveled is calculated by the formula

$$\tan \theta = \frac{D-d}{2l}$$

where

'D' is the larger diameter

'd' is the smaller diameter and

'l' is the length of the taper

2. The compound slide is swiveled to the angle calculated as above.

3. The depth of cut is set by adjusting the cross-slide.
4. The plain turning tool mounted on the toolpost is given feed by the compound slide at the required angle to the lathe axis.
5. The above process is repeated until the taper required length is obtained. This is done by adjusting the cross-slide for depth of cut and compound slide for feed.
6. While doing so, feed is provided from smaller diameter to larger diameter.

Result

The finished piece of work is sent for inspection after the machining is over.



Knurling

Aim

- To perform knurling operation on a cylindrical part of given dimensions.

Required instruments

- | | |
|-------------------------|--------------------|
| 1. Facing tool | 6. Steel rule |
| 2. Plain turning tool | 7. Vernier caliper |
| 3. Knurling tool holder | 8. Outside caliper |
| 4. Chuck key | 9. Inside caliper |
| 5. Tool holder | 10. Surface gauge |

Tool setting

A facing and a plain turning tool are mounted on the toolpost and their cutting edges are set exactly aligned to the axis of the lathe spindle. The compound rest is set at 0° mark.

Holding of the work

1. The metal piece to be machined is held in the chuck of the lathe.
2. Surface gauge is used to check whether the work is held aligning with the lathe axis.

Selection of cutting speed

$$\text{Cutting speed} = \frac{\pi DN}{1000} \text{ m/min.}$$

The above formula is used to arrive at a proper cutting speed for machining and the spindle speed is adjusted suitably.

Facing operation

The lathe is switched on and the facing tool mounted on the toolpost is given feed by the cross-slide perpendicular to the lathe axis. A flat surface on the face of the work is generated.

Exercise – 6

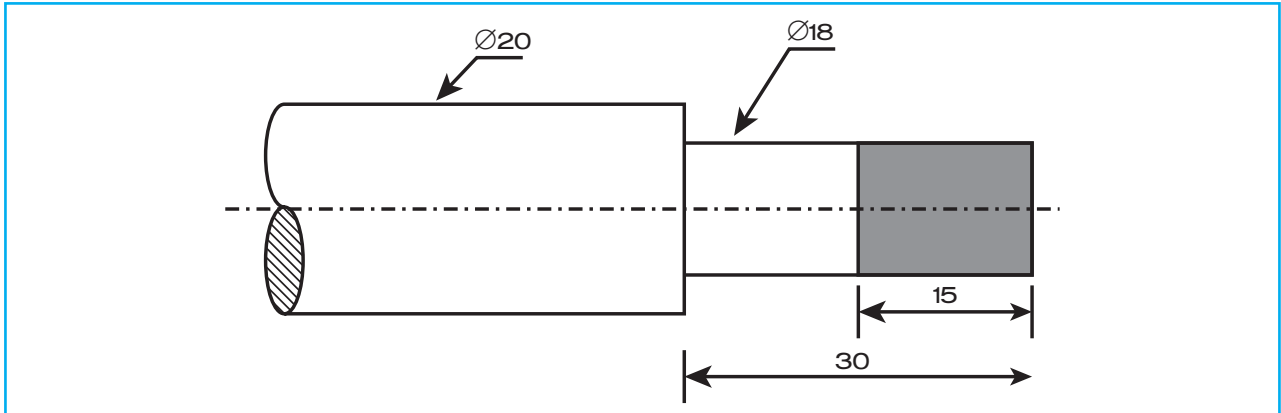

Operation – 1

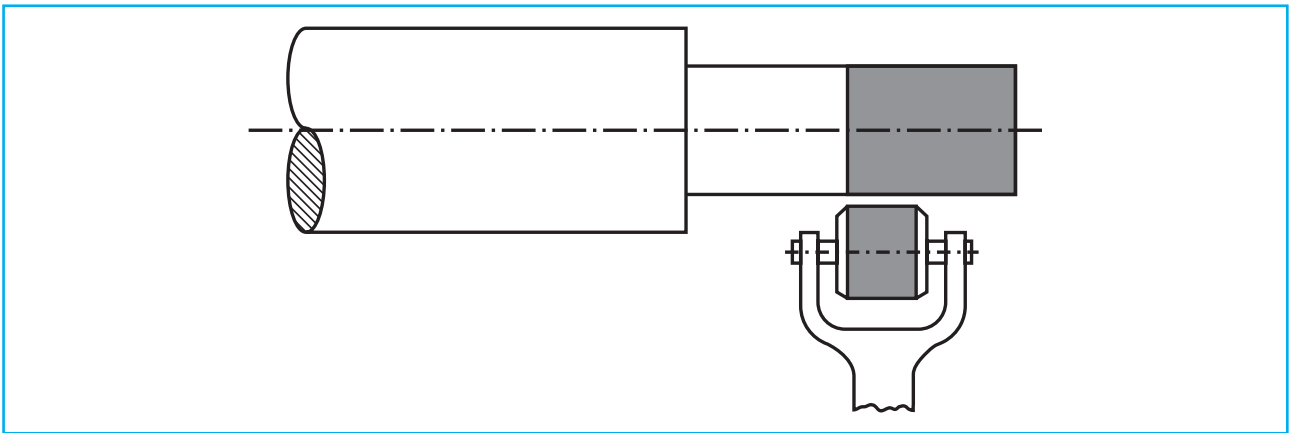

Marking

Marking is done on the work at the required points to indicate the length of the portion to be knurled.

Procedure

1. The cross-slide is adjusted for required depth of cut and the lathe is switched on. The plain turning tool mounted on the toolpost is given feed by the carriage parallel to the lathe axis.
2. The above process is repeated until the required diameter is obtained. This is done by the gradually moving the cross-slide after each cut.
3. During this process, the diameter of the work is checked with the help of outside caliper and inside caliper.

4. Finishing tool is used to obtain accurate dimensions of length and diameter.
5. A knurling tool holder has one or two knurling rolls fitted to it. It is fitted on the toolpost and pressed against the work rotating at a slower speed. The feed is given by the carriage parallel to the lathe axis.
6. The knurling tool holder is relieved from the work after the operation is performed for the required length.

Result

The finished piece of work is sent for inspection after the machining is over.



Grooving

Aim

- To machine a groove of given width and depth on a cylindrical part of given dimensions.

Required instruments

- | | |
|-----------------------|--------------------|
| 1. Facing tool | 6. Steel rule |
| 2. Plain turning tool | 7. Vernier caliper |
| 3. Parting tool | 8. Outside caliper |
| 4. Chuck key | 9. Inside caliper |
| 5. Tool holder | 10. Surface gauge |

Tool setting

A facing tool, a plain turning tool and a parting tool are mounted on the toolpost and their cutting edges are set exactly aligned to the axis of the lathe spindle. The compound rest is set at 0° mark.

Holding of the work

1. The metal piece to be machined is held in the chuck of the lathe.
2. Surface gauge is used to check whether the work is held aligning with the lathe axis.

Selection of cutting speed

$$\text{Cutting speed} = \frac{\pi DN}{1000} \text{ m/min.}$$

The above formula is used to arrive at a proper cutting speed for machining and the spindle speed is adjusted suitably.

Facing operation

The lathe is switched on and the facing tool mounted on the toolpost is given feed by the cross-slide perpendicular to the lathe axis. A flat surface on the face of the work is generated.

Exercise – 7

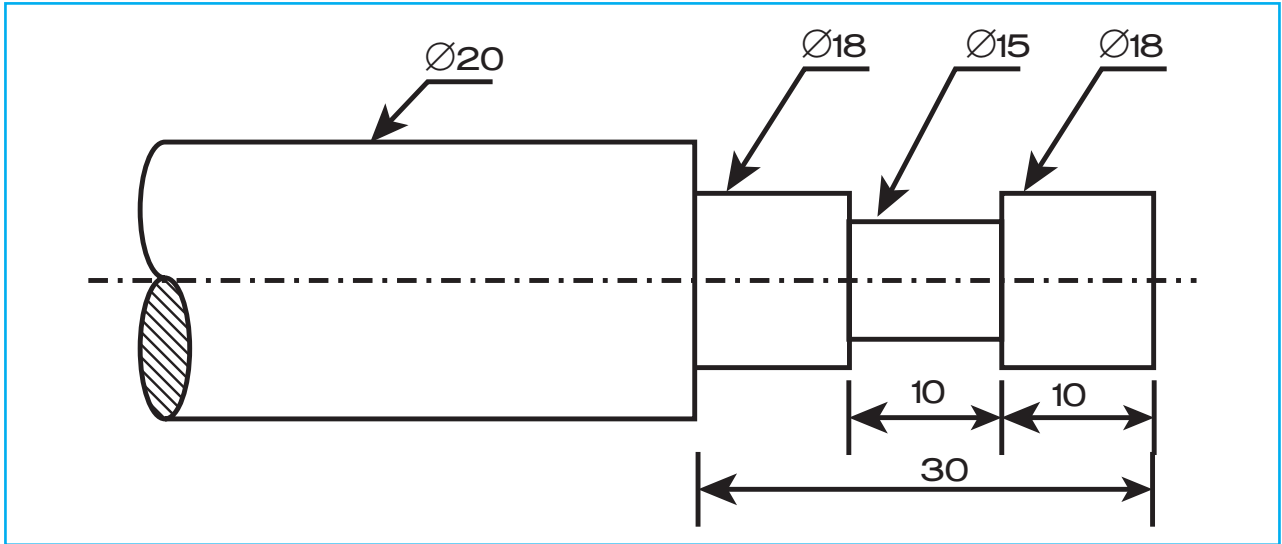

Operation – 1

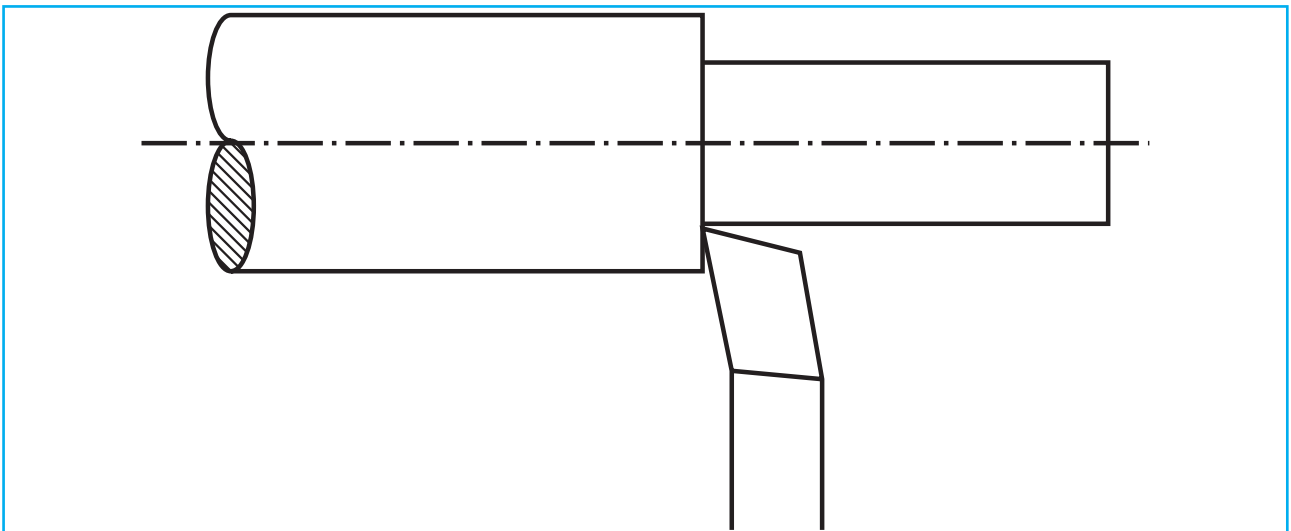

Operation – 2

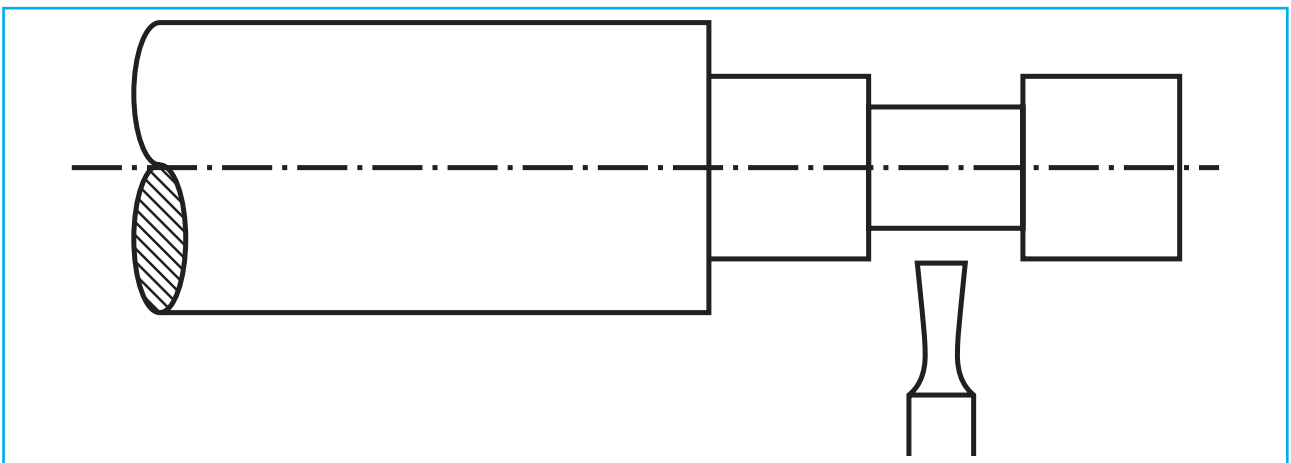

Marking

Marking is done on the work at the required points to indicate the location of the groove after plain turning is performed to the required diameter.

Procedure

1. The cross-slide is adjusted for required depth of cut and the lathe is switched on. The plain turning tool mounted on the toolpost is given feed by the carriage parallel to the lathe axis.
2. The above process is repeated until the required diameter is obtained. This is done by the gradually moving the cross-slide after each cut.
3. During this process, the diameter of the work is checked with the help of outside caliper and inside caliper.

4. Finishing tool is used to obtain accurate dimensions of length and diameter.
5. The parting tool is brought to the marked location of the groove. The depth of cut is set by the cross-slide and the feed is provided by moving the carriage slowly between the marked points.
6. The above process is repeated until the required depth and the length of the groove is obtained.

Result

The finished piece of work is sent for inspection after the machining is over.

C. Ravi,

3, Babu Nagar, Jolarpettai, Vellore District – 635 851.

Educational Qualification

- Passed SSLC, March 1987 in Government Boys Hr. Secondary School, Jolarpet.
- Passed +2 – HSC – Vocational – General Machinist section (Now called as ‘Basic Mechanical Engineering’) in April, 1989 at Government boys Hr Sec School, Natrampalli, Vellore District – 635 852.
- Passed B.Sc., (Maths) at Majharull Ulum college, Ambur in vellore Dt.

Professional Experience

- Worked as Technical Assistant at J.T.C. Network Company, Singapore in 1994-1997.
- Worked as Technical Assistant at private construction company, Singapore in 1997-2003.
- In between 2003-2010, I became owner of brick industry and then worked as supervisor in R.K. International Private Ltd, Chennai.
- Worked as supervisor in Matrix Skill Development Company Jolarpet which selects man power for abroad in 2010-2016.
- I am running company known as “CRS agarbathies”, private Limited, Jolarpettai producing agarbathies with above 300 machineries and above 500 workers.
- I proud of my school so I built an auditorium of the value Rs. 4.5 lakhs for the use of students of Government Boys Hr. Sec. School, Natrampalli, Vellore District.

For the improvement of my life, my elementary education and Higher Secondary General Machinist Vocational course are very useful. Encouragement and advices of my vocational teacher Thiru. C. Ravivarman is always memorable in my life.

Declaration:

I hereby declare that all above are true to the best of my knowledge and I am doing my profession with interest and dedication.

Yours faithfully

C. Ravi
Jolarpet

A. Senthil Kumar,

**Sri Sakthi engineering, A-15,
Sidco Industrial Estate, Phase – 3,
Guindy, Chennai – 600 032.**

Educational Qualification:

- Passed HSC (+2) Vocational Course General Machinist (Now called as “Basic Mechanical Engineering) section with 72% mark in March 1991 in Government Boys Higher Secondary School, Arni, Thiruvannamalai District.
- Passed in Diploma in Mechanical engineering with 76% mark in 1994 at Meenakshi Ammal Polytechnic, Uttiramerur, chengalpet District.

Professional experience:

- My professional career starts with CNC machine trainer at two small industries in 1994-2007.
- I went to Japan country and worked as Design Engineer for one year in 2007.
- In between 2008-2013, I worked as Design Engineer in an American Company.
- From 2013, I am running small scale industry called as “Sree Sakthi engineering” in Guindy. I offer job opportunities for students those passed in HSC – Basic Mechanical Engineering.
- I always remember my Vocational teachers Thiru. N. Palanivelu and Thiru. C. Velmurugan for their part in my life. They taught me discipline, tiredless work and dedication. These are the factors used for improvement of my life.

Declaration:

I hereby declare that all above are true to the best of my knowledge and I always remember “work is workship”.

Yours faithfully

A. Senthilkumar

Chennai-32

M. Surya

No. 12 g1 Krishna Castle,
Color Homes TTK Nagar, West Tambaram,
Kanchipuram, Chennai – 600 045.

Educational qualification

- Completed my Higher Secondary Education in General Machinist Vocational Group in the year 2011 securing 70% marks in Boys Higher Secondary School, Vandavasi, Thiruvannamalai Dt.,
- Passed Bachelor of Technology in civil engineering branch in the year 2015 with securing 65% marks, Bharat Institute of Technology, Deemed University, Chennai.

Professional experience

- Started Man Power Agency at 2015 coordinate with Prestige company. Associated with AGS Constructions, Medavakkam worked as Manager during CASA Grande Project in 2016-17. A sole Proprietor of GS Constructions and Landscape, Chennai started in April 2018.

Skill Matrix

- Strength and Durability Properties Of Concrete By Using Florescent Light Tube Powder Replacing As Cement
- This project is strength and durability of concrete by using fluorescent light scrap comparing it with the conventional mix.

Area of Interests

- Site Engineer
- Designing field

Declaration

I here by declare that all the details provided above are true to the best of my knowledge and belief, and I bear the responsibility for the correctness of the above mentioned particulars.

Yours Truly,

M. Surya
Chennai-45

REFERENCES

1. “*Elements of Workshop Technology*” by S.K. Hajra choudhury and A.k.Hajra choudhury and Nirjhar Roy, Media promotors & publishers pvt. Ltd, Mumbai – 400 007.
2. “*Basic Mechanical Engineering*” by T.S. Rajan, New age International publishers, 3rd Edition.
3. “*Machine Tool Practices*” by Richard R. Kibbe and Roland O.Meyer, John.E.Neely, Werren.T. White, 8th Edition, publisher Name.Pearson/prentice Hall, upper saddle River, New Jersey, Columbus, ohio.
4. ‘*Welding*’ by A.C. Davies cambridge low price Edition, 10th Edition.
5. “*Welding and welding Technology*” by Richard.L. Little, Mc Graw Hill Education (India) Privated Ltd, New Delhi.
6. “*Fundamentals of Hydraulic Engineering*” by Alan L.Prasuhn, Oxford Univercity press.
7. “*Pumps & Hydraulics*” by Rex Miller, Mark Richard Miller, Harry Stewart published by wiley publishing Inc.
8. “*Hydraulics Laboratory Mannual*” by S.K. Likhi, New age International Publishers New Delhi – 110 002
9. “*Computer Numerical control Machining and Turning centers*” by Robert Quesada, published by pearson/prentice Hall, Upper saddle River, New Jersy, coloumbus, ohio.
10. “*Robotics and Industrial Automation*” by R.K. Rajput, s.chand & company Ltd, Ram Nagar, New Delhi – 110 055
11. “*Automation and Human performance theory and applications*” by Raja parasuraman and Mustapha Moulaua. Published by Lawrence Erlbaum Associates publishers Mahwah, New jersey.
12. “*Robotics*” by Ellen Thro published by Facts on File, Inc

Higher Secondary Class XII

Basic Mechanical Engineering - Theory & Practicals

List of Authors and Reviewers

Adviser & Expert

Dr. P. Kumar

Joint Director (Syllabus)
State Council of Education Research and Training Tamilnadu,
Chennai.

Domain Expert

Dr. P. Manivannan

Professor,
School of Aeronautics Science, Hindustan University,
Kelambakkam, Chennai.

Reviewer

S. Rajendra Boopathy

Professor,
Department of Mechanical Engineering,
Central Workshop Division, Anna University,
Chennai.

Academic Co-ordinator

A. Illangovan,

Assitant Professor,
(Dr. Radhakrishnan 'State Best Teacher' Awardee-2018)
SCERT, Chennai-06.

P. Malarvizhi,

BT Assitant, (Mathematics),
SCERT, Chennai-06.

Art and Design Team

Layout Designing and Illustration)

Arockiam Felix Chennai

Wrapper Design

Kathir Arumugam

Quality Control

Gerald Wilson
Pakkirisamy Annadurai

Coordination

Ramesh Munisamy

Authors List

C. Ravivarman

(Dr. Radhakrishnan 'State Best Teacher' Awardee-2015)
Vocational Teacher,
Govt. Boys Hr. Sec. School,
Nattrampalli, Tirupattur District.

B. Prabakaran

Vocational Teacher,
Govt. Boys Hr. Sec. School,
Vandavasi, Thiruvannamalai District.

N. Palanivelu

Vocational Teacher,
Govt. Boys Hr. Sec. School,
Arni, Thiruvannamalai District.

R. Arumugam

Vocational Teacher,
Govt. Boys Hr. Sec. School,
Ondipudur, Coimbatore District.

A. Maduraimuthu

Vocational Teacher,
Govt. Boys Hr. Sec. School,
Magudanchavadi,
Salem District.

EMIS Technology Team

R.M. Sathesh

State Coordinator Technical,
TN EMIS, Samagra Shiksha.

K.P. Sathya Narayana

IT Consultant,
TN EMIS, Samagra Shikaha

R. Arun Maruthi Selvan

Technical Project Consultant,
TN EMIS, Samagra Shiksha

This book has been printed on 80 G.S.M.
Elegant Maplitho paper.

Printed by offset at:

NOTES

NOTES